

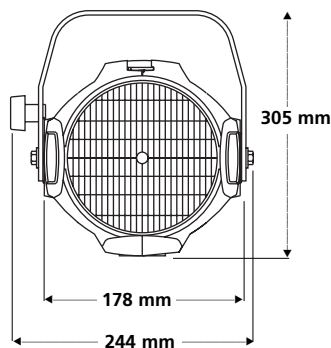

## Specifications

### Wash luminaire

- |   |  |
|---|--|
| <p><b>Physical</b></p> <ul style="list-style-type: none"><li>• Die-cast aluminium construction</li><li>• Tool free cleaning of the reflector and lens</li><li>• Thermally insulated knobs</li><li>• Sealed reflector housing</li><li>• Reflector temperature control through integral heat sink fins</li><li>• Integral die cast colour frame / accessory holders and top mounted retainer</li><li>• Positive locking yoke clutch</li></ul> <p><b>Electrical</b></p> <ul style="list-style-type: none"><li>• 230-240V, 50Hz</li><li>• High temperature 3-conductor cable in a silicon rubber outer sleeve</li><li>• CE approved</li></ul> <p><b>Lamp</b></p> <ul style="list-style-type: none"><li>• EA PAR — 750W maximum</li><li>• MCM PAR — 575W maximum</li><li>• HPL — compact tungsten filament lamp</li><li>• Patented filament geometry makes for extremely efficient light collection and transmission</li><li>• Integral die-cast aluminium heat sink lamp base</li></ul> | <p><b>Lenses</b></p> <ul style="list-style-type: none"><li>• Four heat resistant, moulded borosilicate glass lenses supplied with each unit: Very Narrow Spot (VNSP), Narrow Spot (NSP), Medium Flood (MFL) and Wide Flood (WFL).</li><li>• Tool free lens changing</li><li>• Thermally insulated lens rotation ring outside of the luminaire</li></ul> <p><b>Optical</b></p> <ul style="list-style-type: none"><li>• EA - Modified parabolic and multifaceted reflector</li><li>• Computer designed reflector facets moulded into heat sink casting, finished with an enhanced aluminium (EA) deposition process</li><li>• MCM - Faceted borosilicate reflector with dichroic coating</li></ul> |
|---|--|

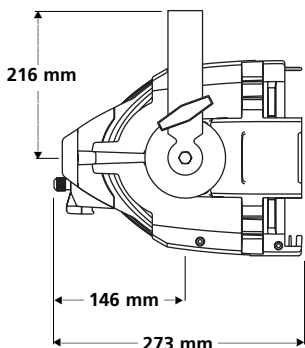

Source Four PAR EA and MCM Weights\*

	Luminaire Weight kg	Packed Weight kg	Packed Dimensions mm
PAR EA & MCM	3.0	5.0	280 x 280 x 410

\*Weights and dimensions approximate

Lamp code	Watts	Volts	Initial Lumens	Colour Temp.	Average Rated Life (hours)	MF
HPL 750/230	750	230	19,400	3,200°	300	0.90
HPL 750/240	750	240	19,400	3,200°	300	0.90
HPL 575/230	575	230	14,900	3,200°	400	0.76
HPL 575/240	575	240	14,900	3,200°	400	0.76
HPL 575/230X	575	230	11,780	3,050°	1500	0.61
HPL 575/240X	575	240	11,780	3,050°	1500	0.64
HPL 375/230X	375	230	7,800	3,050°	1000	0.38
HPL 375/240X	375	240	7,800	3,050°	1000	0.38

**Warning:** Use of lamps other than HPL will void CE safety approval and product warranty. Source Four PAR EA is rated for 750W maximum. Source Four PAR MCM is rated for 575W maximum.

**Note:** For illumination with any lamp, multiply the candlepower of a beam spread by the Multiplying Factor (MF) shown for that lamp.

All photometric data in this document was prepared using standard production luminaires, and the Prometric™ measurement system. Luminaires were adjusted for cosine distribution, and were tested with calibrated HPL 750/230V 19,400 and HPL 750/240V 19,400 lumens lamps (EA) and HPL 575/230 14,900 and HPL 575/240 14,900 lumens lamps at their rated voltage. All data were normalised to nominal lamp lumens.

To determine illumination in footcandles or lux at any throw distance, divide candlepower by distance squared.

EA Very Narrow Spot (VNSP)

Distance (m)	11.0	15.0	20.0	24.0
Field Diameter (m)	3.0	4.2	4.8	6.0
Illumination 230V (lux)	1904	971	744	476
Illumination 240V (lux)	2223	1196	673	467

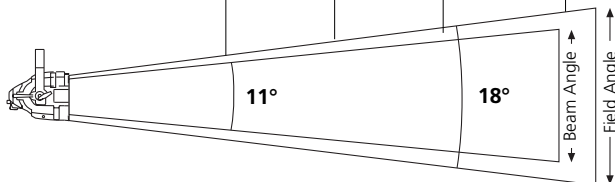

For Field diameter at any distance, multiply distance by 0.32  
For Beam diameter at any distance, multiply distance by 0.19

W/V	Candlepower	Field Lumens	Efficacy LPW	Efficiency %
750/230	282000	9,270	12.4	47.8
750/240	269,000	5,270	7.0	27.2

MCM Very Narrow Spot (VSNP)

Distance (m)	11.0	15.0	20.0	24.0
Field Diameter (m)	3.0	4.2	4.8	6.0
Illumination 230V (lux)	1446	778	438	304
Illumination 240V (lux)	1364	733	413	286

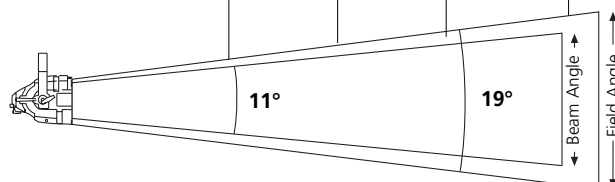

For Field diameter at any distance, multiply distance by 0.31  
For Beam diameter at any distance, multiply distance by 0.17

W/V	Candlepower	Field Lumens	Efficacy LPW	Efficiency %
575/230	175,000	6,610	11.5	44.4
575/240	165,000	6,430	11.2	43.2

# Source Four™ PAR EA and MCM

## EA Narrow Spot (NSP)

Distance (m)	11.0	15.0	20.0	24.0
Field Diameter (m)	3.0	4.2	4.8	6.0
Illumination 230V (lux)	1904	971	744	476
Illumination 240V (lux)	2132	1147	645	448

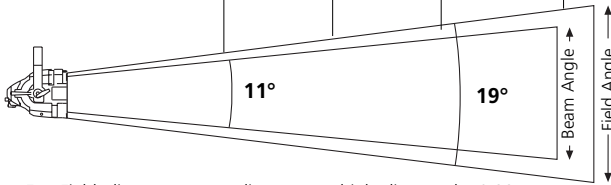

For Field diameter at any distance, multiply distance by 0.33  
For Beam diameter at any distance, multiply distance by 0.19

W/V	Candlepower	Field Lumens	Efficacy LPW	Efficiency %
750/230	270,000	9,250	12.3	47.7
750/240	258,000	5,270	7.0	27.2

## MCM Narrow Spot (NSP)

Distance (m)	11.0	15.0	20.0	24.0
Field Diameter (m)	3.0	4.2	4.8	6.0
Illumination 230V (lux)	1174	631	355	247
Illumination 240V (lux)	1099	591	333	231

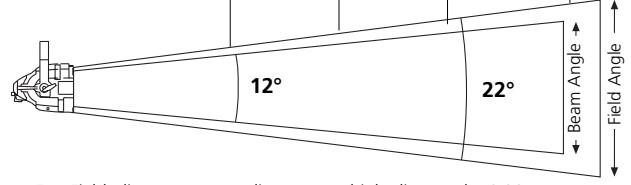

For Field diameter at any distance, multiply distance by 0.33  
For Beam diameter at any distance, multiply distance by 0.17

W/V	Candlepower	Field Lumens	Efficacy LPW	Efficiency %
575/230	142,000	6,450	11.2	43.3
575/240	133,000	6,450	11.2	43.3

## EA Medium Flood (MFL)

Distance (m)	8.0	11	14	17
Field Diameter (m)	3.0	4.2	4.8	6.0
Illumination 230V (lux)	1904	971	744	476
Illumination 240V (lux)	1828	967	597	405

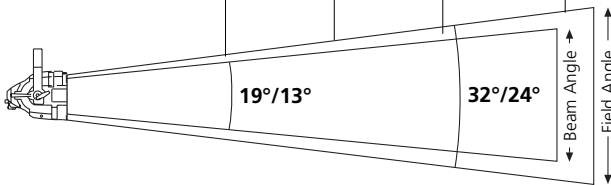

For Field diameter at any distance, multiply distance by 0.57/0.41  
For Beam diameter at any distance, multiply distance by 0.33/0.23

W/V	Candlepower	Field Lumens	Efficacy LPW	Efficiency %
750/230	127,000	9,370	12.5	48.3
750/240	117,000	5,270	7.0	27.2

## MCM Medium Flood (MFL)

Distance (m)	8.0	11.0	14.0	17.0
Field Diameter (m)	3.0	4.2	4.8	6.0
Illumination 230V (lux)	1158	612	378	256
Illumination 240V (lux)	1183	626	386	262

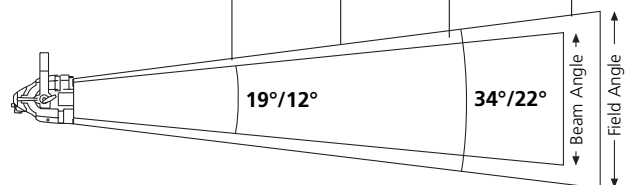

For Field diameter at any distance, multiply distance by 0.55/0.39  
For Beam diameter at any distance, multiply distance by 0.41/0.21

W/V	Candlepower	Field Lumens	Efficacy LPW	Efficiency %
575/230	74,100	5,390	9.4	36.2
575/240	75,700	5,910	10.3	39.7

## EA Wide Flood (WFL)

Distance (m)	6.0	8.0	9.0	11.0
Field Diameter (m)	3.0	4.2	4.8	6.0
Illumination 230V (lux)	1904	971	744	476
Illumination 240V (lux)	1578	888	701	469

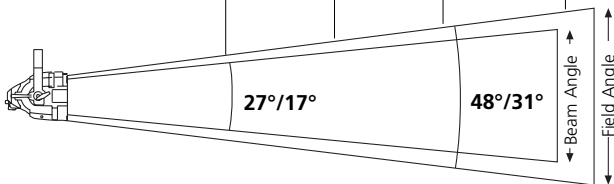

For Field diameter at any distance, multiply distance by 0.89/0.56  
For Beam diameter at any distance, multiply distance by 0.47/0.30

W/V	Candlepower	Field Lumens	Efficacy LPW	Efficiency %
750/230	59,100	8,520	11.4	43.9
750/240	56,800	5,270	7.0	27.2

## MCM Wide Flood (WFL)

Distance (m)	6.0	8.0	9.0	11.0
Field Diameter (m)	3.0	4.2	4.8	6.0
Illumination 230V (lux)	986	555	438	293
Illumination 240V (lux)	914	514	406	272

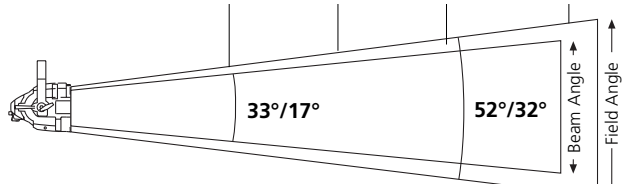

For Field diameter at any distance, multiply distance by 0.87/0.57  
For Beam diameter at any distance, multiply distance by 0.48/0.30

W/V	Candlepower	Field Lumens	Efficacy LPW	Efficiency %
575/230	35,500	6,730	11.7	45.2
575/240	32,900	6,530	11.4	43.8

## Ordering information

### Source Four PAR EA 750W luminaire

Part No	Description
7061A1206-0X	Source Four PAR EA (Black)
7061A1206-1X	Source Four PAR EA (White)

### Source Four PAR MCM 575W luminaire

Part No	Description
7061A1226-0X	Source Four PAR MCM (Black)
7061A1226-1X	Source Four PAR MCM (White)

ETC Source Four PAR EA & MCM luminaires are supplied with 4 lens set: VNSP, NSP, MFL, WFL; colour frame and cable to bare ends as standard

### Source Four PAR and MCM Accessories

Part No	Description
PSF1019	Barn door
7060A1022	Safety cable 800mm
7060A1020	Colour frame 190 x 190mm (included)
7061A4002	Very Narrow Spot lens
7061A4003	Narrow Spot lens
7061A4005	Medium Flood lens
7061A4006	Wide Flood lens
7061A1013	Set of four Source Four PAR lenses (VNSP, NSP, MFL, WFL)
PSF1027	Half hat 190 x 190 x 152mm
PSF1031	Concentric louvre 190 x 190 x 51mm
PSF1030	Colour extender short 190 x 190 x 76 mm
PSF1029	Colour extender long 190 x 190 x 152 mm
PSF1028	Honeycomb louvre 190 x 190 x 13mm

**Note:** For colours other than black or white and for the full range of Source Four accessories available please contact ETC Europe or your local dealer



**Europe** Tel: +44 (0)20 8896 1000 • Fax: +44 (0)20 8896 2000  
**Americas** Tel: +1 608 831 4116 • Fax: +1 608 836 1736  
**Asia** Tel: +852 2799 1220 • Fax: +852 2799 9325  
**Email:** mail@etceurope.com • **Web:** www.etcconnect.com



7061L1003-GB - rev B