

# SENSOR<sup>®</sup>3



---

## Sensor Portable Pack (SP Series) CEM to CEM3 Retrofit Manual

Revision C

Copyright © Electronic Theatre Controls, Inc.  
All Rights reserved.  
Product information and specifications subject to change.  
Part Number: **7142M2310** Rev C  
Released: 2016-02

ETC permits the reproduction of materials in this manual only for non-commercial purposes. All other rights are reserved by ETC.

ETC<sup>®</sup>, and Sensor<sup>®</sup> are registered trademarks of Electronic Theatre Controls, Inc. in the United States and other countries.

All other trademarks, both marked and not marked, are the property of their respective owners.

# Introduction

---

This manual is intended to guide ETC Service Technicians through the process of upgrading existing Sensor<sup>®</sup> Portable Packs to Sensor3 Portable Packs with a CEM3 control module. This manual covers SP12 and SP24 portable packs.

## Contacting Technical Services

If you have questions about the retrofit process that are not answered in this manual, please contact ETC Technical Services.

### Americas

ETC International  
Technical Services Department  
3031 Pleasant View Road  
Middleton, WI 53562

+1 800 775 4382

+1 608 831 4116

service@etcconnect.com

Please email comments about this manual to: [TechComm@etcconnect.com](mailto:TechComm@etcconnect.com)

## Warnings and Notice Conventions

These symbols are used in Sensor documentation to alert you to danger or important information:



---

**Note:** *Notes are helpful hints and information that is supplemental to the main text.*

---



---

**CAUTION:** *A Caution statement indicates situations where there may be undefined or unwanted consequences of an action, potential for data loss or an equipment problem.*

---



---

**WARNING:** *A Warning statement indicates situations where damage may occur, people may be harmed, or there are serious or dangerous consequences of an action.*

---



---

**WARNING:** *RISK OF ELECTRIC SHOCK! This warning statement indicates situations where there is a risk of electric shock.*

---

## Other Retrofit Kits

This retrofit kit is for upgrading a Sensor CEM portable pack to a CEM3 portable pack. Other kits are available for retrofitting other Sensor and Sensor+ dimming products.

Available retrofit kits include:

- Sensor SP12 Portable Pack CEM3 Retrofit Kit - ETC Part # 7142K1001
- Sensor SP24 Portable Pack CEM3 Retrofit Kit - ETC Part # 7142K1002
- Sensor+ SP12+ Portable Pack CEM3 Retrofit Kit - ETC Part # 7142K1003
- Sensor+ SP24+ Portable Pack CEM3 Retrofit Kit - ETC Part # 7142K1004
- Sensor Installation Rack CEM3 Retrofit Kit - ETC Part # 7141K1001
- Sensor+ Installation Rack CEM3 Retrofit Kit - ETC Part # 7141K1101
- Sensor SP48 Touring Rack CEM3 Retrofit Kit - ETC Part # 7143K1001
- Sensor SP96 Touring Rack CEM3 Retrofit Kit - ETC Part # 7143K1002
- Sensor+ Touring Rack Universal CEM3 Retrofit Kit - ETC Part # 7143K1005

## Safety

Please note the following safety warnings before use:

- Disconnect power from the packs before all maintenance.



**WARNING:** *Dimmer racks without an accessible power disconnect device cannot be serviced safely. Before removing dimmer or control modules for service, de-energize main feed to dimmer rack and follow appropriate Lockout/Tagout procedures as described in NFPA Standard 70E. It is important to note that electrical equipment such as dimmer racks can present an arc flash safety hazard if improperly serviced. This is due to available large short circuit currents on the feeders of the equipment. Any work on energized equipment must comply with OSHA Electrical Safe Working Practices.*

---

## Overview of this Manual

Reference this manual throughout the retrofit procedure.

- [Preparation \(page 7\)](#) - emptying the pack and removing the external components
- [Remove the CEM Backplane \(page 8\)](#) - remove the existing backplane from the pack
- [Replace Phase A Bus Bar \(page 9\)](#) - remove the old bus bar and install a new one
- [Attach New Power Harness \(page 10\)](#) - install and secure the power wire harness adapter
- [Install CEM3 Backplane \(page 10\)](#) - install the new backplane and connect and secure the data cabling
- [Convert Dimmer Output Cable \(page 12\)](#) - install the adapter card for the new dimmer output connector
- [Add Connections to the Backplane \(page 12\)](#) - connect the power and data connectors to the new backplane
- [Replace AF Cards \(AF Packs Only\) \(page 14\)](#) - remove the existing Advanced Feature cards and install the new ones
- [Install New Pack Lid and Reassemble Pack \(page 14\)](#) - install the new pack lid and reassemble the external components

When viewing this document in electronic form (.PDF file) with Adobe Acrobat Reader, blue italicized text followed by a page number such as "[Overview of this Manual, page 3](#)" is a link within the document. By clicking on the link, you can jump to that section or topic.





# Section 1

## Unpack and Organize

The table below lists the parts and components needed to retrofit a Sensor portable pack (SP12 or SP24) to become a Sensor3 pack with a CEM3. Each part is listed to reflect the different quantities for the different kits and types of packs.

	Parts/Components ETC Part Number	SP12 Kit 7142K1001	SP24 Kit 7142K1002
Parts Included in the Kits	Phase Connector Top/Bottom 7052A3015	1	0
	Phase Connector Top/Bottom 7052A3081	0	1
	CEM Classic to CEM3 Backplane Power Adapter Harness 7141B7010	1	1
	Sensor3 Pack Top Cover Assembly 7142A2005	1	1
	Sensor3 Pack Backplane Assembly 7142A2006-CFG	1	1
	Sensor Portable Pack CEM Classic to CEM3 Retrofit Manual 7142M2310	1	1
	16 pin power transition PCB 7150B4009A	1	1
	Dimmer Output Lower Ribbon Card LF Assembly 7150B5606	1	1
	Backplane DMX PCB Cable 7152B8001	1	1
	Screw 6-32 x .250 - PhPHMS SEMS HW213	2	2
	Screw 8-32 X 3/8 Ph PH MS CP W/Patch HW377	3	3
	Cable tie 4" Hi-temp Black HW7121	28	28
	Ribbon Cable Clamp 1X1 White HW726	4	4
	CEM+ Backplane 1/8" #8 screw spacer HW9343	3	3
	Tie-mount (sticky-back) HW741	8	8
	Terminal Ring #6 18-14 GA BLU J434	2	2
	Heat Shrink 1 1/2" Black W682	2	2

	Parts/Components ETC Part Number	SP12	SP24
Additional Line Items	Sensor3 AF Card (Optional) 7150B5623	1	1
	SP6 Door 7142A2001	1	0
	SP12 Door 7142A2003	0	1
	CEM3 7140A1000	1	1

Required Tools
#1 Phillips screwdriver
#2 Phillips screwdriver
3/8" socket
7/16" socket
5/32" Allen wrench
7/16" wrench
3/8" wrench
Heat gun
Diagonal wire cutter
Permanent marker
Crimp tool for ring terminal splice (T&B ERG2001 or WT-112M hand tool)
Wire strippers



# Section 2

## The Retrofit

---

### Preparation

- Step 1: Use Sensor Configuration Editor and a SLTA to download and save the current Sensor configuration out of the pack for later reference. For information on this process contact ETC Technical Services (see [page 1](#)).
- Step 2: Disconnect all of the Cam-Lok® connectors and data connections from the portable pack.
- Step 3: Remove the dimmer modules from the pack. Note and document the modules' order/positioning in the pack for proper insertion and configuration later.
- Step 4: Use a digital voltmeter and VERIFY that power is off by checking voltages for all combinations between the phase bars, neutral and ground.
- Step 5: Remove the CEM from the pack.
- Step 6: Remove the pack door using a #2 Phillips-head screwdriver.

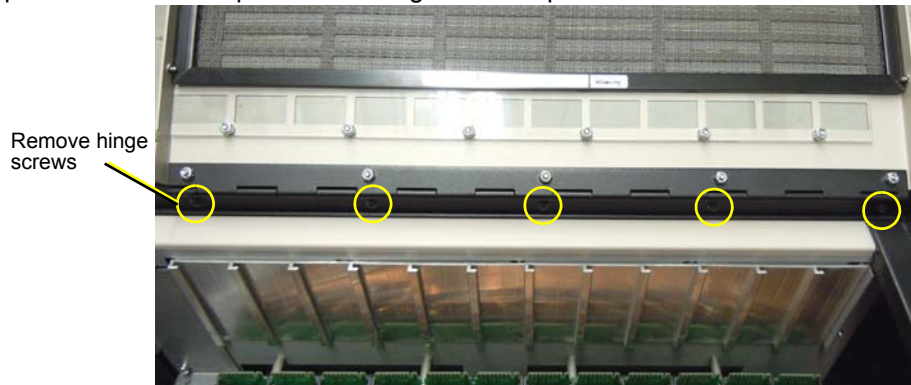

- Step 7: Remove the four black side covers. They are held in place by 24 5/32" allen screws (three on each corner of the pack, on both the top and bottom).

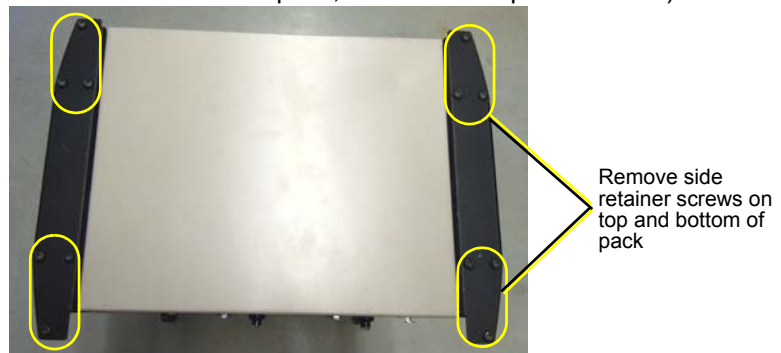

### **Note:**

*If your pack has the Cam-Lok pass thru option, the side panels are secured at the bottom with extra long hex head bolts. These are in place of the bottom allen screws and require a 7/16" socket to remove.*

---

## Remove the CEM Backplane

- Step 1: Remove the lid retaining bolts using a wrench (may be 7/16" or 3/8" depending on your pack model). The bolts are found at the top of each side of the pack, just beneath the lip of the carrying handles.

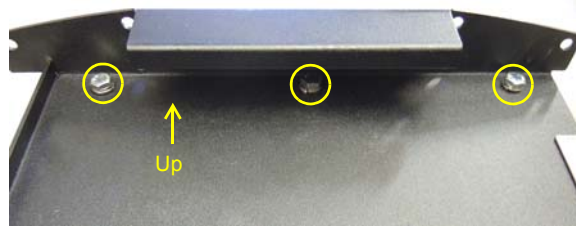

Side View of Pack

- Step 2: Raise the lid from the data connection side to expose the CEM backplane metal.
- Step 3: Disconnect the DMX ribbon cable and the analog data cable from the backplane using a #2 Phillips screwdriver. You will have to back the connectors out of the backplane metal to free them.
- Step 4: Remove the lid entirely to expose the inner cavity of the pack.
- Step 5: Disconnect the power connector and dimmer output cable from the backplane using a #2 Phillips screwdriver. Use caution when backing the connectors out of the metal to prevent damaging the cables' outer jacketing.



**CAUTION:** *Be careful not to damage the outer jacket of the power or dimmer output wires when removing them from the backplane metal. If you damage the jacketing, contact ETC Technical Services before proceeding with the procedure.*



**Note:** *Check to see if the power connector is damaged or disfigured from previous use. If so, it will need to be replaced. Contact ETC technical Services (see [page 1](#)) for replacement parts and instructions. Damage to this connector is typically in the form of a crack in the left or right side of the plastic housing of the power connector. Presence of a crack can cause intermittent rebooting and power loss to the control electronics*

Disconnect these from Backplane

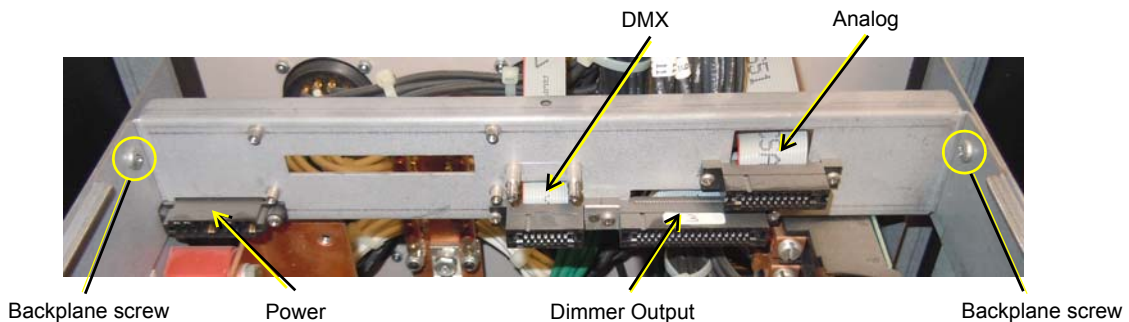

- Step 6: Remove the backplane screws found at the top corners on each side of the backplane using a #2 Phillips screwdriver.
- Step 7: Bend in the side arms of the backplane and remove the CEM backplane from the pack.

## Replace Phase A Bus Bar

A slightly modified Phase A bus bar is included in the upgrade kit. This new bus bar allows for greater clearance between the bus bar and the CEM3 backplane. You will need to remove the old Phase A bus bar and install the new one in its place.

### To remove the old bus bar:

Step 1: Disconnect the Phase A Cam Wire and Phase A Detection Wire using a #2 Phillips screwdriver or socket (may be 7/16" or 3/8" depending on your pack model) as required. Save the hardware for these connections as you will need to reuse them.



Remove these fasteners

### **Note:**

*If your pack is set up for single-phase operation, you will have to remove the screw that holds the phase jumper bar to the Phase A bus bar. Save the screw as you will need it to reattach to the new bus bar.*

Step 2: Using a socket (may be 7/16" or 3/8" depending on your pack model), disconnect the two hex bolts holding the bus bar to the pack.

Step 3: Remove the old bus bar from the pack.

### To install the new bus bar:

Step 4: Place the new phase bar in its intended location and secure it with the bolts removed earlier. The new phase bar has a distinctive notch in the copper at the top corner bend of the bar. Tighten the bolts to 6 ft.-lbs.

Notch in new phase bar



Step 5: Attach the Phase A Cam Wire to the phase bar.

Step 6: Attach the phase detection wire to the bus bar. The phase detection wire must be installed in the orientation shown at right to meet minimum spacing requirements for the Phase B bus bar.

Phase detection wire must be in this orientation

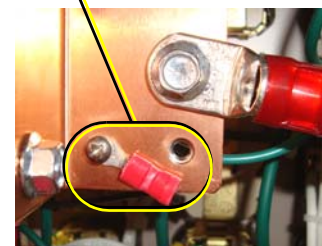

### **Note:**

*If your pack was set up for single-phase operation, you will have to reconnect the phase jumper bar to the phase A bus bar using the previously removed screw.*

## Attach New Power Harness

The upgrade kit contains an edge connector (straight thru PCB) and a power wire harness adapter to transition power to the new power connector.

- Step 1: Insert the edge connector (straight thru PCB) into the old backplane power connector. The connector is the same on both sides and top and bottom.
- Step 2: Install the power adapter harness to the edge connector (straight thru PCB) to old power connector (match the wire colors)

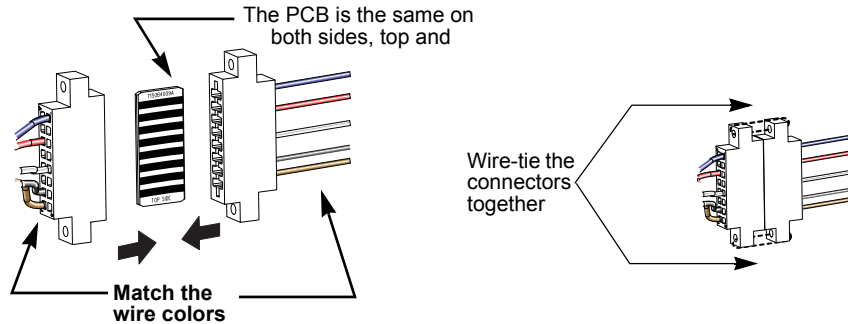

- Step 3: Secure the power connectors together with provided 4"-wire-ties. Try to align the wire tie stub behind the flat edge of the connector. This will ease the installation of the heat shrink. Clip the wire tie ends for neatness.
- Step 4: Slide the large heat shrink tube onto the power harness and slide it back until it covers the newly completed connector and edge card assembly. A spare heat shrink is also provided in the kit.
- Step 5: Carefully heat the shrink tube with a heat gun or other heat source until it protects and secures the connector assembly.



Leave the green ground wire running out of the pack; you will connect it to the CEM3 backplane in a later step.

## Install CEM3 Backplane

- Step 1: Bend one arm of the backplane metal in towards the opposite arm (about 30 deg). Bend the metal as little as possible to get it inside the pack.
- Step 2: Insert the backplane metal at an angle. Then straighten it once it is past the face of the pack.

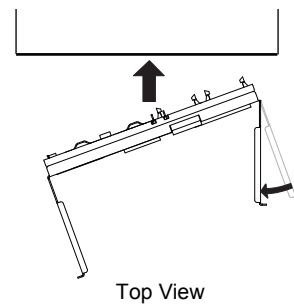

Step 3: Once in place, insert the clips on the arms into their respective locations in the pack metal and then slide the backplane forward so that the clips stay in place. The backplane is far enough forward when the screw holes in the upper corners are visibility *not insert the screws yet as you may need to partially remove the backplane in a later step*



Slide arm clips in place to ensure proper screw alignment

### Grounding the power harness

On the rear of the backplane, you will find an open screw hole near the bottom of the metal, between the CAT5 connector and the blue DMX connector. This is the intended location for landing the green ground wire from the power wire harness adapter.

- Cut the power wire harness adapter's ground wire to an appropriate length (approx. 8") to connect to the open screw hole. Strip 1/2" of the 18 gauge wire jacketing to expose bare wire for the next step.
- Connect the provided ring crimp connector (ETC Part# J434) to the bare end of the ground wire using a T&B ERG2001 or WT112M hand tool.
- Secure the ring connector to the backplane using the 6-32 x 1/4" screw with lock washer (ETC part # HW213) from the upgrade kit. It may be necessary to raise the backplane out of its location in order to tighten the screw.

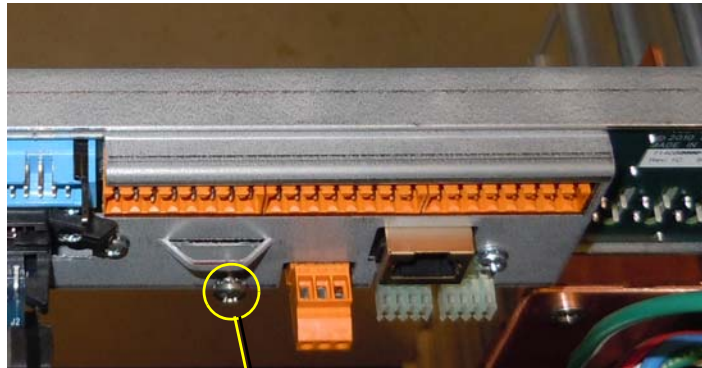

Connect ground wire to this location using screw and washer from kit

- Step 4: Secure the backplane in place using the new screws and collars provided in the kit. Screw holes are in the top corners of each arm of the backplane.

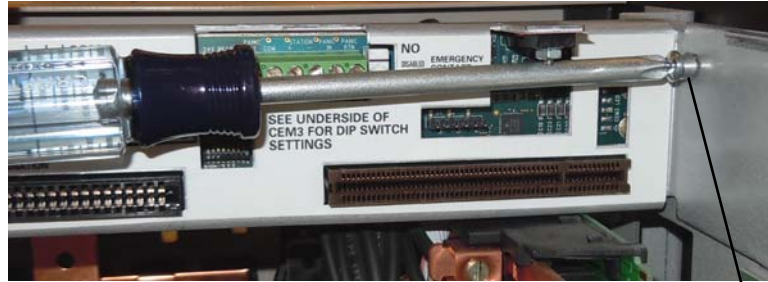

Be sure to use collars

## Convert Dimmer Output Cable

The upgrade kit includes a transition card to adapt the old dimmer output connector to the new backplane connectors. This card is labeled as a “LOWER CARD” indicating the lower connector slot that it will connect to.

- Step 1: Install the transition card into the old dimmer output cable connector. Align the transition card and ribbon cable so that the red-striped wire of the ribbon cable lines up with pin-1 on the card. Pin-1 is indicated by a downward arrow on the J2 side of the connector (see below). Make sure the card is fully seated in the old connector.

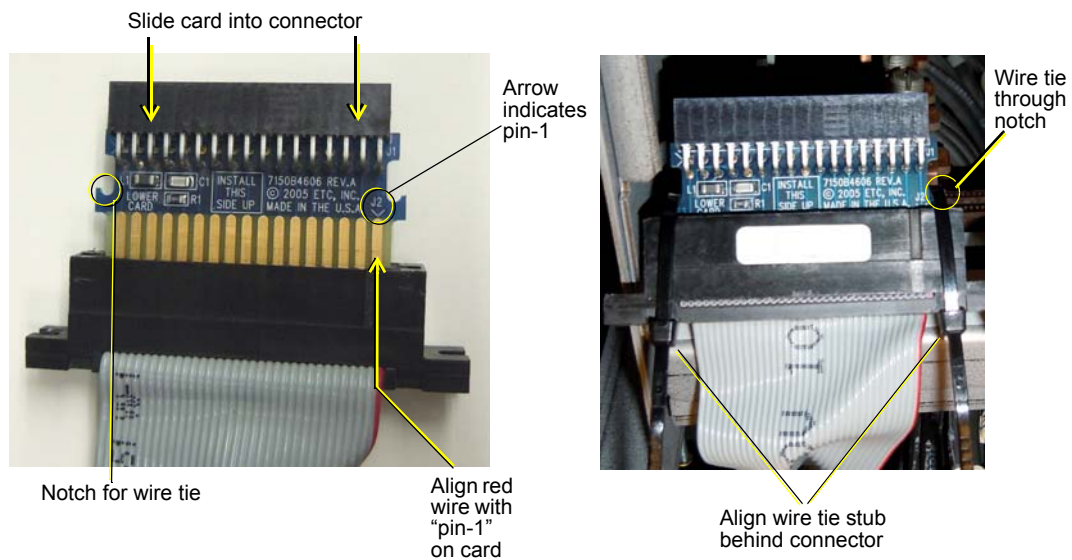

- Step 2: Secure the transition card in the connector using two 4” wire ties. There is a notch on the left and right sides of the card for the wire ties to rest in. Try to align the wire tie stub behind the flat edge of the connector.

- Step 3: Trim the ends of the wire ties for neatness.

## Add Connections to the Backplane

- Step 4: Connect the power wire harness adapter to the power connector on the rear of the backplane. The connector is keyed and will only connect one way.
- Step 5: Bundle any excess wires from the power harness adapter together and secure them with a wire tie.
- Step 6: Trim the end of the wire tie and tuck the bundle into the vacant punch out in the side of the pack support frame.

Step 7: Connect the dimmer output cable to the appropriate connector on the rear of the backplane. For portable packs, use the lower connector, closest to the center of the backplane. Make sure the “INSTALL THIS SIDE UP” label on the transition card is visible from above.

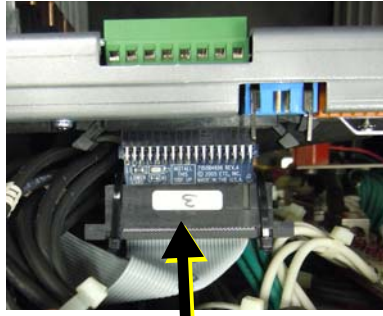

Dimmer Output Cable

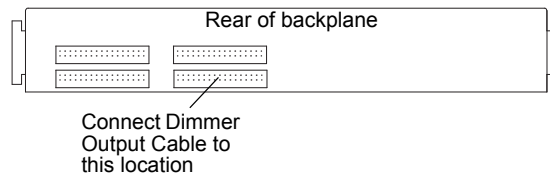

## Backplane Settings

Upgrade kit backplanes ship from the factory with all DIP switches in the off (down) position. You will have to set the DIP switches on the new backplane to match your pack. You will also have to verify the termination switch settings.

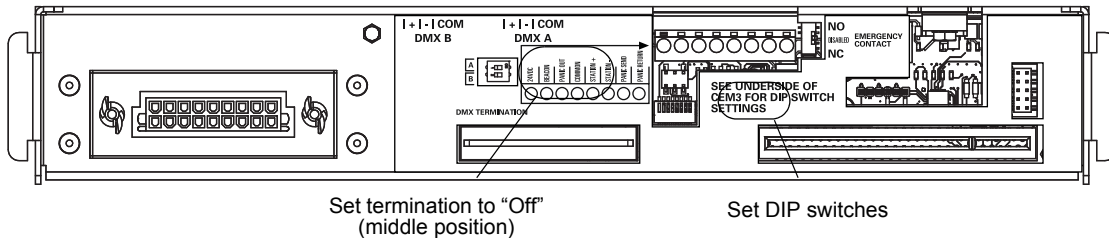

Set termination to “Off”  
(middle position)

Set DIP switches

- a. Set both termination switches to “Off” (middle position).
- b. Using a precision screwdriver, set the DIP switches to match your pack type according to:
  - number of dimmer module slots (6 or 12)
  - whether the pack has Advanced Features (AF)

Use the following chart to determine your required DIP switch settings:

Pack Model	DIP switch Number							
	1	2	3	4	5	6	7	8
SP12 (6 slots)							On	On
SP12 AF (6 slots)		On					On	On
SP24 (12 slots)							On	
SP24 AF (12 slots)		On					On	

“On” position = switch pushed to the top

## Replace AF Cards (AF Packs Only)

If your pack supports Advanced Features (AF) you will need to replace the AF card as well. If you identified your pack as AF when ordering, a new AF card should have been sent with your upgrade kit. If you do not have the new AF card, you may continue with the retrofit and you can add AF cards at a later date without having to disassemble the pack. While the pack is opened, however, it is a good time to easily swap out the cards.

AF cards are located on the right side of the dimmer module slot between the copper neutral busses and the dimming circuitry cards.

### To replace the AF cards:

- Step 1: Remove the old AF card by flipping the white retainer tab on the card into the down position.
- Step 2: Pull the old card out of the slot.
- Step 3: Verify that all DIP switches on the new card are in the "off" (down) position. This designates the card as address #1.
- Step 4: Slide the new AF card completely into the vacant slot.
- Step 5: Flip the white tab up to lock the new card in place.

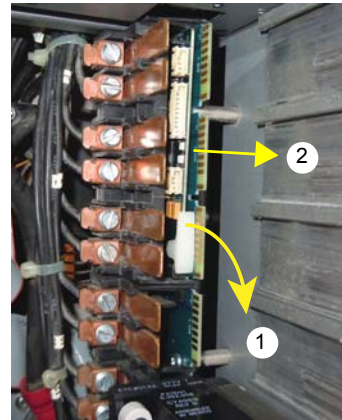

Flip tab down, pull card out

## Install New Pack Lid and Reassemble Pack

A new pack lid with the appropriate beacon board and Sensor3 sticker is included in the kit

- Step 6: Place the new Sensor3 pack lid partially in place and in the upright position over the output connector side of the pack.
- Step 7: Connect the new DMX ribbon cable to the blue connector on the rear of the backplane and to the DMX connector on the beacon board in the pack lid.
- Step 8: Connect the CAT 5 cable to the RJ-45 port on the rear of the backplane and to the RJ-45 connector on the beacon board in the pack lid.



- Step 9: Peel the backing off of the provided plastic wire retainer clip and stick it to the center of the underside of the pack lid. Slide the DMX cable and the CAT5 cable into the retainer clip...

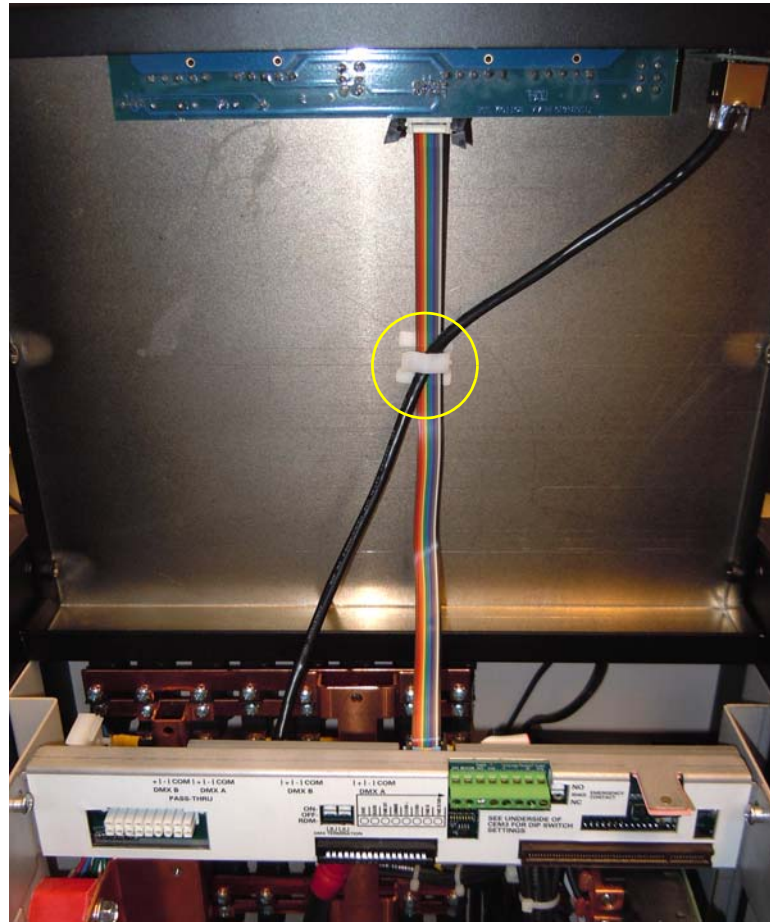

- Step 10: Lower the pack lid into place in a closed position.
- Step 11: Secure the pack lid in place using the bolts and washers removed earlier. Use three bolts and washers per side (6 total).

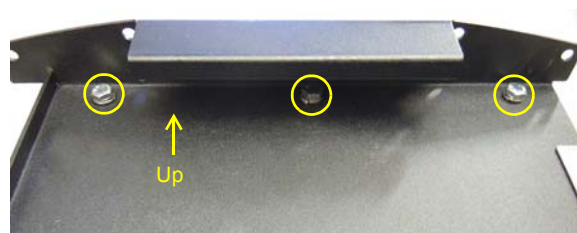

Side View of Pack

Step 12: Place the pack side rails back into their original locations and secure them with the 5/32" allen screws removed earlier. three screws top and bottom, for each side rail (24 screws total). *Be sure to put the side rail with the door hinge screw holes in the appropriate location, opposite the door latch retainer.*



Place side rail with door hinge screw holes in this location.

Door latch retainer

Step 13: Attach the new door to the side rail using the screws removed earlier.

Replace hinge screws

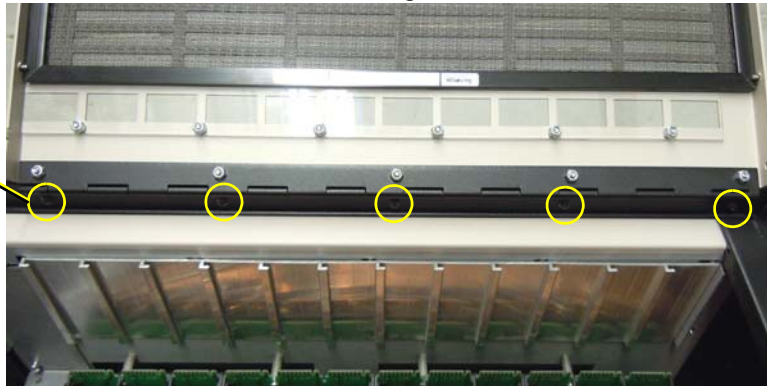

Step 14: Replace the dimmer modules to their appropriate locations

Step 15: Insert the new CEM3 control module into the control module slot.

Step 16: Connect power to the pack.

Step 17: Power up the control module and configure it according to the *CEM3 Configuration Quick Guide* that accompanied the module in the upgrade kit.





**Corporate Headquarters** ■ 3031 Pleasant View Road, P.O. Box 620979, Middleton, Wisconsin 53562-0979 USA ■ Tel +608 831 4116 ■ Fax +608 836 1736

**London, UK** ■ Unit 26-28, Victoria Industrial Estate, Victoria Road, London W3 6UU, UK ■ Tel +44 (0)20 8896 1000 ■ Fax +44 (0)20 8896 2000

**Rome, IT** ■ Via Pieve Torina, 48, 00156 Rome, Italy ■ Tel +39 (06) 32 111 683 ■ Fax +44 (0) 20 8752 8486

**Holzkirchen, DE** ■ Ohmstrasse 3, 83607 Holzkirchen, Germany ■ Tel +49 (80 24) 47 00-0 ■ Fax +49 (80 24) 47 00-3 00

**Hong Kong** ■ Rm 1801, 18/F, Tower 1 Phase 1, Enterprise Square, 9 Sheung Yuet Road, Kowloon Bay, Kowloon, Hong Kong ■ Tel +852 2799 1220 ■ Fax +852 2799 9325

**Service:** (Americas) [service@etconnect.com](mailto:service@etconnect.com) ■ (UK) [service@etceurope.com](mailto:service@etceurope.com) ■ (DE) [techserv-hoki@etconnect.com](mailto:techserv-hoki@etconnect.com) ■ (Asia) [service@etcasia.com](mailto:service@etcasia.com)

**Web:** [www.etconnect.com](http://www.etconnect.com) ■ Copyright © 2016 ETC. All Rights Reserved. ■ Product information and specifications subject to change.

7142M2310 ■ Rev C ■ Released 2016-02