

ETC ARCHITECTURAL

ER & DR Dimming Rack

Unison™ Lighting Control System

Owner's Manual

UNISON

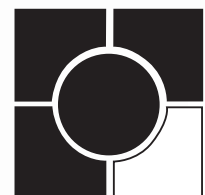

Contents

- Introduction**
 - Warning and notice conventions 3
 - Important notes 3
- System configuration**
 - To access configuration menus 5
 - To initialize a dimming rack 5
 - To detail dimming circuits..... 6
 - To enter Dimmer Doubling (DD) settings 7
 - To set dimmer levels in the Test submenu 8
 - To set dimmer levels in the Set All submenu 8
 - To set the Backup look 9
- Configuring the Architectural Processor**
 - To load a Unison Light Manager configuration in to the control processor..... 11
 - To bind control stations to the architectural processor 12
 - To unbind control stations (optional) 13
 - To enter the Date and Time local control settings 14
 - To enter your location settings 15
 - Working in the Setup menu 16
 - Working in the Diagnostics menu..... 19
 - To save the installed configuration 20
- Maintaining Your Unison System**
 - Cleaning dimming rack air filters 21
- Appendix A: Frequently Asked Questions** 23
- Appendix B: Error Message Chart** 27
- Appendix C: Wall Station ID Chart** 29
- Appendix D: Rack Configuration Chart** 31
- Appendix E: Architectural Menu Flow Chart** 33
- Appendix F: Dimmer Menu Flow Chart** 35
- Appendix G: U.S. Time Zone and Location Map** 37

Introduction

Warning and notice conventions

Throughout this guide, these symbols are used to indicate warning, caution and points of interest.



Note

Calls your attention to important additional information.



Warning

Alerts you to dangers that could cause serious injury or death to you or those working with you.



Caution

Alerts you to dangers that could damage the equipment.

Important Notes



Warning: Risk of electrical shock.

This equipment should be installed and wired by a qualified electrician. Always follow applicable building and electrical codes when installing this equipment. If you are not sure if your installation complies with local or national codes, contact your local building inspector. Service by qualified personnel only.

System configuration

Unison rack dimming software version 2.0

To access configuration menus

1. Press the concealed menu activate button for three seconds. Menu screen will appear. See *Figure 1* for concealed button.
2. Press [up arrow] or [down arrow] to scroll through bracketed options.
3. Press [Enter] to move bracket placement to the right.
4. Press [Exit] to move bracket placement left.

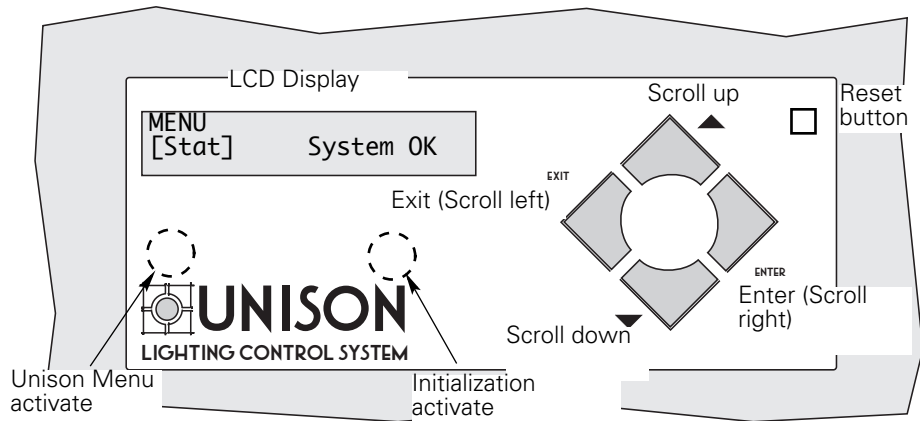

Figure 1: Control module interface for the Dimmer Menu

To reset a Control Module

When the rack door is open, a Reset button is available in the top right corner. Pressing it restarts the Control Module using saved settings. Resetting will temporarily interrupt all Control Module processing. Lights will flash momentarily or may go out while system boots.

To initialize a dimming rack

Initialization refers to the programming of rack voltage, size and DMX start address. The first time you access menus on a Unison dimming rack, you must initialize the dimming system processor.

1. Complete Rack Configuration Chart (Appendix D) on page 31.
2. Press the concealed "Initialization activate" button for three seconds. The **[Stat]** menu will be displayed.
3. Use [▲] or [▼] to scroll to the **[Rack]** menu.
4. Press [Enter] to move the brackets underneath Control and use [▲] or [▼] to select the appropriate dimming rack or external processing rack control module.
5. If you have selected a dimming rack, move the brackets underneath **Rack** and use [▲] or [▼] to select either **DR6** or **DR12**.
6. Press [Enter] to move the brackets underneath **Volt** and use [▲] or [▼] to select the voltage that matches your feed, either **100-120**, **120 Delta** or **277 VAC**.
7. Press [Enter] to move the brackets underneath **Start** and use [▲], or [▼] to enter a DMX512 starting address for your rack between **001** and **512**.

DMX start address - the DMX512 channel number (between 1 and 512) applied to the first dimmer in the rack. Succeeding DMX channel numbers are automatically applied to the remaining dimmers.

Continued on next page...

```
Menu Control Rack
[Rack] Unknown ER4
```

```
Menu Volt
Rack[ 100-120 ]
```

```
Menu Start
Rack [ 001 ]
```

```
Menu Sequencing
Rack [ Straight ]
```

- Press [Enter] to move the brackets underneath **Sequencing**. Select either **Straight** or **Balanced**.

Straight or Balanced refers to how the DMX addresses will be distributed to the dimmers. Straight indicates that the distribution will be sequential starting at one. Balanced indicates that sequential loads will be distributed evenly over the three phases in the rack.

```
Update Rack? [Yes]
```



Note: Single-phase racks cannot be phase balanced, as the racks are not split evenly.

- Press [Enter] then [Exit]. The display changes to **Update Rack?** Use [▲] or [▼] to select Yes. Press [Enter] again to save changes and leave the **Rack** menu.

To detail dimming circuits

The Unison dimming processor is designed to control (dim) multiple lighting circuits. Control of each circuit is based on installed module type, connected load type, DMX address and circuit mode.

```
Menu      Ckt
[Cnfg]    001
```

- Access configuration menu (press the Unison Menu activation button.)
- Scroll to [Cnfg] with [▲] or [▼] and press [Enter]. The brackets move to the circuit number.



Note: Circuit numbers start with "1" for the first dimmer in the top slot of the rack. A rack can have one or two dimmer circuits per module. Dimmer load wire lugs are also labeled by circuit number.

```
Menu      Circuit
Cnfg      [001]
```

- Select the desired circuit number with [▲] or [▼] and press [Enter]. The display changes to **Module Type**.

```
Ckt      Module
001     [ D15/D20 ]
```

- Select the correct module type with [▲] or [▼] and press [Enter]. The display changes to **Load Type**.

Table 1: Dimmer modules and load types

Module Type	Description	Compatible loads
100-120 Volt Rack		
AFM	Required in empty dimmer slots	None
D15 and D20	Standard 15 or 20 amp dimmer	Incandescent, 2- and 4-wire fluorescent, Low voltage, Neon, Cold cathode (CC), Non-Dim
D15E and D20E D15G and D20G	500µs rise time 300µs rise time	
R15 and R20	15 and 20 amp mechanically held relay	
D15F and D20F	15 and 20 amp fluorescent dimmer	3 wire fluorescent dimmer ballasts
CC 15 and CC 20	Direct connection from line lug to load lugs protected by a 15 or 20 amp circuit breaker	Non-dim loads like color changer power supplies
277 Volt Rack		
AR15 and AR20	15 and 20 amp mechanically held relay	Any switched load
AD15 and AD20	15 and 20 amp dimmer 200µs rise time	Incandescent, 2- and 4-wire fluorescent, Low voltage, Neon, Cold cathode (CC), Non-Dim
AD15F and AD20F	15 and 20 amp fluorescent dimmer	



Note: "CC" (constant current) module types do not indicate Cold Cathode.

Ckt Load Type
001 [Incandescent]

- Select the desired load type with [▲] or [▼] and press [Enter]. The display changes to **DMX**. The number displayed refers to the DMX channel.



Note: When the Airflow module is selected the display goes directly to the **Save Changes?** screen. The display returns to the **Ckt** screen where you can begin detailing another circuit.

Table 2: Load type setting options

Load type	Setting options
Non-dim	DMX512 channel
Fluorescent (2, 3, 4 wire)	DMX512 channel, Ballast Type
Incandescent	DMX512 channel, DD (Dimmer Doubling) settings
Low Volt	DMX512 channel
Neon, CC (Cold Cathode)	DMX512 channel, Ballast Type

Ckt DMX
001 [001]

- Select the desired DMX512 address with [▲] or [▼] and press [Enter]. The brackets move to **Mode**.

Ckt Mode
001 [DD_Off]



Note: It is important to note the circuit to DMX channel assignments. Select the **DD** mode with [▲] or [▼] and press [Enter]



Caution: Dimmer doubling is only available in 120V systems using Source Four fixtures with 77V lamps.

Ckt Ballast Type
001 [1%]

- If a 2-, 3-, 4-wire fluorescent or Neon/CC is selected in load type the display will move to **Ballast Type**. Use [▲] or [▼] to scroll to the correct type.
- Use [▲] or [▼] to scroll to **[Yes]** to record your changes or scroll to **[No]** to discard changes and press [Enter]. The display returns to the circuit number step of the **[Cnfg]** menu. Use [▲] or [▼] to begin configuring another dimmer circuit. Or press [Exit] to leave the Configuration submenu.

Save Changes? [Yes]

To enter Dimmer Doubling (DD) settings

Dimmer Doubling (DD) can only be used in 120V systems using D15, D20, D15E, and D20E modules. This feature is used for applications where ETC Dimmer Doubling and Source 4 equipment is used. If you have not purchased Dimmer Doublers, this feature must be turned off.

Ckt Mode
001 [DD_Off]

- Select either **[DD_On]** or **[DD_Off]** with [▲] or [▼] to enable or disable Dimmer Doubling and press [Enter]. If you select **[DD_On]** the display changes to **[DD_DMx]**. If you select **[DD_Off]**, **Save Changes?** displays.

Ckt DD_DMx
001 [257]

- Select the desired DMX512 address with [▲] or [▼] and press [Enter]. Use the default address number (the **DMX** address plus 256) unless a different address is specified. The display changes to **[Save Changes?]**.

To set dimmer levels in the Test submenu

You can use the Test submenu to set dimmer levels to test your dimmer circuit wiring or lighting load operation. Test also allows you to view DMX levels being received by the dimming processor.

Menu	Ckt	Level
[Test]	001	000

Menu	Ckt	Level
Test	[001]	000

Menu	Ckt	Level
Test	001	[000]

Restore DMX?	[Yes]
--------------	-------

1. Access the configuration menu (press the Unison Menu activation button.)
2. Scroll to **[Test]** with **[▲]** or **[▼]** and press [Enter]. The brackets move to **Ckt**. The DMX input value for that circuit is displayed between a range of 0 and 255.

3. Use **[▲]** or **[▼]** to scroll to the desired circuit number and press [Enter]. The brackets move to **Level**. **This shuts off all DMX to the rack. DMX levels are held at last look and DMX level changes have no effect.**

4. Use **[▲]** or **[▼]** to scroll to the circuit output level. Circuit output will continuously match the levels as they scroll. Press [Exit] to set levels on another circuit or [Enter] to go to **Restore DMX?**. (Restoring DMX will cancel all test levels.)



Note: Circuit levels will remain at their test setting when you press [Exit]. You can set levels for all the dimmer circuits by repeating steps 2 and 3.

5. Use **[▲]** or **[▼]** to scroll to **[Yes]** to clear the test settings and restore DMX or **[No]** to temporarily keep the look and press [Enter].



Note: If you keep the test settings, DMX512 input is disabled until you return to the **Test menu** and restore DMX.

To set dimmer levels in the Set All submenu

The **[Set All]** submenu is an additional test menu. It allows you to change all of the levels in the dimmer rack.

Menu	Level
[Set All]	---

1. Access the configuration menu (press the Unison Menu activation button.)
2. Scroll to **[Set All]** with **[▲]** or **[▼]** and press [Enter].
3. Use **[▲]** or **[▼]** to change the level of all dimmers.
4. Press [Enter], and use **[▲]** or **[▼]** to scroll to [Yes] to clear the [Set All] and restore DMX. Or [No] to temporarily keep the look and press [Enter].

To set the Backup look

In the event of console failure, the backup look enables you to activate a single preset at the CMd or CMEd.

Menu	Mode
[Backup]	None

1. Access the configuration menu.
2. Scroll to **[Backup]** with [▲] or [▼] and press [Enter]. The brackets move to **Mode**.

Menu	Mode
Backup	[Record]

3. Scroll to **[Record]** with [▲] or [▼] and press [Enter]. The system will record current levels.



Note: Any "Test" or "Set All" levels will also be recorded if DMX is not active.

Menu	Play At Boot
Backup	[No]

4. Use [▲] or [▼] to select if programmed backup look should play at boot-up of system processor. Select **[Yes]** or **[No]** and press [Enter].

Save Changes?	[Yes]
---------------	-------

5. Scroll to [Yes] to save changes and press [Enter].



Note: playing the backup look will disable DMX or test levels to the dimming rack.

Configuring the Architectural Processor

Application and Light Manager software version 1.65

You configure the architectural processor for your system using the Unison (Architectural) menu. This menu lets you load the provided configuration, enter the Unison local control settings and other information used by the control processor.

Each Unison control system has one architectural processor.

- ▼ If your system has an External Processing Rack, its control module will contain the architectural processor.
- ▼ If your system does not have a processing rack, the architectural processor is in the control module of one of your Unison Dimmer Racks.



Note: You can tell which dimming rack control module contains the architectural processor by looking at the label on the right side of the faceplate. CMBd, CMEd and CMEi control modules contain an architectural processor. CMd modules do not.

From the dimming rack

- ▼ Access the Unison menu and scroll to [ARCH] with [▲] or [▼] and press [Enter]. The Unison menu will be displayed.

From the external processing rack

- ▼ Access the Unison menu and scroll to [ARCH] with [▲] or [▼] and press [Enter]. The Unison menu will be displayed.

To load a Unison Light Manager configuration into the control processor

The Light Manager configuration provides system parameters such as number of rooms, number of zones in each room, number of presets and type and placement of stations.

1. Open the rack door and find the 3.5" disk drive slot on the right side of the Control Module.
2. Insert the disk containing the configuration into the drive.
3. Access the Unison menu and scroll to **[Load from Disk]** with [▲] or [▼] and press [Enter].
4. Scroll to the desired configuration name with [▲] or [▼] and press [Enter].

```
Unison Menu (v1.65)
[Load from disk]
```

```
Choose Configuration
[ATRIUM]
```



Note: Reading a configuration will overwrite the configuration currently in the processor. Save to disk before reading in a new configuration if you are unsure.

```
Loaded
"ATRIUM" Enter
```

5. **Loaded** displays when the configuration is loaded from the 3.5" floppy disk. Press [Enter] to return to the **Unison** menu.



Note: It is recommended that you reset the system after loading a configuration to save your internal flash memory.

To bind control stations to the architectural processor

Before the architectural processor can identify signals from the wall stations, it has to link each control station to its ID number. This process is called "binding". Systems with a single station of a particular type (preset, fader, LCD) will automatically bind with the associated ID number.

Unison Menu (v1.65)
[Setup]



1. Access the Unison Menu, scroll to **[Setup]** with **[▲]** or **[▼]** and press [Enter].

Note: Refer to the Control Station ID Chart to find the station ID number of the control you wish to bind.

Setup
[Stations]

2. From the **Setup** display scroll to **[Stations]** with **[▲]** or **[▼]** and press [Enter].

Stations
[Connect]

3. From the **Stations** display, scroll to **[Connect]** with **[▲]** or **[▼]** and press [Enter].

Choose Room
[Dining]

4. The **Choose Room** display shows a list of rooms with unbound control stations. Scroll to the desired room with **[▲]** or **[▼]** and press [Enter].

Choose Section
[Banquet]

5. The **Choose Section** display shows the sections available in divided rooms. Scroll to the desired section with **[▲]** or **[▼]** and press [Enter].



Note: If the selected room is not divided, this display is skipped.

Choose Station
[Fader 1]

6. The **Choose Station** display scrolls the names of unbound control stations in the section. Scroll to the desired control station with **[▲]** or **[▼]** and press [Enter].

Connect to:
[0000 - 6032 - 6783]

7. When a control station name is selected, the **Connect to** display shows a list of the station IDs available on the network for that type of station. Scroll to the correct ID with **[▲]** or **[▼]** and press [Enter].



Note: When you are in the **Connect menu**, pressing a control button on the station you choose in Step 6 will display the ID number of that station. You can use this feature to bind stations if you lose your Control Station ID Chart.

"Fader 1"
Connected Enter

8. The LCD will display **[Connected]** when the station is bound. The control station is now ready. Press [Enter] to show the next room or section with unbound control stations. Press [Exit] to leave the **Connect** menu.



Note: After binding stations, ETC recommends saving the configuration.

To unbind control stations (optional)

When you need to remove or change a station, follow this procedure to unbind a control station from the architectural processor.

Unison Menu (v1.65)
[Setup]

Setup
[Stations]

Stations
[Disconnect]

Choose Room
[Dining]

Choose Section
[Banquet]

1. Access the Unison Menu, scroll to **[Setup]** with **[▲]** or **[▼]** and press [Enter].

2. Scroll to **[Stations]** with **[▲]** or **[▼]** and press [Enter].

3. Scroll to **[Disconnect]** with **[▲]** or **[▼]** and press [Enter].

4. In the **Choose Room** display **[▲]** or **[▼]** scrolls the names of rooms with bound control stations. Press [Enter] to select the desired room.

5. In the **Choose Section** display **[▲]** or **[▼]** scrolls the names of sections with bound control stations. Press [Enter] to select the desired section.



Note: The Choose Section display is skipped for undivided rooms.

Stn 0000-6032-6783
[Fader 1]

"Podium"
Disconnected Enter

6. After you select the section, the display shows a scrolling list of linked stations in that location. Scroll to the desired station with **[▲]** or **[▼]** and press [Enter].

7. The message **"Disconnected"** displays when the control station has been unbound. Press [Enter] to move to the next section or room with bound control stations. If there are no remaining bound control stations in the configuration, the display reverts to the Stations Connect menu.

Unison Menu (v1.65)
[Setup]

8. Press [Exit] to move back through the **Stations** submenu until you return to the **Unison** menu.

To enter the Date and Time local control settings

Follow this procedure to set the date and time in the astronomical time clock in the architectural processor.

Unison Menu (v1.65)
[Setup]

1. Access the Unison Menu, scroll to **[Setup]** with [▲] or [▼] and press [Enter].

Setup
[Date/Time]

2. Scroll to **[Date/Time]** with [▲] or [▼] and press [Enter].

Year
[2000]

3. The **Year** display scrolls dates from **[1995]** to **[2099]** with [▲] or [▼]. Press [Enter] to select the correct year.

Month
[October]

4. The **Month** display scrolls all 12 months with [▲] or [▼]. Press [Enter] to select the correct month.

Date
[9]

5. The **Date** display scrolls days from 1 to 31 with [▲] or [▼]. Press [Enter] to select the correct date.

Hour
[11 AM]

6. The **Hour** display scrolls 24 hours in a 12 hour AM/PM format with [▲] or [▼]. Press [Enter] to select the correct hour.

Minute
[11]

7. The **Minute** display scrolls from 00 to 59 minutes with [▲] or [▼]. Press [Enter] to select the correct minute.

Date/Time
Set Enter

8. **Date/Time Set** appears when the Date/Time menu is complete. Press [Enter] to return the display to the **Unison** menu.

To enter your location settings

The Location menu allows you to enter the installation latitude, longitude, elevation, and time zone into the Unison astronomical time clock. Refer to the Location Map on page 37.

Unison Menu (v1.65)
[Setup]

Setup
[Location]

Longitude (deg)
[89 West]

Longitude (min)
[30]

Latitude (deg)
[43 North]

Latitude (min)
[15]

Altitude (feet)
[900]

Time Zone (hours)
[-6]

Daylight Savings
[Observed]

Location
Set Enter

1. Access the Unison Menu, scroll to **[Setup]** with [▲] or [▼] and press [Enter].
2. Scroll to **[Location]** with [▲] or [▼] and press [Enter].
3. The **Longitude (deg)** display scrolls from 0 to 179 degrees East and West with [▲] or [▼]. Press [Enter] to select the correct value.
4. The **Longitude (min)** display scrolls from 0 to 59 minutes of longitude with [▲] or [▼]. Press [Enter] to select the correct value.
5. The **Latitude (deg)** display scrolls from 0 to 89 degrees North and South with [▲] or [▼]. Press [Enter] to select the correct value.
6. The **Latitude (min)** display scrolls from 0 to 59 minutes of latitude with [▲] or [▼]. Press [Enter] to select the correct value.
7. The **Altitude display** scrolls elevation values in increments of 100 feet (28.5m) with [▲] or [▼]. Press [Enter] to select the correct value.
8. The **Time Zone** display scrolls from 1 to 12 hours before (+) or after (-) Greenwich Mean Time. Scroll to the correct Time Zone with [▲] or [▼] and press [Enter].
9. The **Daylight Savings** display scrolls from **[Observed]** to **[Not Observed]** with [▲] or [▼]. Press [Enter] to select the desired daylight savings setting.
10. **Location Set** displays when the Set Location menu is complete. Press [Enter] to return to the **Unison** menu.

Working in the Setup menu

All of the following Setup menu options will allow you to access, change or set information about your Unison system. See "Appendix E: Architectural Menu Flow Chart" on page 33, for help on maneuvering through the menus.

Setup
[Stations]

▼ Stations

Use this menu to connect (bind) or disconnect stations to the Unison processor. See page 12.

Setup
[Zones]

▼ Zones

Use this menu to change a zone's level, add a dimmer, remove a dimmer, or change the DMX input mode.

Setup
[Presets]

▼ Presets

This option will let you activate, deactivate, record and change the fade time of a Preset.

Setup
[Walls]

▼ Walls

Use this menu to open or close a wall.

Setup
[Load Net Backup]

▼ Load net backup

Loads configurations over the network in special Master Controller applications.

Setup
[Date/Time]

▼ Date/Time

Allows you to display or change timeclock information about the system. See "To enter the Date and Time local control settings" on page 14.

Setup
[Location]

▼ Location

Allows you to display or change astronomical timeclock information about the system. See "To enter your location settings" on page 15.

Setup
[Format disk]

▼ Format disk

See page 20 for more information.

Setup
[Processor/Address]

▼ Processor/Address

Sets the Processor IP address for all applications.



Note: If you change this address, you must reset the control module for the changes to take affect.

Setup
[Information]

▼ Information

This menu option gives you detailed information about your configuration, including: numbers of stations and connectors, numbers of rooms and sections, numbers of zones and dimmers, presets and their levels, and processor addresses. See "Working in the Setup Information Menu" on page 17.

Working in the Setup Information Menu

Setup
[Information]

The following Setup menu options will allow you to access, change or set information in the Setup Information menu.

Setup Information
[Stn: Con:]

- ▼ Number of stations and number of connected stations in the configuration. "Stn:" indicates number of stations in the Light Manager configuration. "Con:" indicates number of bound physical station on the Union Link Power (ULP) network.

Setup Information
[Rms: Sec:]

- ▼ Number of rooms and sections in the configuration

Setup Information
[Zon: Dim:]

- ▼ Number of zones and dimmers in the configuration

Setup Information
[Pre: Lev:]

- ▼ Number of presets and levels in the configuration

Setup Information
[Nam:]

- ▼ Job or configuration name

Setup Information
[Num:]

- ▼ Job or configuration number

Setup Information
[Loc:]

- ▼ Job location

Setup Information
[Eng:]

- ▼ Job engineer

Setup Information
[USAP Good]

- ▼ Number of good Unison Serial Access Protocol (USAP) commands received

Setup Information
[USAP BadObj]

- ▼ Number of USAP commands with bad objects

Setup Information
[USAP BadStrt]

- ▼ Number of premature start bits

Setup Information
[USAP BadLen]

- ▼ Number of commands that were the wrong length

Setup Information
[MAC addr:]

▼ MAC address in Hex

Setup Information
[IP:]

▼ IP address

Setup Information
[MK:]

▼ IP Mask number

Setup Information
[GW:]

▼ IP Gateway number

Setup Information
[CID:]

▼ CID number

Working in the Diagnostics menu

As with the Setup menu, the Diagnostics menu will allow you to access advanced information about your configuration.

Diagnostics
[Run Macro]

- ▼ Run Macro
Runs selected Macro.

Diagnostics
[Stop Macro]

- ▼ Stop Macro
Stops selected Macro.

Diagnostics
[Dimmers]

- ▼ Dimmers
This menu option gives you the specific DMX level information for the selected dimmer.



Note: Dimmer: Ei Di -> Eo Do

This screen in the [Dimmer] menu shows you the current EDMX and DMX levels going in and out of the processor.

Diagnostics
[Stations]

- ▼ Stations
Use this menu to find out which stations (and their ID numbers) are connected to the network.

Diagnostics
[All Zones Off]

- ▼ All Zones Off
Turns off all zones that are currently on.

Diagnostics
[Initialize Flash]

- ▼ Initialize Flash
Clears and resets the current flash memory. This will erase the internal system memory.

Diagnostics
[Reset Stations]

- ▼ Reset Stations
By selecting this option you will be performing a power-only reset on the AUX and Unison Link Power (ULP) lines.

Diagnostics
[Send Object Model]

- ▼ Send Object Model
Used in specialized networked systems to send information about controls and wall stations.

The write-protect tab must be in the "Write" position to format a disk

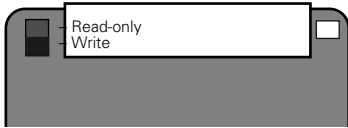

Figure 2: Write tab position

To format floppy disk (optional)

If you have an unformatted double-sided, high-density disk, you can format it in the Control Module's disk drive.

1. Insert the disk into the disk drive on the right side of the control module. The write-protect tab must be closed. See *Figure 2*.

```
Unison Menu (v1.65)
[Setup]
```

```
Setup
[Format disk]
```

```
Formatting
disk...
```

```
Formatting failed!
er:05 Enter
```

2. Access the Unison Menu, scroll to **[Setup]** with **[▲]** or **[▼]** and press [Enter].

3. Scroll to **[Format Disk]** with **[▲]** or **[▼]** and press [Enter]. **Formatting disk...** displays while the Control Module is formatting the disk. Formatting may take a few moments.

▼ **"Disk Formatted"** displays if formatting is successful. The disk is ready to record a configuration.

▼ **Formatting failed!** displays if there is a problem formatting the 3.5" floppy disk. You should check the write-protect tab or use another disk.

To save the installed configuration

You should keep a copy of your installed Unison configuration to another 1.44 MB IBM DS HD format 3.5" floppy disk (not your original configuration disk.) Saving the installed configuration records binding and location information entered while binding stations and setting up the system.

```
Unison Menu (v1.65)
[Save to disk]
```

```
Choose Save Name
[UNISON-1]
```

```
Saved
"UNISON-1" Enter
```

1. To use the **Save to disk** submenu, insert a correctly formatted disk (see Preparing a 3.5" floppy disk, above), access the Unison menu, scroll to **[Save to disk]** with **[▲]** or **[▼]** and press [Enter].

2. The **Choose Save Name** display scrolls the nine name options used by the Control Module processor for saving configurations. Names begin with **Unison** and are numbered from 1 to 9. Scroll to the desired name with **[▲]** or **[▼]** and press [Enter].

3. **Saved** displays when the configuration is saved to the 3.5" floppy disk. Press [Enter] to return to the **Unison** menu.

Maintaining Your Unison System

Cleaning dimming rack air filters

Clean the filter on your dimmer cabinet every six months, more often if your system operates in a dusty environment.



Caution: Phase voltages inside the rack can be deadly. Do not remove rack modules. Only qualified technicians should expose the inside of the dimming cabinet. The Unison dimmer rack carries only an IP00 protection rating when control or dimmer modules are removed.

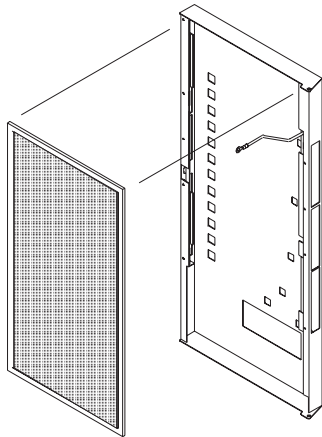

1. Open the dimmer rack door. The filter is mounted on the inside of the door, held in on the bottom by a metal clip.
2. Slide the filter up about 1/2 inch until the filter base clears the top edge of the lip. Pull the base out far enough to clear the retaining lip and slide the filter down and out.
3. Vacuum or blow dust out of the filter.



Note: You can wash the filter under clear tap water, but it must be completely dry before you reinstall it. Do not use soap or other chemicals to clean the filter.

4. Slide the top of the filter back into the slot at the top of the door until the base clears the metal retaining lip on the bottom of the door.



Note: When you clean the air filter, you should also check the dimmer air vents for dust. See "Vacuuming Dimming Racks" below.

5. Let the filter drop back into place and close the door.

Figure 3: Removing a Unison DR or ER air filter

Vacuuming Dimming racks

You should inspect your dimming rack when you clean the air filter and vacuum the front of the dimmer modules if necessary.

1. Open the door and look at the modules' air vents. If dust is thick enough to hide the paint color, vacuum the front of the modules.
2. Leave the modules inside the rack. Most dust collects on the dimmer choke vents and grills of the dimmer module.
3. Use a narrow vacuum cleaner nozzle to vacuum dimmer module air vents. Do not push debris into the modules.
4. Close the door.

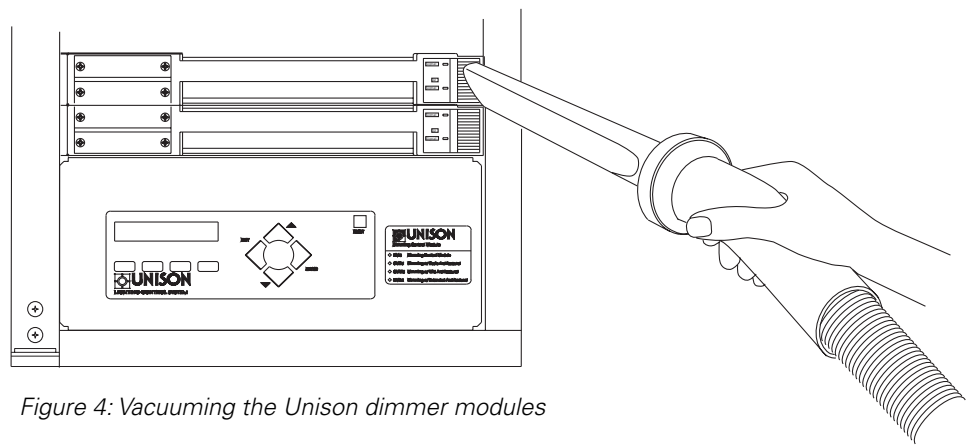

Figure 4: Vacuuming the Unison dimmer modules



Appendix A: Frequently Asked Questions

What voltage is required for the LCD station to operate?

The voltage at the LCD should be at least 9.5Vdc. If the voltage is too low the LCD will get into a power cycling mode. The cycle is created when the backlight circuit draws more current during the power-up stage, causing the voltage to drop to 5Vdc and reset the unit. The unloaded output voltage of the AUX control power supply is set at 24Vdc at the factory. The maximum output voltage is about 14Vdc.

Can I measure the voltages on the link power network to check for faults?

Yes, with a digital volt meter(DVM). Set the DVM to read DC volts and measure the voltage across the link power terminals, it should read plus or minus 40.5Vdc +/- 1Vdc. The polarity is not important. Also measure the voltage from each link power terminal to an earth ground connection. The voltage should read either plus or minus 20.25Vdc +/- 1Vdc. One terminal will be 20.25 referenced to earth ground and the other will be -20.25Vdc referenced to earth ground. Abnormal reading will warrant an investigation to find the fault.

Can any control module be hot-swapped?

No, the inrush current that charges the input capacitors is enough that it can arc across the card edge connectors. This can damage the connectors and create high resistance hot-spots on the connectors. Turn off the power feed breaker to the rack when changing control modules.

I have a multi-rack DR12 system and a CMEd/CMBd control module driving a series of wall stations. None of the wall stations seem to be getting power, what's wrong?

If the wall stations are wired to a properly installed architectural option PCB in one of the racks, it is likely that the control module installed in that rack does not contain an architectural processor. The CMEd/CMBd must be located in the same rack to which the wall stations are wired.

I have a DR12 and regardless of what I do only modules 1,2,3,6,9 and 10 do anything.

The control module is configured for a 6 module rack. To fix the problem enter the **Rack** initialization menu and under the field [Rack] select [DR12]. Remember, the menu is entered by holding the hidden key located just above the second 'N' in UNISON on the membrane overlay. See page 5 for rack initialization instructions.

I have one or two loads that seem to cycle periodically. When they are off, they're off for about 2 minutes, then it comes back on. What's wrong?

It is likely that you have an over-temperature problem due to the accumulation of dust in the air filter. The Unison series will attempt to restart the over-temperature module after approximately 2 minutes. Overtemp conditions are detected on a by-module basis. Thus, all circuits that are controlled by the module will be shut down.

Can the stations be reset without resetting the control module?

Yes, from the [Diagnostics] section of the Architectural menu. Scroll through the menu until the [Reset Stations] selection appears and hit [Enter]. This will reset the AUX control power and the link power supplies, which will reset all the stations on the network.

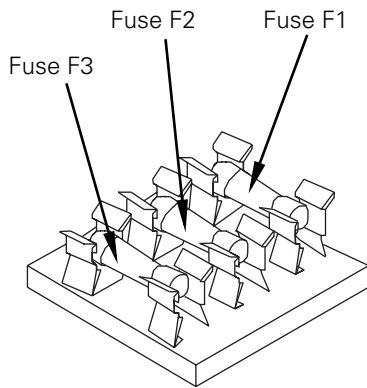

Figure 5: 277V fuse block

My control module/stations/fan won't work. What's wrong? (277V only)

Most likely you have blown fuse F1 and it should be replaced. Fuses are located at the bottom of the rack on the left side of the enclosure. See *Figure 5* for location of fuses.

I can't access my [ARCH] menu. I've got a dimmer rack with a CMBd/CMEd control module.

If a functioning architectural processor is installed, first enter the [RACK] menu. Scroll to [VOLT] (or any other field), scroll up once, scroll down once (the field should be unchanged). Exit the [RACK] menu, answering [YES] to "Save Changes". Reset the control module. You should now be able to access the architectural processor if it exists.

This only occurs in dimming control modules with Architectural processing. Upon initial power-up the interface processor waits approximately 45 seconds for the Architectural processor to initialize. If the architectural processor does not come on-line in that period, it is assumed that the architectural processor does not exist and that information is written to non-volatile memory. Without an architectural processor, boot time is reduced from 45 seconds to 10 seconds as the interface processor simply ignores the architectural processor. The above procedure forces the interface processor to re-recognize the architectural processor if it exists.

I'm getting a "Zero Crossing" error on my control module. What does that mean? (277V only)

Either fuse F2 or F3 needs to be checked and/or replaced. Fuse F2 is for phase C, and F3 for phase B. See *Figure 5* for location of fuses.

I have plugged in my control processor and all the zones have come to full.

Go into the Unison setup menu and scroll to the [DIAGNOSTIC] menu. From there scroll to "all zones off ". This will take all levels to zero and you can finish installing the system.

I am trying to communicate with the Unison PC interface, but cannot get a connection.

Make sure that when you attach to the processor that Light Manager is not running. Make the serial connection first, then start Light Manager and try to get a connection. Also check *File/Setup PC Interface* for the correct COM port. Reboot if necessary.

I have a portable station that will not work when I plug it into any of the portable connectors.

When you first install a Unison system with portable stations you must first bind the portable station to each of the portable connectors. After that the portable station will know where it is connected and will work automatically.

I have a Preset station and when I try to play a preset all the LEDs chase.

If the station LEDs chase, it means the station is not "bound" to the processor. Follow the steps on page 12 to manually bind the station.

How do I bind stations?

See "To bind control stations to the architectural processor" on page 12.

How many stations can I connect/What are the differences between processors?

- ▼ CMB - Basic architectural processor
 - 128 dimmers
 - 8 rooms
 - 1200 recordable levels
 - 16 stations (5 LCD)
- ▼ CME - Extended architectural processor
 - 512 dimmers
 - 64 rooms
 - 10000 recordable levels
 - 128 stations (5 LCD)
- ▼ CMEi - Extended architectural processor with network connections
 - 512 dimmers
 - 64 rooms
 - 10000 recordable levels
 - 126 stations (5 LCD)

My LCD screen looks all scrambled

Bitmap files for fonts and graphics have become corrupted. Try reloading your configuration. If you still have problems, contact ETC Technical Services at 800-775-4382.

I try to bind stations, and all I get is "-----" at the processor.

Either the station is already bound or is not being recognized by the processor. Check the link power connection.

Does it matter what I call my configuration?

No, provided it has a ".cfg" suffix.

How do I play/stop a Backup look?

You need to go into the Unison menu, and under **[Backup]** select [Play] or [Stop]. See "To set the Backup look" on page 9.

I set my Backup look to play at boot and now it won't stop.

You need to go into the Unison menu, and under **[Backup]** select **[Stop]** and "Play At Boot" **[No]**. See "To set the Backup look" on page 9.

How do I upgrade my processor to a newer version of code?

Contact ETC Technical Services.

My processor will not read disks.

There might be a problem with the floppy drive. Call ETC Technical Services.

How long should the processor say "Booting"?

Depending on the size of the configuration and number of stations, the processor can display this message for a minute or more.

I keep pressing Reset on the CEM to reset my UPSAC, but the stations still don't work.

The UPSAC system has an external Unison power supply that must be reset as well.

I plugged in my PC to the Interface station. How do I "talk" to the processor?

See the *Unison Light Manager Manual*, *To configure a PC for live control*, page 44 for details.

I want to record looks that I have set on my console to presets, how does that work?

In the *Unison Light Manager Manual*, see *Modifying Zone Properties*, page 22.

Appendix B: Error Message Chart

Upon starting and during operation of your system, the control module will display messages to indicate system status.

DISPLAY MESSAGES	STATUS	SUGGESTED SOLUTION
System OK	System operating correctly	None required
Backup Active	Backup look playing	Turn backup look off
Test DMX Off	Test menu active	Restore DMX in test menu
Errors Exist	1 or more circuits have specific errors	Scroll through error list

If errors exist, use the right arrow button to scroll through the list of circuits and associated errors. Multiple errors can be seen by pressing [▲] or [▼].

Possible error types include:

DISPLAY MESSAGES	STATUS	SUGGESTED SOLUTIONS
SSP_ERR	Indicates I ² C error	Cycle power - Call factory
No DMX	DMX is not being received	Hook up DMX or turn on console
DMX ERR	Bad DMX packets being received	Verify DMX wiring and termination
No Zero	One of the phases has failed to detect zero crossing. System is likely inoperable.	Call factory
Over Temp	One or more of the dimming modules has been shut off due to sensing of over-temp.	Make sure fan is running - Check rack filter - Check module input vents - Replace module.
Voltage Low	Rack is receiving insufficient voltage for initialized parameters.	Verify input voltage
Voltage High	Rack is receiving excess voltage for initialized parameters.	Verify input voltage
Arch Failure	The control module has been configured as a CME/CMEd or CMB/CMBd and communication with the architectural processor cannot be established.	The control module must be configured as a dimming module in the [Rack] menu, or call ETC.
Bypass Active	A power failure in the normal power feed was sensed. Dimmers have been driven to full, bypassing all control.	Restore normal power.
CPU 01 - 06 Fail	A dimming processor in a -d module has failed.	Call ETC

ETC contact information

- ▼ Technical Service phone: **800-775-4382**
 - ▼ Technical Service fax: **800-836-1736**
 - ▼ System and Light Manager questions may be directed to: **lightmanager@etcconnect.com** or **service@etcconnect.com**
- In the event of an emergency, for faster service please call the factory.

Appendix F: Dimmer Menu Flow Chart

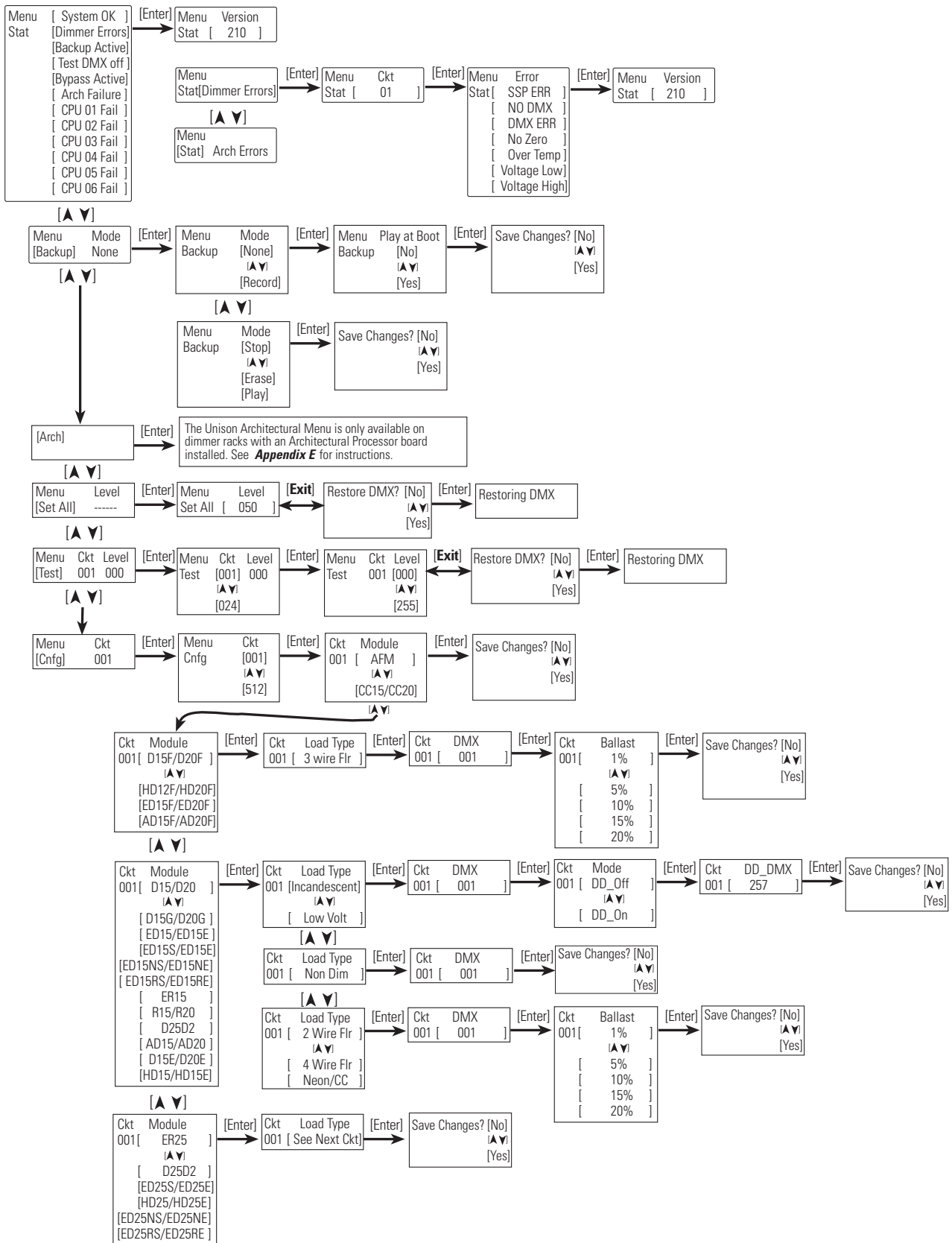

Appendix G: U.S. Time Zone and Location Map



Table 3: Longitude, Latitude and Time Zones of Major Cities

City and State	Time Zone	Latitude	Longitude	City and State	Time Zone	Latitude	Longitude
Anchorage, AK	-10 G.M.T.	61° 10' N	149° 11' W	Fargo, ND	-6 G.M.T.	46° 52' N	96° 49' W
Montgomery, AL	-6 G.M.T.	32° 21' N	86° 17' W	Albuquerque, NM	-7 G.M.T.	35° 07' N	106° 37' W
Little Rock, AR	-6 G.M.T.	34° 43' N	92° 21' W	Las Vegas, NV	-7 G.M.T.	36° 12' N	115° 13' W
Phoenix, AZ	-7 G.M.T.	33° 32' N	112° 04' W	Buffalo, NY	-5 G.M.T.	42° 53' N	78° 51' W
Tucson, AZ	-7 G.M.T.	32° 11' N	110° 53' W	New York, NY	-5 G.M.T.	40° 46' N	73° 58' W
Los Angeles, CA	-8 G.M.T.	34° 05' N	118° 24' W	Syracuse, NY	-5 G.M.T.	43° 02' N	76° 08' W
San Diego, CA	-8 G.M.T.	32° 48' N	117° 08' W	Cincinnati, OH	-5 G.M.T.	39° 08' N	84° 31' W
San Francisco, CA	-8 G.M.T.	37° 47' N	122° 33' W	Cleveland, OH	-5 G.M.T.	41° 8' N	81° 40' W
Denver, CO	-7 G.M.T.	39° 46' N	104° 52' W	Oklahoma City, OK	-6 G.M.T.	35° 28' N	97° 30' W
Hartford, CT	-5 G.M.T.	41° 45' N	72° 41' W	Portland, OR	-8 G.M.T.	45° 32' N	122° 39' W
Washington D.C.	-5 G.M.T.	38° 54' N	77° 00' W	Pittsburg, PA	-5 G.M.T.	40° 26' N	79° 58' W
Miami, FL	-5 G.M.T.	25° 49' N	80° 13' W	Philadelphia, PA	-5 G.M.T.	40° 00' N	75° 08' W
Tampa, FL	-5 G.M.T.	27° 57' N	82° 28' W	Providence, RI	-5 G.M.T.	41° 49' N	71° 25' W
Atlanta, GA	-5 G.M.T.	33° 45' N	84° 25' W	Charleston, SC	-5 G.M.T.	32° 47' N	79° 59' W
Savannah, GA	-5 G.M.T.	32° 01' N	81° 07' W	Sioux Falls, SD	-6 G.M.T.	43° 32' N	96° 43' W
Honolulu, HI	-10 G.M.T.	21° 79' N	157° 48' W	Memphis, TN	-6 G.M.T.	35° 06' N	90° 00' W
Des Moines, IA	-6 G.M.T.	41° 34' N	93° 37' W	San Antonio, TX	-6 G.M.T.	29° 27' N	98° 30' W
Boise, ID	-7 G.M.T.	43° 36' N	116° 13' W	Dallas, TX	-6 G.M.T.	32° 47' N	96° 45' W
Chicago, IL	-6 G.M.T.	41° 50' N	87° 41' W	Fort Worth, TX	-6 G.M.T.	29° 46' N	95° 23' W
New Orleans, LA	-6 G.M.T.	30° 03' N	89° 55' W	Salt Lake City, UT	-7 G.M.T.	40° 46' N	111° 55' W
Boston, MA	-5 G.M.T.	42° 20' N	71° 01' W	Richmond, VA	-5 G.M.T.	37° 31' N	77° 28' W
Baltimore, MD	-5 G.M.T.	39° 18' N	76° 36' W	Burlington, VT	-5 G.M.T.	44° 29' N	73° 13' W
Bangor, ME	-5 G.M.T.	45° 32' N	95° 10' W	Seattle, WA	-8 G.M.T.	47° 37' N	122° 21' W
Detroit, MI	-5 G.M.T.	42° 22' N	83° 06' W	Madison, WI	-6 G.M.T.	43° 04' N	89° 23' W
Minneapolis, MN	-6 G.M.T.	44° 57' N	93° 16' W	Milwaukee, WI	-6 G.M.T.	43° 03' N	87° 58' W
Kansas City, MO	-6 G.M.T.	39° 07' N	94° 33' W	Cheyenne WY	-6 G.M.T.	41° 08' N	104° 47' W
Billings, MT	-7 G.M.T.	45° 47' N	108° 32' W	Vancouver, B.C.	-8 G.M.T.	49° 15' N	123° 07' W
Lincoln, NB	-6 G.M.T.	40° 48' N	96° 41' W	Toronto, Ont.	-5 G.M.T.	43° 39' N	79° 23' W
Charlotte, NC	-5 G.M.T.	35° 11' N	80° 50' W	Montreal, Que.	-5 G.M.T.	45° 30' N	73° 36' W

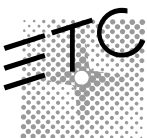

Americas • 3030 Laura Lane Middleton, WI 53562 • Tel: (+1) 608.831.4116 • Fax: (+1) 608.836.1736 • Toll free: 800.688.4116 • Toll free fax: 800.555.8912
Europe • 5 Victoria Industrial Estate, Victoria Road, London W3 6UU • Tel: +44 (0)20 8896 1000 • Fax: +44 (0)20 8896 2000
Asia • Room 605-606, Tower III Enterprise Square • 9 Sheung Yuet Road, Kowloon Bay • Kowloon, Hong Kong • Tel: (+852) 2799 1220 • Fax: (+852) 2799 9325
International • 3030 Laura Lane Middleton, WI 53562 • Tel: (+1) 608.831.4116 • Fax: (+1) 608.836.1736 • Toll free: 800.688.4116 • Toll free fax: 800.555.8912
Web: www.etconnect.com • **Email:** mail@etconnect.com

Copyright © 2000 Electronic Theatre Controls, Inc., All Rights Reserved. All product information and specifications subject to change. 7080M1006 Rev.B Printed in USA 06/00

