



Selador Series by ETC

Lustr – Paletta – Vivid CE User Manual

July 2009

The Selador series of fixtures are intended for professional use only.
Read entire User Manual before using equipment.

Copyright © 2009. Electronic Theatre Controls, Inc.
All rights reserved.
Product information and specifications subject to change.
Part Number: 7401M1210 Rev A
Released: 2009-07

ETC and Selador are registered trademarks of Electronic Theatre Controls, Inc. in the United States and other countries.

Other product and company names mentioned herein may be trademarks and/or service marks of their respective owners.

ETC permits the reproduction of materials in this manual only for non-commercial purposes. All other rights are reserved by ETC.

This product is protected by one or more of the following U.S. Patents: 6,016,038, 6,150,774, 6,788,011, 6,806,659, 6,683,423 and 7,023,543



DECLARATION OF CONFORMITY

We, Electronic Theatre Controls Limited
declare under sole responsibility that the product:

Product name: Selador LED luminaire
Product type/model: Vivid, Lustr and Paletta
Item numbers: All sizes

to which this declaration relates is in conformity with the following Standards:

EN 60598-1:2004 Luminaires. General requirements and tests
EN 60598-2-17:1989 Luminaires. Particular requirements. Specification for luminaires for stage lighting, television, film and photographic studios (outside and indoor)

following the provisions of EU LV Directive(s) 2006/95/EC

EN 55015:2006 Limits and methods of measurement of radio disturbance characteristics of electrical lighting and similar equipment

EN61000-6-2:2005 Electromagnetic compatibility (EMC). Generic standards. Immunity for industrial environments
Including:

EN61000-4-2:1995	ESD requirements
EN61000-4-3:2006+A1:2008	Radiated susceptibility
EN61000-4-4:2004	Electrical fast transients
EN61000-4-5:2006	Surges
EN61000-4-6:2007	Conducted susceptibility
EN61000-4-11:2004	Voltage dips and interruptions

EN61000-3-2:2006 Electromagnetic compatibility (EMC). Limits. Limits for harmonic current emissions (equipment input current up to and including 16 A per phase) Class C

EN61000-3-3:1995 Electromagnetic compatibility (EMC). Limits. Limitation of voltage fluctuations and flicker in low-voltage supply systems for equipment with rated current ≤ 16 A

following the provisions of EU EMC Directive(s) 2004/108/EC

London, United Kingdom
(Place of issue)

25th June 2009
(Date of Issue)

Mr Adam Bennette
(Name of authorised person)



(signature of authorised person)

Table of Contents

Specifications	1
Maximum Power Consumption at Full Intensity	2
Dimensions and LEDs	2
Note About LED Fixtures	2
Overview	3
Applications	4
Document Conventions	5
Safety	5
Installation	6
Power and Data Cabling Requirements	6
Power	6
Data	6
Installation Procedures	7
Installing Mounting Hardware	7
Installation Clearances	7
Safety Cable	9
Fixture Weight	9
Installing Secondary Lenses	10
Connections and Addressing	11
Control	12
Routine Maintenance	14
General Fixture Cleaning	14
Cooling Fan Filter Cleaning	15
Fuse Capacities	15

Specifications

Physical

- Rugged extruded anodised aluminum construction
- Advanced thermal management systems for long LED life
- 0 to 40°C ambient operating temperature
- Available in 279, 546, 1080 and 1613mm lengths
- Yoke, trunion (floor stand), or wall-mount mounting options
- Available in black (standard) or silver (special order)
- See [Dimensions and LEDs, page 2](#)
- See [Fixture Weight, page 9](#)

Electrical

- 100V to 240V 50/60 Hz internal power supply
- Neutrik® PowerCon® input connector
- 1.5m power lead supplied
- Requires power from non-dim source

LEDs

- Luxeon® Rebel™ 2.5W LED emitters (Lustr and Paletta)
- Luxeon K2 3.5W LED emitters (Vivid)
- 50,000 hr. LED life
- See [Note About LED Fixtures, page 2](#)

Optical

- Integral 12° optics (Vivid) and 20° optics (Lustr and Paletta)
- Slots for secondary lenses
- Combine secondary lenses for desired beam spread

Colour

- Seven-colour LED mix for superior colour mixing
- Lustr – Optimised for highest output at white light
- Paletta – Optimised for strong, saturated colours
- Vivid – Optimised for strong, saturated colours at maximum brightness
- Colour rendering as high as 90 CRI
- Interacts seamlessly with conventional sources
- Achieves excellent 3200°K colour or any other Correlated Colour Temperature white light from 800 to 20,000°K
- Beautifully illuminates skin tones and other objects
- Deeply saturated colours across an exceptionally wide gamut

Control

- DMX512-A compliant
- DMX in and thru via 5-pin XLR connectors
- 8-channel (7 colour plus intensity)
- Intensity channel minimizes colour shift during dimming
- Digital LED display for address assignment
- Internal control electronics for smooth low-end dimming at 15-bit resolution
- 21 fixture provides 2 independently controllable cells
- 42 fixture provides 4 independently controllable cells
- 63 fixture provides 6 independently controllable cells

Optional Secondary Lenses

- Beam-spreading lenses available in 10 degree increments from 20 to 80° in horizontal and vertical axis
- Easily interchangeable
- Combine up to 2 secondary lenses at a time

Maximum Power Consumption at Full Intensity

Lustr and Paletta

Model	Watts	Power
11	288	1.25A@230 VAC
21	575	2.5A@230 VAC
42	1150	5.0A@230 VAC
63	1725	7.5A@230 VAC

Vivid

Model	Watts	Power
11	345	1.5A@230 VAC
21	690	3.0A@230 VAC
42	1380	6.0A@230 VAC
63	2070	9.0A@230 VAC

Dimensions and LEDs

Lustr and Vivid

Model	Size in millimeters	Number of LEDs
11	279 x 178 x 178	40
21	546 x 178 x 178	80
42	1080 x 178 x 178	160
63	1613 x 178x 178	240

Paletta

Model	Size in millimeters	Number of LEDs
11	279 x 178 x 127	40
21	546 x 178 x 127	80
42	1080 x 178 x 127	160
63	1613 x 178 x 127	240

Note About LED Fixtures

All LED sources experience some lessening of light output and some colour shift over time. Selador Series fixtures have complex thermal management systems to minimize these changes. With typical usage, a Selador fixture will still achieve 70% of its initial output after 50,000 hours of use. In individual situations, LEDs will be used for different durations and different levels. This can eventually lead to minor alterations in colour performance, necessitating slight adjustment to presets, cues, or programs.

All LEDs exhibit a slight colour shift as their temperature rises from ambient to operating temperature. This may or may not be visible to the eye. If this is a concern, a five to ten minute warm up cue (all colour channels at 100%, intensity channels at 50%) prior to production can minimise this effect.

Overview

Congratulations on your purchase of a *Selador Series by ETC* product.

Selador's x7 Colour System™ seven-hue technology produces a light and colour quality that conventional LED systems cannot duplicate. This unique colour system produces bright, broad-spectrum whites and intense colours equally well, rendering pigments, objects, and skin tones in a natural way.

Each member of the Selador Series product line is unique and optimised for a specific lighting task:

Lustr

- Luxeon Rebel 2.5W LED emitters
- Optimised for the best white light across the entire CCT range
- Beautifully illuminates skin tones and other objects

Paletta

- Luxeon Rebel 2.5W LED emitters
- Optimised for deep, pure pastels and saturated colours
- Interacts seamlessly with conventional sources

Vivid

- Luxeon K2 3.5W LED emitters
- Optimised for deep pastels and strong saturated colours
- High-power LEDs for the longest throws

Information in this manual is applicable to all three *Selador Series by ETC* products unless stated otherwise.

Applications

- Theatres
- Studios
- Churches
- Hotels
- Convention Centers
- Schools

Application	11"	21"	42"	63"
Truss warmer	•			
Front light	•	•		
Side light	•	•		
Key light	•	•		
Fill light	•	•	•	
Specials	•	•		
Downlight	•	•	•	•
Backlight	•	•	•	•
Stagewash	•	•	•	•
Cyc light	•	•	•	•

If you have questions about your Selador series fixture that are not answered in this manual, please contact the supplier of your ETC equipment or ETC Technical Services.

Americas

Electronic Theatre Controls Inc.
 Technical Services Department
 3031 Pleasant View Road
 Middleton, WI 53562
 800-775-4382 (USA, toll-free)
 +1-608 831-4116
service@etcconnect.com

United Kingdom

Electronic Theatre Controls Ltd.
 Technical Services Department
 26-28 Victoria Industrial Estate
 Victoria Road,
 London W3 6UU England
 +44 (0)20 8896 1000
service@etc europe.com

Asia

Electronic Theatre Controls Asia, Ltd.
 Technical Services Department
 Room 1801, 18/F
 Tower 1, Phase 1 Enterprise Square
 9 Sheung Yuet Road
 Kowloon Bay, Kowloon, Hong Kong
 +852 2799 1220
service@etcasia.com

Germany

Electronic Theatre Controls GmbH
 Technical Services Department
 Ohmstrasse 3
 83607 Holzkirchen, Germany
 +49 (80 24) 47 00-0
techserv-hoki@etcconnect.com

Please email comments about this manual to: TechComm@etcconnect.com

Document Conventions

Throughout this manual, the following are used to alert you to notes and safety notices.



Note: *Notes are helpful hints and information that is supplemental to the main text.*



CAUTION: *A Caution statement indicates situations where there may be undefined or unwanted consequences of an action, potential for data loss or an equipment problem.*



WARNING: *A Warning statement indicates situations where damage may occur, people may be harmed, or there are serious or dangerous consequences of an action.*



WARNING: ***RISK OF ELECTRIC SHOCK!** This warning statement indicates situations where there is a risk of electric shock.*

Safety

The Selador series fixtures are intended for professional use only. **Read entire User Manual before using equipment.**

Please note the following safety notices before use:



WARNING: *Note the following safety warnings before use:*

- Do not mount the Selador series fixture on or near a flammable surface.
- Use the fixture in dry locations only, where humidity does not exceed 90 percent (non-condensing). Fixture is not intended for outdoor use.
- Mount and support the fixture only by the primary suspension holes in the enclosure.
- Suspend the fixture from a suitable structure using only the hardware rated for the weight of the fixture.
- In addition to primary suspension, attach a safety cable (ETC Model 400SC or other approved safety cable or device) to the fixture housing. Appropriate attachment points (holes) are provided in the protruding tabs on either end of the fixture housing.
- Disconnect the unit from power and from DMX before all cleaning and maintenance.
- Maximum ambient temperature: $T_a=40^{\circ}\text{C}$
- Maximum exterior surface temperature: $T_{\text{max}}=80^{\circ}\text{C}$

Installation

Power and Data Cabling Requirements

Power

The Selador series fixture operates on AC power, 100 to 240VAC/50-60Hz. You may use a circuit powered through an SCR dimmer, as long as the dimmer is set to unregulated non-dim (switched) operation.

Power is supplied through a standard 1.5m power-input cable with Neutrik PowerCon locking pigtail with bare ends for attachment of your desired connector.

Data

The Selador series fixtures operate on a DMX control signal. The unit is supplied with a 5-pin XLR DMX input connector and a 5-pin DMX Thru connector. DMX cables should be acceptable for DMX data transmission (not microphone cable) and should follow the standard pinout. The optional secondary data pair is not used by the Selador series fixtures. The maximum DMX data run from any DMX source to the last fixture in a chain is 300m. Termination is required in the data-out port of the last fixture in each data chain.

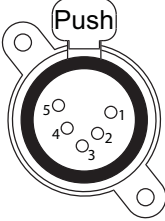
DMX512 pinout for five-pin XLR female		
	1	Common (Shield)
	2	Data -
	3	Data +
	4	not connected
	5	not connected

See [Control, page 12](#) for additional information on DMX addressing of Selador Series fixtures.

Installation Procedures

Installing Mounting Hardware

Three different options are provided for mounting Selador fixtures.

- Yoke for 11 and 21 units
- Floor trunnions for all fixtures
- Pipe hanging brackets for all fixtures



Note: *Trunnions should be installed with the feet inward so that fixtures can be lined up end to end if needed.*

Installation Clearances

High-ambient Environments

In environments of higher ambient temperatures 35-40°C Selador Series fixtures should be operated at no more than 80% of maximum output. Note that the vast majority of colour mixes involve more than one colour channel at less than 100% intensity, so this may not be an issue during day-to-day use.

However, in high-ambient conditions avoid turning all channels to 100% for channel checks or focusing. Doing so may cause the power supply to shut down. Following a cool down period, the power supply will automatically reset and the fixture will return to operation.



CAUTION: *Duty Cycle*

Selador Series fixtures use ultra-quiet fans to cool the components and provide quiet predictable service for extended periods of time. When not in use, fixtures should be powered down (disconnected from power either at the breaker or by unplugging) to avoid unnecessary wear on the fan.

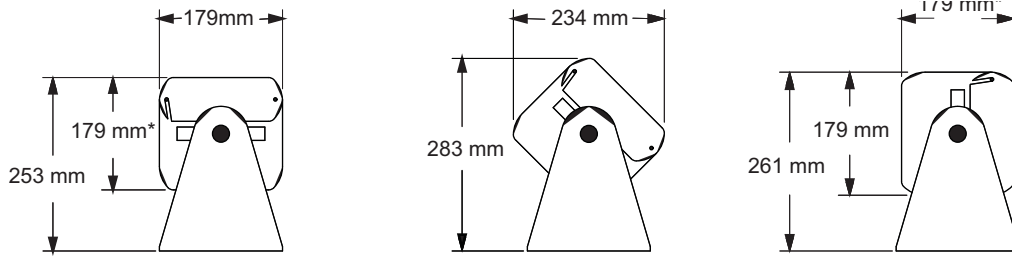

Floor trunnion dimensions

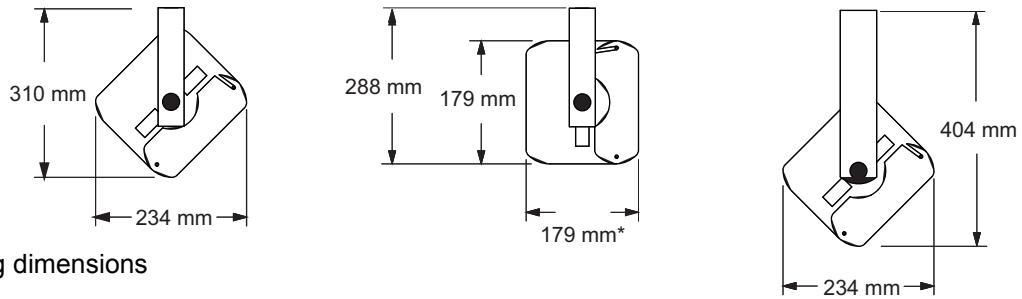

Hanging dimensions

* = Paletta fixtures have a depth dimension of 153mm.

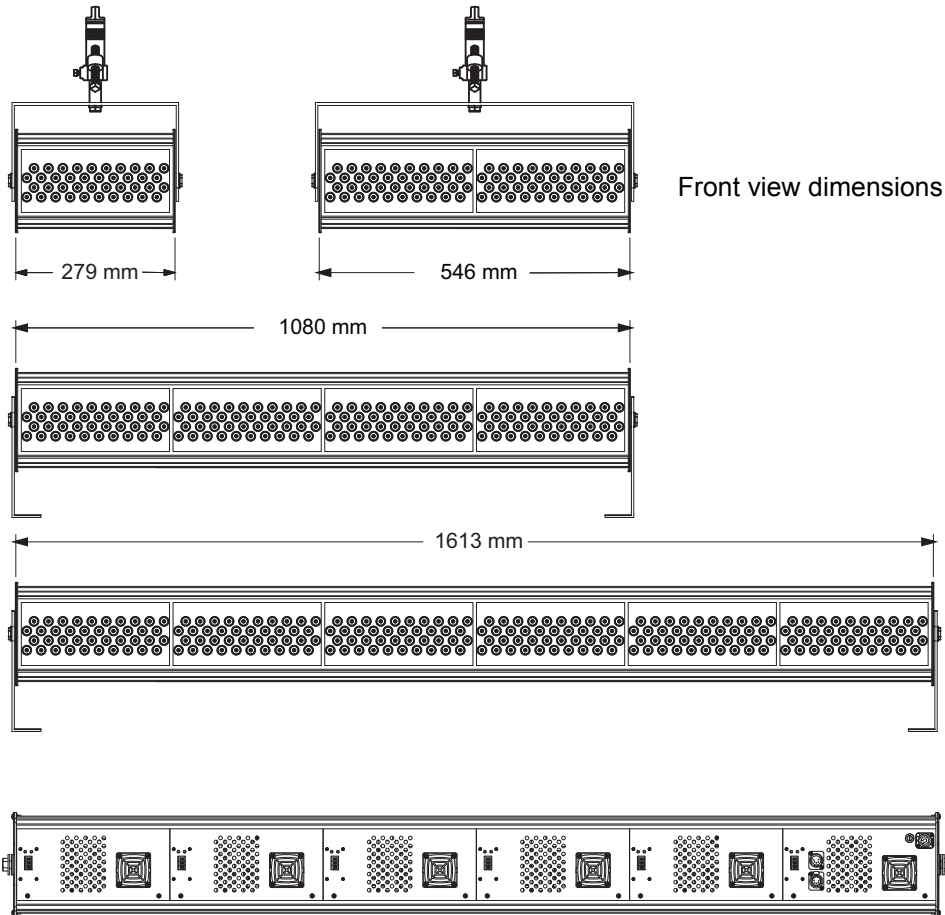

Front view dimensions

Rear view to show power, data connections, and repeating addressing and fan locations

Safety Cable

The safety cable (or other approved safety device) should be attached to the fixture housing and wrapped around the hanging structure (pipe). Appropriate attachment points (holes) are provided in the protruding tabs on either end of the fixture housing. Take care to leave as little slack as possible in the safety cable to avoid the cable catching the yoke of the fixture.

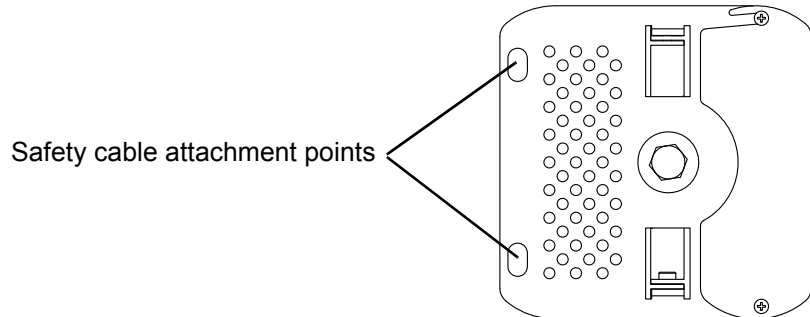

Fixture Weight

Total weight depends on how the individual fixture is configured. Weights shown do not include secondary lenses.

Lustr and Vivid

Model	Weight ^a	Shipping Weight
	Kg.	Kg.
11	5.2	6.9
21	9.1	11.4
42	15.9	19.1
63	24.1	28.2

a) Does not include mounting hardware.

Paletta

Model	Weight ^a	Shipping Weight
	Kg.	Kg.
11	4.7	6.4
21	8.2	10.5
42	14.6	17.7
63	22.1	26.4

a) Does not include mounting hardware.

Installing Secondary Lenses

Up to two secondary lenses can be installed in the slots towards the front of the fixture. The stacking order and distance from the LED array are not important to the function of the lenses. To avoid lenses being too loose and potentially overlapping each other, use the narrower slots for thinner lenses.

To install secondary lenses:

Step 1: Loosen the screw on the end of the access panel that has the slot in it.

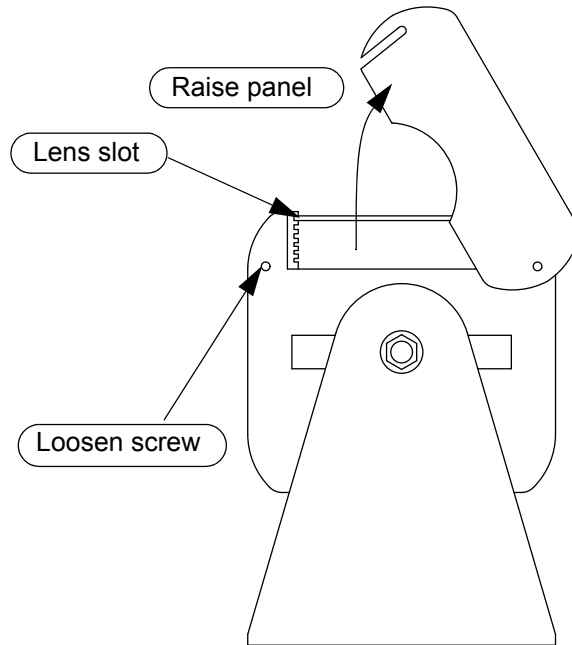

Step 2: Raise the panel out of the way, but leave it attached to the fixture.

Step 3: Slide the secondary lenses into the slots above the LEDs.

Step 4: Lower the panel and tighten the screw.

Connections and Addressing

Connect AC input power and DMX data cables to the appropriate ports as shown below.

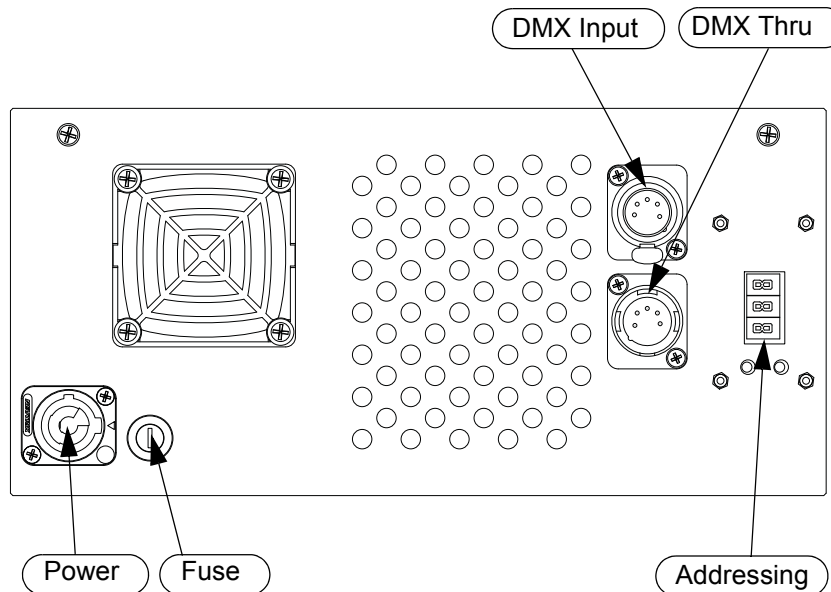

Connect the incoming DMX data cable to the DMX Input connector. If you are daisy-chaining the data to other fixtures or DMX-controlled devices, connect the next DMX cable to the DMX Thru connector. The Selador Series fixtures require that the last fixture on a DMX line be terminated with a 120Ω resistor between pins 2 and 3.

Connect the AC Input cable:

Align and insert the power connector. Twist the connector clockwise until it locks into place.

Disconnect the AC Input cable:

Slide back the locking tab, twist the connector counterclockwise and pull to unlock and disconnect the power connector.

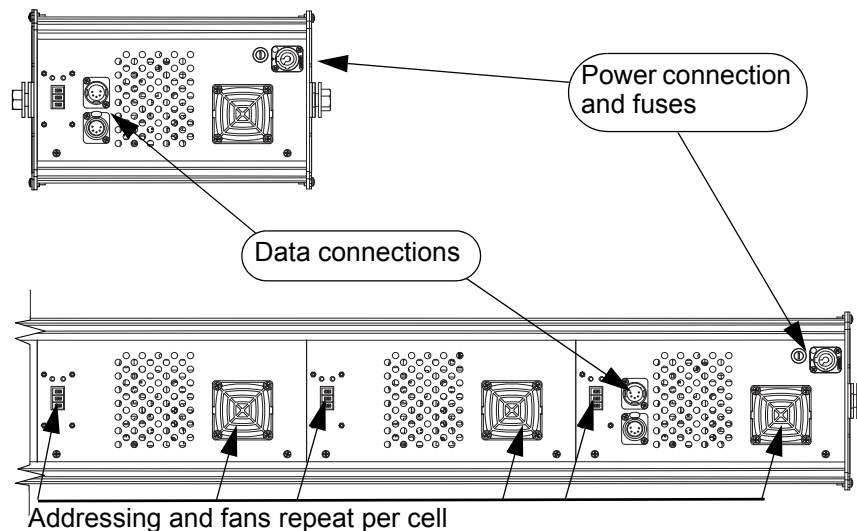

Fuse

The quarter-turn fuse-holder requires a straight blade screwdriver to remove and reinstall a fuse. Refer to [Fuse Capacities, page 15](#) for information about fuse types.

Control

Use the two push buttons on the bottom of the fixture to set the starting address for the fixture. View the LED display with the push buttons on the left. The top push button increases the number and the bottom push button decreases the number. Pressing and holding the push button increases the rate of change. **When fixtures are powered up, they may temporarily respond to DMX address 001 for the first few seconds of operation.** New address settings take effect after the LED display turns off.



CAUTION: *Do not push the up and down address buttons simultaneously, or internal fixture software settings can be inadvertently compromised and performance affected.*

Up and down address buttons are recessed to avoid inadvertent address changes. Use a Phillips screwdriver or other blunt device to lightly push the switches. To avoid damaging the switches, do not use sharp objects or excessive force when changing fixture address.

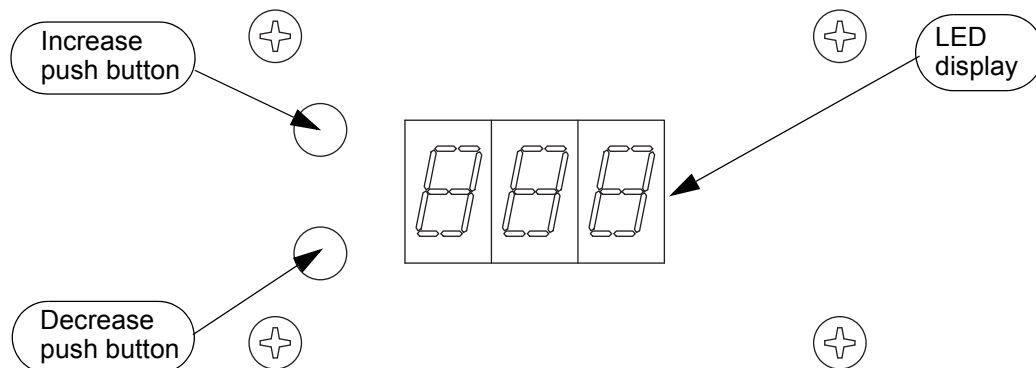

Addresses must be set between 1 and 505. Selador fixtures are manufactured based on an 11" LED array, or cell. Each cell can be addressed individually. Eleven inch fixtures have one cell, 21" fixtures have two cells, 42" fixtures have four cells, and 63" fixtures have six cells. A 42" fixture can be addressed as four individual cells, one cell, or any combination.

Each Selador fixture must be considered a separate DMX device for the purpose of DMX line-loading calculations, with the exception of 63" fixtures. These 63" fixtures must each be considered 1.5 DMX devices for line loading.

Fixture	Number of Cells	Number of DMX Devices
11	1	1
21	2	1
42	4	1
63	6	1.5

DMX line-loading practice dictates that no more than 31 devices can be daisy-chained together. Consequently, no combination of Selador fixtures totaling more than 31 DMX devices should be configured in one DMX line. For example, twenty 6-cell units (30 DMX devices) are okay. Twenty-one 6-cell units (31.5 DMX devices) are not acceptable. For runs of fixtures totaling more than 31 DMX devices, split the DMX runs by using a DMX splitter.



Note: *A fixture with a starting address higher than 505 will not have control of all parameters. Therefore, 505 is the highest address shown on the address display.*

Each cell of a Selador Series fixture occupies eight DMX channels. Seven are individual colours and the eighth is the master intensity. The table below describes the order and function of each address.

	Data Channel	Colour	Value	Function
1	Fixture address	Red	0-255	Intensity 0-100%
2	Fixture address + 1	Red-orange	0-255	Intensity 0-100%
3	Fixture address + 2	Amber	0-255	Intensity 0-100%
4	Fixture address + 3	Green	0-255	Intensity 0-100%
5	Fixture address + 4	Cyan	0-255	Intensity 0-100%
6	Fixture address + 5	Blue	0-255	Intensity 0-100%
7	Fixture address + 6	Indigo	0-255	Intensity 0-100%
8	Fixture address + 7	Master intensity control	0-255	Overall intensity 0-100%



Note: Use individual colour channels to create colour mix. Use Master Intensity Control to set fixture intensity. Master Intensity Control (Channel 8) must be above 0% for the fixture to output.

Colour Matching

This information will be provided in a future release of this manual.

Routine Maintenance

General Fixture Cleaning

To ensure optimum performance of your Selador series fixture, you should perform the following inspections and cleanings at least once a year. You may need to inspect or clean the fixture more often, depending on the type and amount of use your fixture experiences during the year.



CAUTION: *Allow fixture to cool down completely prior to cleaning.*

Disconnect all power and DMX cables prior to cleaning.

Check for excessive dust or debris in the heat-dissipating fins around the entire fixture enclosure. Clean using compressed air or a soft cloth. Keeping the heat sink components of the enclosure clean facilitates efficient cooling and extends LED longevity.

NEVER spray liquids into the fixture.

NEVER spray compressed air into a fixture that is powered-up.

- A can of compressed air or oil-free air from an air compressor set at a low setting can be used to blow through the vent holes and remove dust or other debris from the interior of the fixture. Dust build-up can cause overheating and premature shutdown.
- Remove the secondary lenses (if used) and clean out any dust and debris. All components, including the secondary lenses, can be cleaned using compressed, oil-free air as described above or a clean micro-fiber cloth. The use of any liquid cleaning solution is not recommended for Selador fixtures.
- Inspect all mounting hardware for wear and, if necessary, clean using compressed, oil-free air or a soft, lint-free cloth.

Cooling Fan Filter Cleaning

- ❑ Cooling fan filters should be inspected at a minimum every six months; more frequently if fixtures are powered on for more than four hours per day
- ❑ Use a vacuum cleaner to remove dust from each fan filter
- ❑ In dusty environments or conditions involving the use of smoke machines, clean the filters as follows:
 - Using fingernail or small flat-blade screwdriver, remove fan filter cover by prying under one of the two locking tabs
 - Carefully remove foam fan filter from fan assembly
 - Gently wash foam fan filter in a solution of mild dishwashing solution and water
 - Thoroughly rinse each foam fan filter in clear water
 - Pat dry or air-dry filters
 - After filters are completely dry, reinstall by inserting them into fan assembly
 - Reattach the filters to the fixture



Note: *No user-serviceable parts are inside.*

Fuse Capacities

All Selador Fixtures use 3AG 250V 32mm x 6mm fuses. Use the following capacity fuses for all Selador fixtures; Lustr, Paletta, and Vivid.

Fixture Size	Fuse Value
11	2 A
21	4 A
42	8 A
63	10 A



Corporate Headquarters ■ 3031 Pleasant View Road, P.O. Box 620979, Middleton, Wisconsin 53562-0979 USA ■ Tel +608 831 4116 ■ Fax +608 836 1736
London, UK ■ Unit 26-28, Victoria Industrial Estate, Victoria Road, London W3 6UU, UK ■ Tel +44 (0)20 8896 1000 ■ Fax +44 (0)20 8896 2000
Rome, IT ■ Via Ennio Quirino Visconti, 11, 00193 Rome, Italy ■ Tel +39 (06) 32 111 683 ■ Fax +39 (06) 32 656 990
Holzkirchen, DE ■ Ohmstrasse 3, 83607 Holzkirchen, Germany ■ Tel +49 (80 24) 47 00-0 ■ Fax +49 (80 24) 47 00-3 00
Hong Kong ■ Rm 1801, 18/F, Tower 1 Phase 1, Enterprise Square, 9 Sheung Yuet Road, Kowloon Bay, Kowloon, Hong Kong ■ Tel +852 2799 1220 ■ Fax +852 2799 9325
Service: (Americas) service@etconnect.com ■ (UK) service@etceurope.com ■ (DE) techserv-hoki@etconnect.com ■ (Asia) service@etcasia.com
Web: www.etconnect.com ■ Copyright © 2009 ETC. All Rights Reserved. ■ Product information and specifications subject to change.
7401M1210 ■ Rev A ■ Released 2009-07