

# SmartBar™ & SmartModule™

---

## CE User Manual

Version 1.42



Copyright © Electronic Theatre Controls, Inc.  
All Rights reserved.  
Product information and specifications subject to change.  
Part Number: **7521M1200-1.42-GB** Rev A  
Released: July 2005

# Table of Contents

---

	<b>Introduction</b> . . . . .	<b>1</b>
	SmartBar/SmartModule Models & Features . . . . .	1
	Using this Manual . . . . .	3
	Help from ETC Technical Services . . . . .	3
<b>Section 1:</b>	<b>Unpacking &amp; Setup</b> . . . . .	<b>4</b>
	Unpacking & Checking . . . . .	4
	Positioning . . . . .	4
	Connections . . . . .	4
	Power Input Connections . . . . .	4
	Power Output Connections . . . . .	5
	Convenience Outlet (SmartBar Only) . . . . .	5
	DMX Data Signal Connections . . . . .	5
	Safety . . . . .	5
<b>Section 2:</b>	<b>Control Panel Layout</b> . . . . .	<b>6</b>
<b>Section 3:</b>	<b>Function Overview</b> . . . . .	<b>7</b>
	Maximum and Minimum Levels . . . . .	7
	Response Speed . . . . .	7
	Non-dim Operation . . . . .	7
	Local Control . . . . .	7
	Dimmer Curves . . . . .	7
	Status Reporting . . . . .	8
	Backup Settings . . . . .	8
<b>Section 4:</b>	<b>Information Displays &amp; Manual Control</b> . . . . .	<b>8</b>
	Check Dimmer Information . . . . .	8
	Check Set Dimmer Mains Voltage & Frequency . . . . .	8
	Check Dimmer Software Version . . . . .	9
	Manually Control a Dimmer Level . . . . .	9
	Operate the Chaser . . . . .	9
<b>Section 5:</b>	<b>Programming</b> . . . . .	<b>10</b>
	Flow Diagram . . . . .	10
	General Programming Advice . . . . .	10
	Passwords . . . . .	10
	Navigation Through the Menus . . . . .	10
	Channel Characteristics . . . . .	10
	Front Panel Controls . . . . .	11
	General controls . . . . .	11
	Change the Dimmer Characteristic Setup Scheme . . . . .	11
	DMX programming . . . . .	12
	Set the DMX Addressing Scheme . . . . .	12

---

ETC®, Emphasis®, Unison®, Light Manager™, Obsession® II, ETCNet2™, and EDMX™, SmartBar™, SmartModule™ are either registered trademarks or trademarks of Electronic Theatre Controls, Inc. in the United States and other countries. All other trademarks, both marked and not marked, are the property of their respective owners.

---

	Set the DMX Addresses . . . . .	12
	Set the DMX Backup Condition . . . . .	13
	Set the DMX Backup Preset. . . . .	13
	Set the DMX Minimum Reset . . . . .	13
	Set the Serial Address . . . . .	14
	Set the Serial Address . . . . .	14
	Maximum & Minimum levels . . . . .	14
	Set Max. & Min. Levels. . . . .	14
	Response time . . . . .	15
	Set Dimmer Response Times. . . . .	15
	Dimmer Curves . . . . .	16
	Set a Dimmer Curve . . . . .	16
	Start Mode. . . . .	17
	Set Start Mode . . . . .	17
	Passwords. . . . .	17
	Setup Passwords . . . . .	18
	Sleep mode. . . . .	18
	Set the dimmer rack to 'Sleep' mode . . . . .	18
	Fault reporting . . . . .	19
	Check Error Messages & Reset the Log . . . . .	19
	Restore Factory Defaults . . . . .	19
	Reset to Factory Default Settings. . . . .	19
<b>Section 6:</b>	<b>DimSTAT . . . . .</b>	<b>20</b>
<b>Section 7:</b>	<b>Faults &amp; Troubleshooting . . . . .</b>	<b>21</b>
	Reported Faults. . . . .	21
	Over Temperature . . . . .	21
	No Load (control present but no output) [SmartModule Only] . . . . .	21
	First Line Troubleshooting. . . . .	21
	LCD Display Blank . . . . .	21
	No Output from One Channel. . . . .	21
	Breaker Trips Continuously . . . . .	21
	Dimmer Output is Stuck On Full . . . . .	21
<b>Appendix A:</b>	<b>Specifications . . . . .</b>	<b>23</b>
	SmartBar Control Features . . . . .	23
	SmartBar Specification . . . . .	23
	General. . . . .	23
	Physical . . . . .	24
	Mechanical . . . . .	24
	Electrical. . . . .	24
	SmartModule Specification . . . . .	25
	General. . . . .	25
	Physical . . . . .	25
	Mechanical . . . . .	25
	Electrical. . . . .	25
<b>Appendix B:</b>	<b>Menu Layout . . . . .</b>	<b>27</b>

# Introduction

## SmartBar™ & SmartModule™ Models & Features

The SmartBar and SmartModule products differ in physical likeness but function very similarly and share the same user interface style. Both are a fully digital triac dimmers with fuse or circuit breaker overcurrent protection per circuit.

The control panel includes a backlit menu-driven LCD screen to set and review operational parameters, performance and status information. SmartBar/SmartModule units include many advanced features including DimSTAT, the bi-directional network used for status and circuit fault analysis, remote programming, and software updates via the DMX connector. Reference [“DimSTAT” on page 20](#) of this document.

This manual describes the operation and programming of the SmartBar and SmartModule dimming products. The models covered in this manual include:

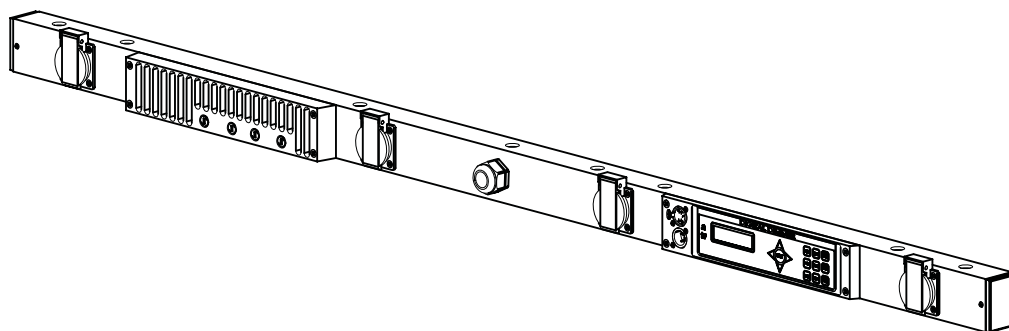

SmartBar Dimmers			
Description	Part Number	Amperage/Feed	Load Protection
<b>Single phase 6A - 230V/240V - 1200mm - Convenience Outlet</b>			
SmartBar 1200mm 4 x 1.25kW, CE17	7500A1-2401-C	25A, 3m cable 3 x 2.5mm <sup>2</sup> w. bare ends	Fuses
SmartBar 1200mm 4 x 1.25kW, SCHUKO	7500A1-2401-S	25A, 3m cable 3 x 2.5mm <sup>2</sup> w. bare ends	Fuses
SmartBar 1200mm 4 x 1.25kW, NF French	7500A1-2401-F	25A, 3m cable 3 x 2.5mm <sup>2</sup> w. bare ends	Fuses
SmartBar 1200mm 4 x 1.25kW, UK 13A	7500A1-2401-U13	25A, 3m cable 3 x 2.5mm <sup>2</sup> w. bare ends	Fuses
SmartBar 1200mm 4 x 1.25kW, UK 15A Round Pin	7500A1-2401-U15	25A, 3m cable 3 x 2.5mm <sup>2</sup> w. bare ends	Fuses
<b>Single phase 6A - 230V/240V - 1500mm</b>			
SmartBar 1500mm 4 x 1.25kW, CE17	7500A1-9510-C	25A, 3m cable 3 x 2.5mm <sup>2</sup> w. bare ends	Fuses
SmartBar 1500mm 4 x 1.25kW, SCHUKO	7500A1-9510-S	25A, 3m cable 3 x 2.5mm <sup>2</sup> w. bare ends	Fuses
SmartBar 1500mm 4 x 1.25kW, NF French	7500A1-9510-F	25A, 3m cable 3 x 2.5mm <sup>2</sup> w. bare ends	Fuses
SmartBar 1500mm 4 x 1.25kW, UK 13A	7500A1-9510-U13	25A, 3m cable 3 x 2.5mm <sup>2</sup> w. bare ends	Fuses
SmartBar 1500mm 4 x 1.25kW, UK 15A Round Pin	7500A1-9510-U15	25A, 3m cable 3 x 2.5mm <sup>2</sup> w. bare ends	Fuses
<b>3 phase 6A - 230V/240V - 2200mm - HAN 6HSB Input - Female HAN connector included</b>			
SmartBar 2200mm, 6 x 1.25kW, CE17	7500A1-9909-C	Harting 35A 6-pole chassis connector	Fuses
SmartBar 2200mm, 6 x 1.25kW, SCHUKO	7500A1-9909-S	Harting 35A 6-pole chassis connector	Fuses
SmartBar 2200mm, 6 x 1.25kW, NF French	7500A1-9909-F	Harting 35A 6-pole chassis connector	Fuses

SmartBar Dimmers (Continued)			
Description	Part Number	Amperage/Feed	Load Protection
<b>3 phase 10A - 230V/240V - 2200mm - HAN 6HSB Input - Female HAN connector included</b>			
SmartBar 2200mm, 6 x 2.3kW, CE17	7500A1-9709-C	Harting 35A 6-pole chassis connector	Fuses
SmartBar 2200mm, 6 x 2.3kW, SCHUKO	7500A1-9709-S	Harting 35A 6-pole chassis connector	Fuses
SmartBar 2200mm, 6 x 2.3kW, NF French	7500A1-9709-F	Harting 35A 6-pole chassis connector	Fuses
SmartBar 2200mm, 6 x 2.3kW, Swiss	7500A1-9709-CH	Harting 35A 6-pole chassis connector	Fuses
<b>3 phase 10A - 230V/240V - 2230mm - Convenience Outlet - HAN 6HSB Input - Female HAN connector included</b>			
SmartBar 2230mm, 6 x 2.3kW, CE17	7500A1-9709M-C	Harting 35A 6-pole chassis connector	Breakers
SmartBar 2230mm, 6 x 2.3kW, SCHUKO	7500A1-9709M-S	Harting 35A 6-pole chassis connector	Breakers
SmartBar 2230mm, 6 x 2.3kW, NF French	7500A1-9709M-F	Harting 35A 6-pole chassis connector	Breakers
SmartBar 2230mm, 6 x 2.3kW, Swiss	7500A1-9709M-S	Harting 35A 6-pole chassis connector	Breakers
SmartBar 2230mm, 6 x 2.3kW, UK 15A Round Pin	7500A1-9709M-U15	Harting 35A 6-pole chassis connector	Breakers

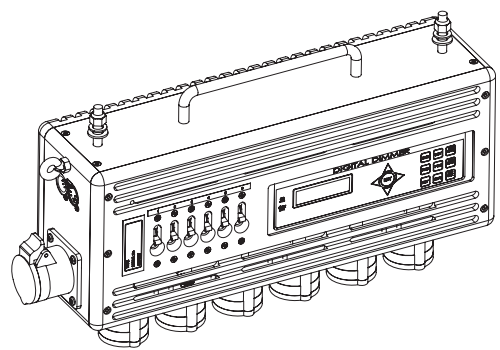

SmartModule Dimmers			
Description	Part Number	Amperage/Feed	Load Protection
<b>Single phase 230 V</b>			
SmartModule 4 x 6A, CE17	7520A1-9724-C	25A, 3m cable 3 x 2.5mm <sup>2</sup> w. bare ends	Fuses
SmartModule 4 x 6A, SCHUKO	7520A1-9724-S	25A, 3m cable 3 x 2.5mm <sup>2</sup> w. bare ends	Fuses
SmartModule 4 x 6A, NF French	7520A1-9724-F	25A, 3m cable 3 x 2.5mm <sup>2</sup> w. bare ends	Fuses
SmartModule 4 x 6A, UK 15A Round Pin	7520A1-9724-U15	25A, 3m cable 3 x 2.5mm <sup>2</sup> w. bare ends	Fuses
SmartModule 6 x 10A, UK 13A	7520A1-9810-U13	60A, Harting 35A 6-pole chassis connector	Breakers
SmartModule 6 x 10A, UK 15A Round Pin	7520A1-9810-U15	60A, Harting 35A 6-pole chassis connector	Breakers
<b>3 phase 3PNE</b>			
SmartModule 6 x 10A, CE17	7520A1-9810-C	20A, CE32 chassis connector	Breakers
SmartModule 6 x 10A, SCHUKO	7520A1-9810-S	20A, CE32 chassis connector	Breakers
SmartModule 6 x 10A, Dual NF French	7520A1-9810-C	20A, CE32 chassis connector	Breakers
SmartModule 6 x 10A, Dual Schuko for Delta Supply	7520A1-9810-SD	20A, CE32 chassis connector	Breakers
SmartModule 6 x 10A, CE17 for Delta Supply	7520A1-9810-CD	20A, CE32 chassis connector	Breakers

## Using this Manual

Due to the similarities of user interface and function of both the SmartBar and SmartModule, this manual references both products where common features exist.

In order to be specific about where features and commands are found, the following naming and text conventions will be used throughout this manual:

- Buttons and screen display items are indicated in **bold text**. For example: Press **INFO**. Choose **CHANNEL INFO** menu.
- References to other parts of the quick guide are indicated in *italics*. When viewing this quick guide electronically, click on the reference to jump to that section in the document.



---

**Note:** *Notes are helpful hints and information that is supplemental to the main text.*

---



---

**CAUTION:** *Caution statement indicates situations where there may be undefined or unwanted consequences of an action, potential for data loss or an equipment problem.*

---



---

**WARNING:** *A Warning statement indicates situations where damage may occur, people may be harmed, or there are serious or dangerous consequences of an action.*

---

Please email comments about this manual to: [TechComm@etconnect.com](mailto:TechComm@etconnect.com)

## Help from ETC Technical Services

If you are having difficulties, your most convenient resources are provided in this user manual. To search more widely, try the ETC website at [www.etconnect.com](http://www.etconnect.com). If none of these resources is sufficient, contact ETC Technical Services directly at one of the offices identified below.

### Americas

Electronic Theatre Controls Inc.  
Technical Services Department  
3031 Pleasant View Road  
Middleton, WI 53562  
800-775-4382 (USA, toll-free)  
+1-608 831-4116  
[service@etconnect.com](mailto:service@etconnect.com)

### United Kingdom

Electronic Theatre Controls Ltd.  
Technical Services Department  
5 Victoria Industrial Estate  
Victoria Road,  
London W3 6UU England  
+44 (0)20 8896 1000  
[service@etceurope.com](mailto:service@etceurope.com)

### Asia

Electronic Theatre Controls Asia, Ltd.  
Technical Services Department  
Room 605-606  
Tower III, Enterprise Square  
9 Sheung Yuet Road  
Kowloon Bay, Kowloon, Hong Kong  
+852 2799 1220  
[service@etcasia.com](mailto:service@etcasia.com)

### Germany

Electronic Theatre Controls GmbH  
Technical Services Department  
Ohmstrasse 3  
83607 Holzkirchen, Germany  
+49 (80 24) 47 00-0  
[techserv-hoki@etconnect.com](mailto:techserv-hoki@etconnect.com)

# Section 1: Unpacking & Setup

## Unpacking & Checking

SmartBar/SmartModule dimmer units are a self-contained dimming system and only require a suitable mains input. See "[Power Input Connections](#)" below.

The SmartBar/SmartModule is packaged to withstand normal transportation, but before operating the unit, check there is no sign of transit damage which could affect the operation and safety of the dimmer.

## Positioning

The SmartBar/SmartModule is an extremely versatile dimmer, and can be incorporated in catwalks, nearby the lights, or used as a portable dimmer. It is designed for natural ventilation cooling. Care must be taken to ensure adequate ventilation especially when the dimmers are installed into an area with a high ambient temperature. For added convenience the SmartBar is supplied with mounting hardware suitable for hanging fixtures.

## Connections



**Note:** *All electrical connections to the SmartBar/SmartModule must be made by a suitably-qualified person.*

### Power Input Connections

Input power is supplied via single or 3-phase supply depending on the dimmer model purchased. Reference "[Introduction](#)" on [page 1](#) for a listing.

All SmartBar/SmartModules with Harting type input connector will be supplied with a female cable connector in the box.

The 4-channel 1.25kW SmartBar or SmartModule units are supplied with a 3m bare end flexible cable and requires a suitable input connector, not supplied by ETC. The Harting input connector should meet the following specifications depending on the model of dimmer supplied. Reference "[Introduction](#)" on [page 1](#) for detailed requirements of the unit purchased.

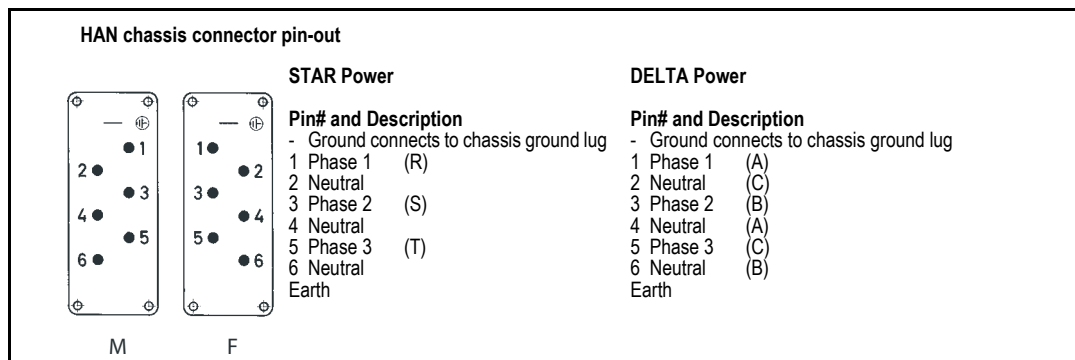

## Power Output Connections

The SmartBar/SmartModule include a choice of SCHUKO, CE17, NF French, UK 13A, UK 15A Round Pin, and Swiss per channel. Connections to the loads are simply made by fitting the appropriate plug to the load cable.



**Note:**

*Each SmartBar (SB4-6 model only) output is protected by a fuse which is 5x20mm ceramic fast blow 6.3A @ 250V. For replacements please contact ETC Technical Services and request ETC part number F245.*

---

## Convenience Outlet (SmartBar Only)

A single auxiliary outlet is located centrally on the bar.

## DMX Data Signal Connections

The dimmers are controlled using DMX 512. This is connected by a two-pair and shield high-speed data cable with XLR 5-pin connectors (male = input; female = output).

Pin connections are:

- 1 Shield
- 2 DMX -
- 3 DMX +
- 4 DimSTAT - (optional)
- 5 DimSTAT + (optional)

The DMX network supports up to 32 SmartBar/SmartModules (192 dimmers in total) connected to each DMX line. For larger installations where more DMX lines are required, the use of a DMX splitter is recommended. Any splitter used has to accommodate bi-directional data on pins 4 and 5 for DimSTAT to operate.



**Note:**

*If utilizing DimSTAT, please reference [“DimSTAT” on page 20](#) for details of operation.*

Termination is required for both DMX and DimSTAT data on all networks. The last DMX output socket in the line has to be terminated with two 120Ω 1/4 Watt resistors connected between pins 2 and 3 (DMX) and between 4 and 5 (DimSTAT). A 'dummy plug' XLR male connector with the termination resistors fitted is recommended for this purpose.



**Note:**

*If a DimSTAT communications network is not required, the DMX cable specification may be reduced to a single pair.*

---

## Safety

Do not use the dimmer if the mains input cable has been damaged or the body of the case is not intact.

## Section 2: Control Panel Layout

---

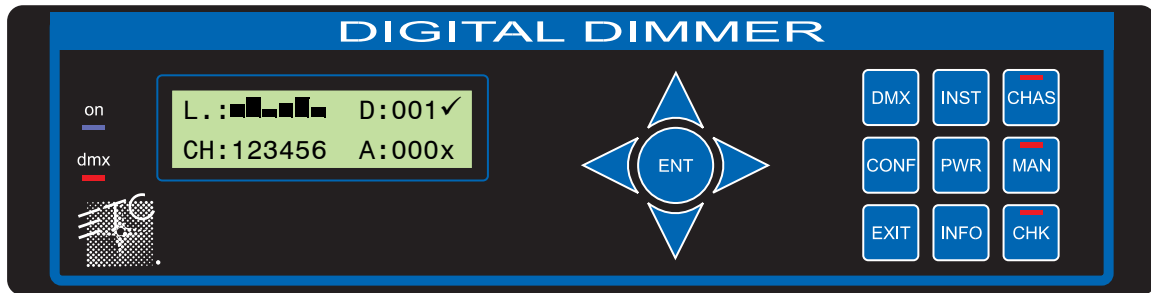

**ON LED:** Illuminates blue when power is applied.

**DMX LED:** Illuminates red continuously when valid DMX is present. LED flashes when there is no DMX signal.

**ENT & cursor arrows:** ENT (ENTer) completes a programming step and records the information in the memory. The four cursor arrows provide navigation through the set-up menu, and the means to enter data.

- ↑: Up cursor. Higher level menu feature or move cursor up in display screen or number increment.
- ↓: Down cursor. Lower level menu feature or move cursor down in display screen or number decrement
- ←: Left cursor. Move cursor left in display screen
- : Right cursor. Move cursor right in display screen

**DMX :** Selects DMX address per channel when the single mode is selected, or the first address of the group when the joined mode is selected.

**INST :** Install function. To set-up dimmer functionality during installation with options as follows:

- DMX configuration (individual or combined)
- Channel configuration (individual or combined)
- Channel information
- Password set-up
- Dimmer hardware configuration
- Minimum level reset (preheat off when DMX is not present)
- Factory reset
- Sleep mode
- DMX backup levels
- DMX failure options

**CHAS (with LED):** Chase. Provides set-up for the dimmer's internal chase system for stand-alone display effects. The LED illuminates when the dimmer is in the 'chase mode.

**CONF:** Configure. Access to a sub-menu to set the detailed configuration for individual or combined dimmer channels. Options available are:

**MAX:** Maximum. Sets the maximum output level from 30% to 100%,

- individually or combined.
- MIN:** Minimum. Sets the minimum output level from 0% to 29.9%, individually or combined.
- T-IN:** Response time to fade in from 0.00 secs to 99.99 secs.
- T-OUT:** Response time to fade out from 0.00 secs to 99.99 secs.
- CURVE:** Dimmer law selection
- I/O:** Non-dim On/off operation
- PRIORITY:** Sets the channels not effected by the current limit mode in DimSTAT
- MODE:** Start mode (initiated after 5 minutes off) normal, soft start, burst, proportional.
- MAN:** Manual. Provides manual control of each channel for circuit testing and pre-setting.
- EXIT:** Returns to the opening screen menu option without recording changes.
- INFO:** Information. Provides a display of the nominal supply voltage and installed software version.
- CHK (with LED):** Check. Displays a log of any circuit or dimmer faults. LED illuminates if an error occurs.
- PWR:** Power. This function is not available in this product line.

## Section 3: Function Overview

---

### Maximum and Minimum Levels

The maximum output of the dimmer may be adjusted to improve lamp life or to limit the power used. A minimum level (preheat) may be necessary with some filaments to improve the speed of fast flashes or chases. A 'Minimum level reset' option exists (INST>General settings menu) to switch off the preheat when the DMX signal is not present (i.e. when the control desk is switched off).

### Response Speed

The time taken for a dimmer to 'fade' to the applied control signal level is used to control the rate of change of current to the filament and improve lamp life for higher wattage filaments.

### Non-dim Operation

Each dimmer may be selected to operate as a dimmer, or as a non-dim switch. The programmed time of T-IN becomes the minimum on-time, T-OUT now has the function of minimum off-time.

### Local Control

SmartBar/SmartModule have a range of integrated control facilities for basic operation without a control desk. These include live manual control of each dimmer level, preset recorded levels for fixed display lighting, and an integral chaser with 20 preset chase patterns and variable speed and level.

## Dimmer Curves

A selection of dimmer curve transfer functions (the relationship between from control signal level and dimmer output) are available to compensate for the different visual responses of a live audience or a TV camera, and to provide improved dimming for non-resistive loads such as fluorescent tubes.

## Status Reporting

All SmartBar and SmartModule dimmers incorporate a bi-directional communications system called DimSTAT which provides feedback of the dimmer status and fault reporting to a PC. DimSTAT also enables a remote PC to control any dimmer in the network, and to update the dimmer's internal operating software and preset options. DimSTAT network software and a remote PC are optional extras

## Backup Settings

Should the DMX signal fail, the SmartBar/SmartModule can be programmed to hold the present level, fade to zero or fade to a pre-programmed backup level.

# Section 4: Information Displays & Manual Control

---

The following group of buttons provides direct access to detailed set-up and status information and manual override controls.

### Check Dimmer Information

- Step 1: Press **INST**.
- Step 2: Use **↑** or **↓** to choose **CHANNEL INFO** menu.
- Step 3: Press **ENT**.

- The screen displays:

INFO	CH: [ 1 ]
TEMP.	84 ' F 29 ' C

- Step 4: Press **←** or **→** to select other information as follows:

- TEMPERATURE:** Internal temperature
- DMX:** DMX level received
- ACTUAL:** the level the dimmer is responding to (may differ from DMX value due to MIN, MAX or MAN influence).
- STATUS:** error message(s) with details.

- Step 5: Use **↑** or **↓** to select another dimmer channel (shown in square brackets), or,
- Step 6: Press **EXIT** to leave the screen.

### Check Set Dimmer Mains Voltage & Frequency

- Step 1: Press **INFO**.

- The screen displays:

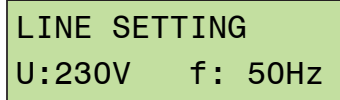

- After 3 seconds, the screen automatically changes to show the next Info screen (Version).

### Check Dimmer Software Version

Step 1: Press **INFO** twice.

- The screen displays:

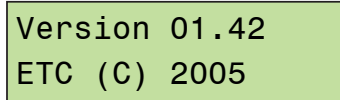

- After 3 seconds, the screen automatically resets to show the normal output details.

### Manually Control a Dimmer Level

You can control any dimmer directly from the front panel using the cursor controls to set the desired level. This can be used for testing circuits, overriding control signals or setting an independent fixed level. The level is mixed with any other incoming signal on a highest level takes precedence (HTP) basis.

Step 1: Press **MAN**, and its associated red LED lights.

- The screen displays:



Step 2: Use **←** or **→** to select a channel number (active channel number is flashing), or **'T'** which controls all channels together.

Step 3: Use **↑** or **↓** to adjust the level. The dimmer output is live while the level is being adjusted.

Step 4: Press **ENT** to leave the menu and record the changes or **EXIT** to leave the previous settings unchanged.

### Operate the Chaser

The SmartBar/SmartModule has a sequence chaser to provide basic effects without a control desk. This can be used for exhibition and display lighting purposes.

Step 1: Press **CHAS**, and its associated red LED lights.

- The screen displays:

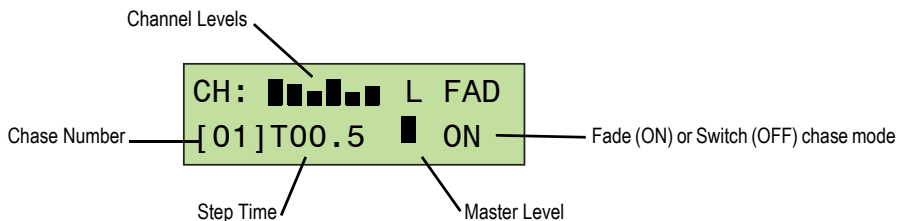

where:

- **CH** is chase number
- **T** is time (in seconds) from one step to another

- **L** is a bargraph showing the master intensity
  - **FAD** selects either a fading chase (ON) and a switching chase (OFF)
- Step 2: Use **←** or **→** to move the brackets around the screen, and use **↑** or **↓** to adjust the selected parameter.
- Step 3: With the chase number bracketed, use **↑** or **↓** to choose the desired chase pattern.
- Step 4: Move the brackets to **T** to adjust the chase rate as desired.
- Step 5: Move the brackets to **L** to set a new master intensity level as desired.
- Step 6: Move the brackets to **FAD** to make the chase fade [ON] or switching effect [OFF].
- Step 7: Press **ENT** to start the chase.
- Step 8: Press **ENT** a second time to stop the chase (ENT toggles the chase on & off).
- Step 9: Press **EXIT** to leave the chase functions.

## Section 5: Programming

---

### Flow Diagram

An overview of the flow chart showing the menu structure and options is shown in [“Menu Layout”, page 27](#).

### General Programming Advice

#### Passwords

For clarity, the following sections which describe programming activities do not refer to the entry of passwords. Passwords are included to prevent unauthorized access to the DMX, CONFigure and INSTall menu trees. The passwords are 4-digit numbers with a factory default of 0000 (no password necessary). It is possible to have the same password for all, or separate passwords for each menu tree. If any of the protected menus is selected, the subsequent screen requests a password. This is achieved by pressing the relevant **←** or **→** cursor buttons to select the digit, and the **↑** or **↓** cursor buttons to enter the number.

#### Navigation Through the Menus

The cursor buttons are used to move around the menu screens, and to activate a set-up option or parameter prior to adjustment. When a parameter or option is activated, it is shown in square brackets, (e.g. [15]) and it is this item which you are changing on the screen. When you press **ENT** to confirm the change, the screen will show:

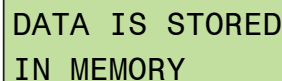

DATA IS STORED  
IN MEMORY

As this happens for each menu option, it is not included in each following instructions.

#### Channel Characteristics

All dimmer-specific functional parameters may be set on a dimmer-per-dimmer basis. Thus each dimmer may have a different response time, curve, maximum level, etc. if required. Alternatively, all dimmers in one SmartBar/SmartModule can be programmed together, depending on whether the dimmer set-up has been set to 'SINGLE' or 'JOINED' (See [“Change the Dimmer Characteristic Setup Scheme” on page 11](#)). If the configuration is set to single, a number is shown in each relevant channel reference **[4]**, and if all dimmers are programmed together, a **T** is shown in square brackets **[T]**.

## Front Panel Controls

All of the performance and control characteristics, measurements and status reports, are available from the front panel controls and LCD screen. When power is applied the power LED will illuminate. The DMX LED will illuminate if a valid DMX signal is present. If a valid DMX signal is not present, it will flash.

During the power-up reset process, the LCD display shows identification details and the software version before displaying the output screen:

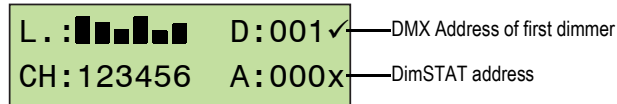

This display shows the channel levels (bargraphs at the top left), the DMX address of the first channel in the SmartBar/SmartModule (D:xxx) and the DimSTAT address of the unit (A:xxx). The number of bargraphs shown relates to the number of dimmers in the SmartBar/SmartModule - either 2, 4 or 6.



### **Note:**

An "X" behind the DMX address or DimSTAT address indicates that there is no valid DMX signal or DimSTAT communication. A check mark (✓) behind the DMX address indicates a valid signal and active DimSTAT communication.

## General controls

SmartBar/SmartModule have the capacity to store performance characteristics individually for each dimmer or combined for all dimmers in the group. This feature is independent of the choice of DMX numbering scheme, thus the dimmers may have individual characteristics, but with consecutive DMX addresses.

### **Change the Dimmer Characteristic Setup Scheme**

- Step 1: 1. Press **INST**.
- Step 2: Use **↑** or **↓** to choose **GENERAL SETTINGS** menu.
- Step 3: Press **ENT**.
- Step 4: Use **↑** or **↓** to choose **CONFIG CHANNEL** menu.
- Step 5: Press **ENT**.

- The screen

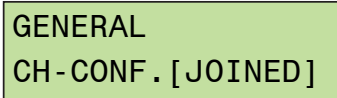

- Step 6: Use **↑** or **↓** to select either **SINGLE** (for different individual channel parameters) or **JOINED** (if all dimmers have the same characteristics).
- Step 7: Press **ENT** (to record the changes) or **EXIT** (to leave the previous settings unchanged, and return to the home page).

## DMX programming

Each dimmer in the SmartBar/SmartModule is assigned a DMX channel number. A feature is provided to set sequential number groups ('joined' addressing) instead of individual settings ('single' addressing).

### Set the DMX Addressing Scheme

- Step 1: Press **INST**.
- Step 2: Use **↑** or **↓** to choose **GENERAL SETTINGS** menu.
- Step 3: Press **ENT**.
- Step 4: Use **↑** or **↓** to choose **DMX ADDRESS** menu.
- Step 5: Press **ENT**.
  - The screen displays:

```
GENERAL
DMX MODE [ START ]
```

- Step 6: Use **↑** or **↓** to select either **SINGLE** (for different individual DMX addresses) or **START** (if the dimmers are numbered sequentially from the start address).
- Step 7: Press **ENT** (to record the changes) or **EXIT** (to leave the previous settings unchanged, and return to the home page).

### Set the DMX Addresses

- Step 1: Set the DMX scheme as described above (either single or start addressing).
- Step 2: Press **DMX**.
  - The screen displays:

```
DMX : [ 001 ]
CHAN. : 1
```

- Step 3: Configure the DMX address(es).
  - If **SINGLE** has been selected, two channels are displayed at a time, with their relevant DMX address. Use **↑** or **↓** to select the address needed for the first dimmer channel and move to other channels by pressing **←** or **→** and continue adjusting each DMX address by pressing **↑** or **↓** as before.
  - If **START** has been selected, only one DMX number is displayed (the first dimmer in this bar). Use **↑** or **↓** to select the address needed for the first dimmer channel. The remaining dimmers are automatically addressed in sequential order.
- Step 4: Press **ENT** to store the settings and to return to the previous menu.



---

**Note:**

*DMX address 000 deselects the channel from operation. Valid DMX numbers are between 001 - 512. If higher dimmer numbers are used by the control desk, the number has to be rationalized to a base of 512 for the dimmer address (e.g. channel 600 is: 600 - 512 = DMX address 88).*

---

## Set the DMX Backup Condition

The SmartBar/SmartModule is equipped with a choice of responses to the loss of a DMX signal. The dimmers can be set to hold their last DMX level, fade to zero after 10 seconds, or fade to a preset memory setting. This choice is available per dimmer.

Step 1: Press **INST**.

Step 2: Use **↑** or **↓** to choose **GENERAL SETTINGS** menu.

Step 3: Press **ENT**.

Step 4: Use **↑** or **↓** to choose **DMX FAIL** menu.

Step 5: Press **ENT**.

- The screen displays:

```
GENERAL
DMX FAIL [ RESET ]
```

Step 6: Use **↑** or **↓** to select one of the 3 options available:

**RESET:** sets all dimmers to zero after 10 seconds

**HOLD:** maintains the last valid DMX levels until DMX is restored

**BACKUP:** selects dimmer levels set-up through the backup memory facility

Step 7: Press **ENT** to leave the menu and record the changes or **EXIT** (to leave the previous settings unchanged).



---

**Note:** *If BACKUP has been set, do not forget to pre-set the relevant DMX backup state.*

---

## Set the DMX Backup Preset

Step 1: Press **INST**.

Step 2: Use **↑** or **↓** to choose DMX BACKUP menu.

Step 3: Press **ENT**.

- The screen displays:

```
BACK%: [ 000 ] 000
CHAN. :   1   2
```

Step 4: Use **←** or **→** to select a channel number level (active channel level is in brackets).

Step 5: Use **↑** or **↓** to adjust the backup level. The dimmer output is live while the backup levels are adjusted.

Step 6: Press **ENT** to leave the menu and record the changes or **EXIT** (to leave the previous settings unchanged).

## Set the DMX Minimum Reset

DMX minimum reset is the automatic means to switch any preheat levels off when DMX is not present (i.e. when the control desk is switched off, but the dimmers remain on).

Step 1: Press **INST**.

Step 2: Use **↑** or **↓** to choose **GENERAL SETTINGS** menu.

Step 3: Press **ENT**.

Step 4: Use **↑** or **↓** choose **MINIMUM RESET** menu.

Step 5: Press **ENT**.

- The screen displays:

```
GENERAL
MIN.RESET [OFF]
```

Step 6: Use **↑** or **↓** to select either **ON** (preheat switches off when DMX is off) or **OFF** (preheat runs continuously).

Step 7: Press **ENT** to leave the menu and record the changes or **EXIT** (to leave the previous settings unchanged).

## Set the Serial Address

The DimSTAT PC address which shown on the output screen as A:xxx is the unique number which is used by network to identify each dimmer unit for the purpose of reporting status information and for transferring data between the dimmer unit and PC. If a dimmer unit is removed from the network and replaced by another, DimSTAT will automatically prompt for an update of configuration information when the PC number is entered. DimSTAT identifies the new unit on the network, and prompts the operator to download the previous characteristics file from the PC to the new dimmer. The PC number is associated with a unique factory serial number which is permanently stored in the dimmer.

### Set the Serial Address

Step 1: Press **INST**.

Step 2: Press **↑** or **↓** to choose **DIMSTAT ADDRESS** menu.

Step 3: Press **ENT**.

- The screen displays:

```
ADDRESS : [ 000 ]
ENTER  ←      ↑↓
```

Step 4: Use **↑** or **↓** to set the address number between 001 and 255.

Step 5: Press **ENT** to leave the menu and record the changes or **EXIT** (to leave the previous settings unchanged).

## Maximum & Minimum levels

You can affect the output level of a dimmer by setting a minimum level and/or a maximum level. A minimum level is used to provide a pre-heat to preheat lamp filaments, whereas the maximum level is used to limit power and extend lamp life. Minimum levels may be set between 0% to 29.9%, and maximum levels from 30% to 100%. Factory default levels are 0% for minimum and 100% for maximum.



**Note:** *In the case of high-inrush loads (e.g. PARcans) where flashing on from a cold state is required, a preheat level of 5% is recommended. See also “Set the DMX Minimum Reset”, page 13.*

### Set Max. & Min. Levels

Step 1: Press **CONF**.

The screen shows the individual channel number (or **T** if the dimmer set-up scheme copies characteristics to all dimmers in the rack) and gives access to all configuration options.

Step 2: Use **←** to move the brackets to the channel number.

- The screen displays:

```
CONFIG:  CH: [ 1 ]
MAX  100.0  %
```

Step 3: Use **↑** or **↓** to select the required dimmer number.

Step 4: Use **→** to move the brackets to the parameter list.

Step 5: Use **→** to select the **MAX** or **MIN** option and to highlight the recorded value (in brackets).

- The screen displays:

```
CONFIG:  CH: 1
MIN [ 000.0 ] %
```

Setting options are:

**MIN:** minimum level from 00% to 29.9%.

**MAX:** maximum level from 30% to 100%.

Step 6: Use **↑** or **↓** to select the level (shown in brackets).

Step 7: Press **ENT** to leave the menu and record the changes or **EXIT** (to leave the previous settings unchanged).

## Response time

Each dimmer has two times associated with it which control the minimum time to fade in and out, and are called T-IN and T-OUT. These times are referred to as 'response times' and are used to protect the lamp filaments from thermal damage, and for reducing surges in the system. The default times are currently set at 20 milliseconds for the fastest response.

Values recommended are 0.01s for a 1kW load or 0.1s for a 2kW load.

### Set Dimmer Response Times

Step 1: Press **CONF**.

The screen shows the individual channel number (or **T** if the dimmer set-up scheme copies characteristics to all dimmers in the rack) and gives access to all configuration options.

Step 2: Use **←** or **→** to move the brackets to the channel number.

- The screen displays:

```
CONFIG:  CH: [ 1 ]
MAX  100.0  %
```

Step 3: Use **↑** or **↓** to select the required dimmer number.

Step 4: Use **→** to move the brackets to the parameter list.

Step 5: Use **→** to select the response times **T-IN** or **T-OUT** and to highlight the recorded value (in brackets).

- The screen displays:

```
CONFIG:  CH: 1
T.OUT [ 00.02 ] s
```

Step 6: Use **↑** or **↓** to select the time (shown in brackets).

Step 7: Press **ENT** to leave the menu and record the changes or **EXIT** (to leave the previous settings unchanged).

## Dimmer Curves

Dimmer curves are used to adjust the relationship between control level and light output. This enables the dimmer to be fine-tuned to accommodate the preferences of a live audience or a television camera. There are ten factory standard dimmer curves, and a provision for further custom selectable curves in later software releases. The factory default curve (0) is Linear. The list of dimmer curves is as follows:

<b>LINEAR:</b>	Linear relationship (default)
<b>BBC:</b>	BBC specification (modified square law for TV applications)
<b>S-LAW:</b>	S-Law
<b>INV.LIN:</b>	Inverted (when control = zero, dimmer = full etc.)
<b>TVE:</b>	Creates a BBC curve with a fluorescent ballast (switch to 40% at 5% control).
<b>FLU-30:</b>	Fluorescent (minimum 30%)
<b>110VLIN:</b>	110V lamp load, linear law
<b>FLASH:</b>	Flash effect (light switches on and off as the control fades up and down).
<b>NONDIM:</b>	Non-Dim operation (see note below)
<b>2kWL:</b>	Linear curve with a S-law first 15%
<b>Usr1 - Usr6:</b>	For user definable custom curves



---

### Note:

*There are two options for setting Non-Dim (switch) operation - via the CURVE menu and the NON-DIM menu, both found in CONF. For Non-Dim operation, either or both options may be set, but for normal dimmer operation BOTH must be set to 'NO'.*

---

### Set a Dimmer Curve

Step 1: Press **CONF**.

The screen shows the individual channel number (or **T** if the dimmer set-up scheme copies characteristics to all dimmers in the rack) and gives access to all configuration options.

Step 2: Use **←** to move the brackets to the channel number.

- The screen displays:

```
CONFIG:  CH: [ 1 ]
MAX 100.0 %
```

Step 3: Use **↑** or **↓** to select the required dimmer number.

Step 4: Use **→** to move the brackets to the parameter list.

Step 5: Use **→** to select the **CURVE** setting and to highlight the recorded value (in brackets).

- The screen displays:

```
CONFIG:  CH: 1
CURVE [LINEAR]
```

- Step 6: Use **↑** or **↓** to select the curve option (shown in brackets).
- Step 7: Press **ENT** to leave the menu and record the changes or **EXIT** (to leave the previous settings unchanged).

## Start Mode

SmartBar/SmartModule are equipped with a software feature to alter the criteria for dimming cold filaments. The response of a dimmer depends on the resistance of the filament, which varies according to temperature. A cold filament has a slower response than a warm filament. If the complete rig is subject to a sudden loss and resumption of power (a 'brown-out') it is possible for the combined cold switch-on load to be higher than the diversified power supply can withstand, resulting in nuisance tripping of circuit breakers. For this reason, the dimmers are installed with a range of start modes to give the users flexibility in the set-up characteristics of the dimmer.

- BASIC:** Normal mode
- SOFT:** If the circuit has not been used for 5 minutes, the initial response time is automatically set to 500ms

### Set Start Mode

- Step 1: Press **CONF**.

The screen shows the individual channel number (or **T** if the dimmer set-up scheme copies characteristics to all dimmers in the rack) and gives access to all configuration options.

- Step 2: Use **←** to move the brackets to the channel number.

- The screen displays:

```
CONFIG:  CH: [ 1 ]
MAX 100.0 %
```

- Step 3: Use **↑** or **↓** to select the required dimmer number.

- Step 4: Use **→** to move the brackets to the parameter list.

- Step 5: Use **→** to select the start **MODE** option and to highlight the recorded value (in brackets).

- The screen displays:

```
CONFIG:  CH: 1
MODE [ BASIC ]
```

- Step 6: Use **↑** or **↓** to select the start **MODE** option (shown in brackets).

- Step 7: Press **ENT** to leave the menu and record the changes or **EXIT** (to leave the previous settings unchanged).

## Passwords

Passwords are used at 3 levels of the SmartBar/SmartModule dimmer set-up procedure: DMX, CONF. and INST. One password or 3 separate passwords may be used to give a range of access options. Passwords are in the form of 4 digit codes and may be set and used from the front panel of the dimmer and DimSTAT, but passwords may only be read using DimSTAT. Passwords set at 0000 give unlimited access (factory default).



**Note:** *If the password is set to 0000 (factory default) the menus are open, and no prompts to enter a password are seen on the display.*

## Setup Passwords



**Note:** Programming passwords for DMX programming, Channel configuration and Installation follows the same procedure which is described here for DMX only.

- Step 1: Press **INST**.
- Step 2: Press **↑** or **↓** to choose **PASSWORD DMX** menu.
- Step 3: Press **ENT**.
- The screen displays:

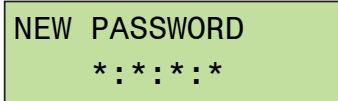

```
NEW PASSWORD
* : * : * : *
```

- Step 4: Use **↑** or **↓** to adjust the digit.
- The screen displays:

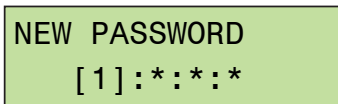

```
NEW PASSWORD
[ 1 ] : * : * : *
```

- Step 5: Use **←** or **→** to select a digit to enter (shown in brackets).



**Note:** Make a copy of passwords set in the back of this handbook, as the passwords can be found only via a DimSTAT link to a remote PC.

Resetting the password to 0000 disables the previous setting.

- Step 6: Press **ENT** to leave the menu and record the changes or **EXIT** (to leave the previous settings unchanged).

## Sleep mode

The SLEEP function has been included to switch off the backlit LCD screen during a performance when the control panels are in view of an audience or camera. When enabled, the sleep function switches off the backlight a short time after the last touch of a panel button, and switches back on when a front panel button is pressed.

### Set the dimmer rack to 'Sleep' mode

- Step 1: Press **INST**.
- Step 2: Use **↑** or **↓** to choose **GENERAL SETTINGS** menu.
- Step 3: Press **ENT**.
- Step 4: Use **↑** or **↓** to choose **SLEEP MODE** menu.
- Step 5: Press **ENT**.
- The screen displays:

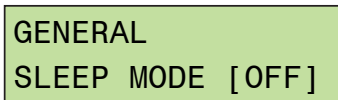

```
GENERAL
SLEEP MODE [ OFF ]
```

- Step 6: Use **↑** or **↓** to select either ON or OFF.
- Step 7: Press **ENT** to leave the menu and record the changes or **EXIT** (to leave the previous settings unchanged).

## Fault reporting

The SmartBar/SmartModule will report if a dimmer is overheating, or if there is an over voltage. The CHK LED illuminates if a fault is recorded and any circuit errors are reported on the screen above the channel number affected. Example as shown below for channel 4 which is displaying a temperature overheat condition:

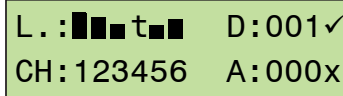

```
L.:■■■t■■ D:001✓
CH:123456 A:000x
```

where:

code 't' = over temperature (>78°C/172°F)

code 'u' = over voltage present (>275V AC)

The channel display indicators give the last recorded fault condition. A log of the errors is shown in detail through DimSTAT, and a summary of the history is shown using the dimmer's LCD screen in the next topic below.

### Check Error Messages & Reset the Log

Step 1: Press **CHK**.



#### Note:

*This screen never requires a password.*

- If there is no error, the screen shows the following message for 3 seconds:

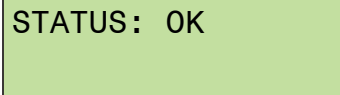

```
STATUS: OK
```

- If there is an error, the screen displays:



```
STATUS: CH
OVERTEMP 01
```

Error type — Channel number of the error

Step 2: Use **↑** or **↓** to view any other messages in the error log.

Step 3: Press **ENT** to leave the menu and **clear** the log or **EXIT** (to leave the log unchanged).

## Restore Factory Defaults

The SmartBar/SmartModule is supplied with a set of factory default settings and recommended software set-up parameters. It is advisable to reset the dimmer software to the original factory settings in the case of a significant software update.

### Reset to Factory Default Settings

Step 1: Press **INST**.

Step 2: Use **↑** or **↓** to choose **FACTORY RESET** menu.

Step 3: Press **ENT**.

- The screen displays:

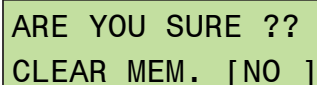

```
ARE YOU SURE ??
CLEAR MEM. [NO ]
```

Step 4: Use **↑** or **↓** to select **YES**.

Step 5: Press **ENT** to leave the menu and reset the dimmer's memory or **EXIT** (to leave

the previous settings unchanged).

**Factory defaults are:**

**CHANNEL CONFIG:** JOINED

**CURVE:** LINEAR

**DMX ADDRESS:** 001

**DMX BACKUP:** all 00

**DMX FAIL:** RESET

**DMX MODE:** JOINED

**DMX MINIMUM RESET:** OFF

**FREQUENCY:** 50Hz

**MAXIMUM:** 100%

**MINIMUM:** 0.00%

**MODE:** BASIC

**NON-DIM (I/O):** NO

**PASSWORDS:** all 0000

**PC ADDRESS:** 000

**SLEEP:** OFF

**T-IN:** 0.02 secs.

**T-OUT:** 0.02 secs.

## Section 6: DimSTAT

---

DimSTAT provides a system-wide network, and operates on a host polling protocol where the PC searches for connected dimmers at initiation, and then regularly polls dimmers for data to display.

If a fault occurs, the PC's display instantly shows the detail, and if the fault is cleared the system resets accordingly. Information displayed includes: DMX start address per unit, DMX OK, line voltage, current per channel, dimmer curve, response time, max. setting, type of fault reported (temperature, overload etc.), date and time of fault. It is possible to set the dimmer curve, start address and pre-heat from DimSTAT software on the PC.

The operation and performance of the SmartBar/SmartModule is monitored constantly by the on-board data processors, and this information is available on the LCD screen of the dimmer, and through DimSTAT. The parameters measured and reported are:

- DMX OK
- DMX channel numbers
- DMX levels
- Frequency
- Dimmer curve
- Temperature

Active voltage, frequency, current, cos phi is only measured by appropriate hi-level variants

of these dimmers. For further information, please refer to the DimSTAT software manual.

## Section 7: Faults & Troubleshooting

---

### Reported Faults

#### Over Temperature

If one of the dimmer channels exceeds an operating temperature of 78°C (172°F), the dimmer will switch off and report an over temperature condition. This can be caused if the ventilation is obstructed (e.g. the dimmer is resting on the floor and is being used continuously at full load).

#### No Load (control present but no output) [SmartModule Only]

This can be reported if either a load fails (lamp blows or fuse has failed), or the load is disconnected in error, or a load is not connected.

### First Line Troubleshooting

This check list provides initial assistance in the case of a problem which has not been identified and reported by the dimmer's own software.

#### LCD Display Blank

Check all power supply connections.

#### No Output from One Channel

Check the channel breaker or fuse. Check the control signal is active. Check the DMX address is correct.

#### Breaker Trips Continuously

Unplug all load plugs. Check the circuit (cables, plugs and sockets, distribution, lights) for a loose terminals, a phase to neutral short, a phase to earth short or a neutral to earth short. Correct where necessary. If the fault persists, refer to service technician.

#### Dimmer Output is Stuck On Full

Disconnect the DMX cable to isolate control. If the dimmer is still on, check a) the MANUAL level has not been set to 100%; b) the dimmer curve has not been set to 'Inverted'; c) the MIN level is at zero. If the dimmer is still on refer to a service technician.

If the dimmer switches off when the DMX cable is removed, check that both NON-DIM mode selections (dimmer curve and Channel Configuration I/O) are set to OFF. If either or both these functions are set ON, the dimmer will be operating in Non-Dim mode.



# Appendix A: Specifications

---

## SmartBar/SmartModule Control Features

- DMX512 In and Thru via 5Pin XLR connectors.
- Supports up to 32 SmartBars on one DMX line (Opto-splitter recommended for additional units).
- 2-line by 16-character backlit LCD for system configuration, status display and error indication.
- 9-button keypad plus arrow array and Enter button.
- 2 status LED indicators: Power and Valid DMX.
- Flexible programming of individual dimmer characteristics:
  - Maximum and minimum levels
  - Response speed
  - Local control or live manual control
  - 20 pre-programmed effect sequences
  - Selection of standard Dimmer Curves
  - Non-dim operation
  - Start Mode for dimming cold filaments – Normal, Soft, Burst, Proportional or Blink
  - Status Reporting
  - Backup settings - Selectable Data Loss Behavior
- Password protection for access to DMX, Configuration and Install menus

## SmartBar Specification

### General

- 4 or 6 dimmer versions available
  - 4x6A and 6x6A
  - 6x10A
- Conforms to 
- Installation requires attachment for safety cables
- Main power via flexible cable in 4 channel bars, via HAN chassis connector in 6 channel versions
- Data via DMX512.

## Physical

<b>Model</b>	<b>Height</b>	<b>Width</b>	<b>Length</b>	<b>Weight</b>
	<b>mm</b>	<b>mm</b>	<b>mm</b>	<b>kg</b>
SB4-6 short	60	40	1200	5.2
SB4-6	60	40	1500	5.5
SB6-6	60	80	2200	5.6
SB6-10	60	80	2200	12.6

## Mechanical

- Manufactured of aircraft quality anodized aluminum
- Integrated suspension points for fixtures and for mounting hardware (i.e. C-clamps or stand adaptors).
  - Supplied with five or seven (depending on # of channels) M10x80mm bolts and appropriate hardware for fixture mounting.
- Convection cooled - operates without cooling fans or filters.

## Electrical

- 230/400V 50Hz Mains supply
- 4x6A: Single Phase 2-wire plus ground, 20A feed
- 6X6A and 6x10A: Three Phase 4-wire plus ground, 32A feed
- Total load can not exceed capacity of main power connection (i.e. wall outlet 15A, 20A).
- Power wiring by use of an attached flexible 3m neopreen feed cord and bare ends. Connector is not supplied by ETC. All 6 channel bars use HAN chassis connector (no cable).
- 10 Watt minimum load per dimmer
- Fuse for load protection per dimmer (10A SmartBars available with circuit breakers).
- Choice of SCHUKO, CEE17, French SCHUKO, UK 13A, UK 15A Round Pin, and SWISS outlets (1 per circuit).
- Single convenience outlet centered on bar.

# SmartModule Specification

## General

- Six 10A dimmers.
- Conforms to 
- Installation requires attachment of safety cables
- Main power via flange mount CEE 32A 5P
- Data via DMX512

## Physical

Model	Height	Width	Length	Weight
	mm	mm	mm	kg
SM6-10	205	125	451	9.1

## Mechanical

- Manufactured of aircraft quality anodized aluminum.
- Integrated suspension points (threaded studs) for mounting hardware such as c-clamps.
- Convection cooled - operates without cooling fans or filters.

## Electrical

- 230V 50Hz Mains supply.
- 230/400 Three-phase, 4-wire plus ground, 20A feed.
- Power feed via a flange-mount CEE 32A 5P.
- 10 Watt minimum load.
- One circuit breaker per dimmer for load protection.
- Choice of SCHUKO, CEE17, French SCHUKO, or UK 15A Round Pin outlets (1 per circuit).
- Convection cooled - operates without cooling fans or filters.





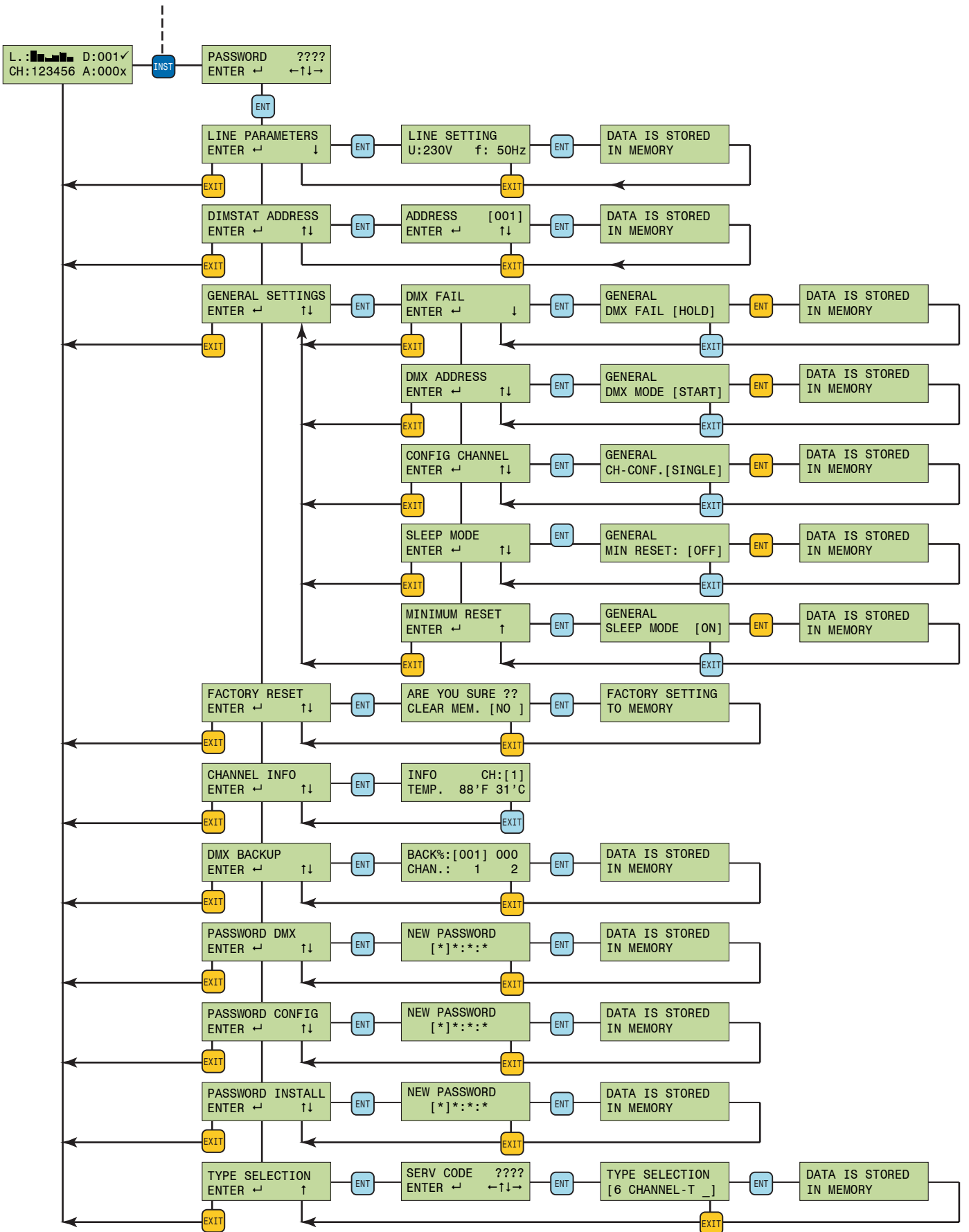



**Corporate Headquarters** ■ 3031 Pleasant View Road, P.O. Box 620979, Middleton, Wisconsin 53562-0979 USA ■ Tel +608 831 4116 ■ Fax +608 836 1736  
**London, UK** ■ Unit 26-28, Victoria Industrial Estate, Victoria Road, London W3 6UU, UK ■ Tel +44 (0)20 8896 1000 ■ Fax +44 (0)20 8896 2000  
**Rome, IT** ■ Via Ennio Quirino Visconti, 11, 00193 Rome, Italy ■ Tel +39 (06) 32 111 683 ■ Fax +39 (06) 32 656 990  
**Holzkirchen, DE** ■ Ohmstrasse 3, 83607 Holzkirchen, Germany ■ Tel +49 (80 24) 47 00-0 ■ Fax +49 (80 24) 47 00-3 00  
**Hong Kong** ■ Room 605-606, Tower III Enterprise Square, 9 Sheung Yuet Road, Kowloon Bay, Kowloon, Hong Kong ■ Tel +852 2799 1220 ■ Fax +852 2799 9325  
**Service:** (Americas) [service@etcconnect.com](mailto:service@etcconnect.com) ■ (UK) [service@etc europe.com](mailto:service@etc europe.com) ■ (DE) [techserv-hoki@etcconnect.com](mailto:techserv-hoki@etcconnect.com) ■ (Asia) [service@etcasia.com](mailto:service@etcasia.com)  
**Web:** [www.etcconnect.com](http://www.etcconnect.com) ■ Copyright © 2005 ETC. All Rights Reserved. ■ Product information and specifications subject to change.  
7521M1200-1.42-GB ■ Rev A ■ Released 07/2005