

Source Four[®] Zoom

Assembly Guide

Production Dates: September 2004 - Present

ATTENTION: The part numbers listed in this guide may differ from the parts required for your particular Source Four fixture. Part numbers for fixtures change occasionally as parts are replaced or upgraded.

To ensure that you are ordering the proper part for your specific fixture, please contact your ETC dealer, or ETC Customer Service for assistance.

Table of Contents

15°-30° Basic Fixture	1
25°-50° Basic Fixture	2
Assembling Basic Fixture	2
Lamp Socket Assembly	3
Assemble lamp socket.	4
Reflector Housing Assembly	7
Removing reflector.	7
Installing reflector.	8
.	8
Cleaning reflector.	8
Front Barrel Assembly	9
Assemble front barrel assembly	10
15°- 30° Lens Tube	12
15°- 30° Lens tube assembly.	13
15°- 30° Gel frame endcap assembly	13
15°- 30° Front lens assembly.	13
15°- 30° Rear lens assembly	13
25°- 50° Lens Tube	14
25°-50° lens tube assembly.	15
25°- 50° Gel frame endcap assembly	15
25°- 50° Front lens assembly.	15
25°- 50° Rear lens assembly	15
Assemble lens tube (15°-30° and 25°-50°)	16
Cleaning glass lens	17

ETC[®], Emphasis[®], Expression[®], Insight[™], Imagine[™], Focus[™], Express[™], Unison[®], Obsession[®] II, ETCNet2[™], EDMX[™], Source Four[®], Revolution[®], Sensor[®], and WYSILink[™] are either registered trademarks or trademarks of Electronic Theatre Controls, Inc. in the United States and other countries.

All other trademarks, both marked and not marked, are the property of their respective owners.

15°-30° Basic Fixture

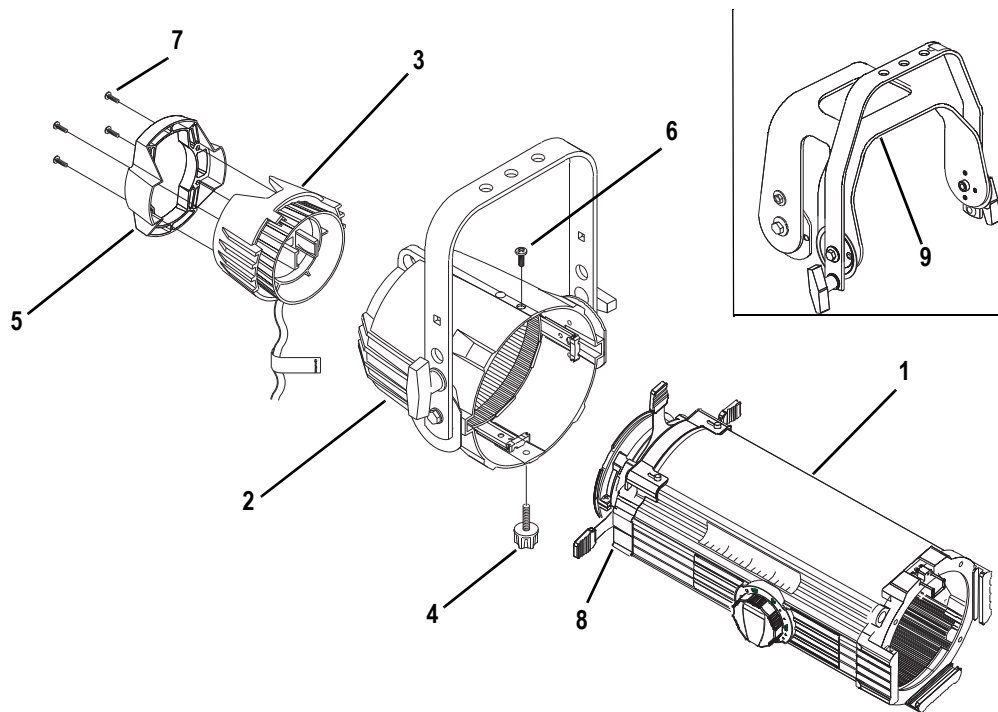

Figure 1

Reference Number	Part Number	Description	Quantity Required
1	7060A2030	15°-30° lens tube	1
2	7060A2020	Reflector housing assembly, double clutch	1
3	7060A2008	Lamp socket assembly	1
4	7060A4008-01	Knob set with male insert	1
5	7060A4037	Handle, insulated rear	1
6	HW5197	Screw, 1/4-20 x 5/8, black zinc	1
7	HW2181	Screw, 6-32 x 3/4, black Taprite	4
8	see page 9	Front barrel assembly	
Optional			
9	7060A2028	Balance Yoke	1

25°-50° Basic Fixture

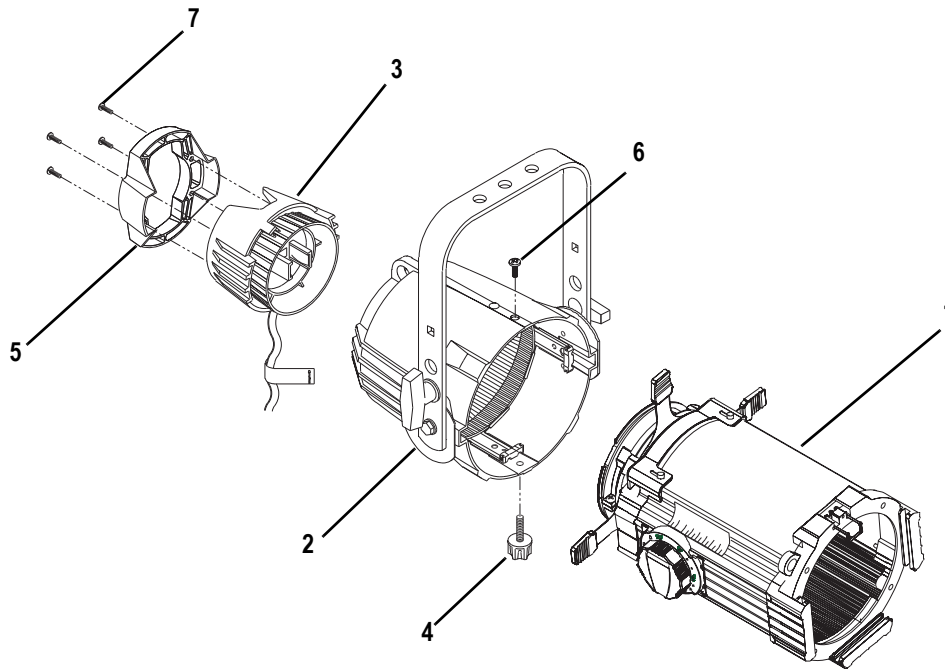

Figure 2

Reference Number	Part Number	Description	Quantity Required
1	7060A2032	25°-50° lens tube	1
2	7060A2020	Reflector housing assembly, double clutch	1
3	7060A2008	Lamp socket assembly	1
4	7060A4008-01	Knob set with male insert	1
5	7060A4037	Handle, insulated rear	1
6	HW5197	Screw, 1/4-20 x 5/8, black zinc	1
7	HW2181	Screw, 6-32 x 3/4, black Taprite	4

Assembling Basic Fixture

- Step 1: Follow instructions under [Assemble lamp socket, page 4](#).
- Step 2: Follow instructions under [Installing reflector, page 8](#).
- Step 3: Follow instructions under [Assemble front barrel assembly, page 10](#)
- Step 4: Follow instructions under [Assemble lens tube \(15°-30° and 25°-50°\), page 16](#).
- Step 5: Insert lens tube assembly (1) fully into the reflector housing assembly (2). Turn lens tube assembly 1/4 turn and align the two mounting holes. Secure with screw (6) on top, and knob (4) on bottom. Tighten both securely. See [Figure 1](#) or [Figure 2](#).
- Step 6: Install the lamp socket assembly (3) to the reflector housing (2) and secure with brass knurled screw on rear of lamp socket assembly.
- Step 7: Release the gel retaining clip by pushing it sideways while gently pulling backwards.
- Step 8: Insert the color frame.
- Step 9: Lock the clip by pushing sideways while gently pushing it forward.

Lamp Socket Assembly

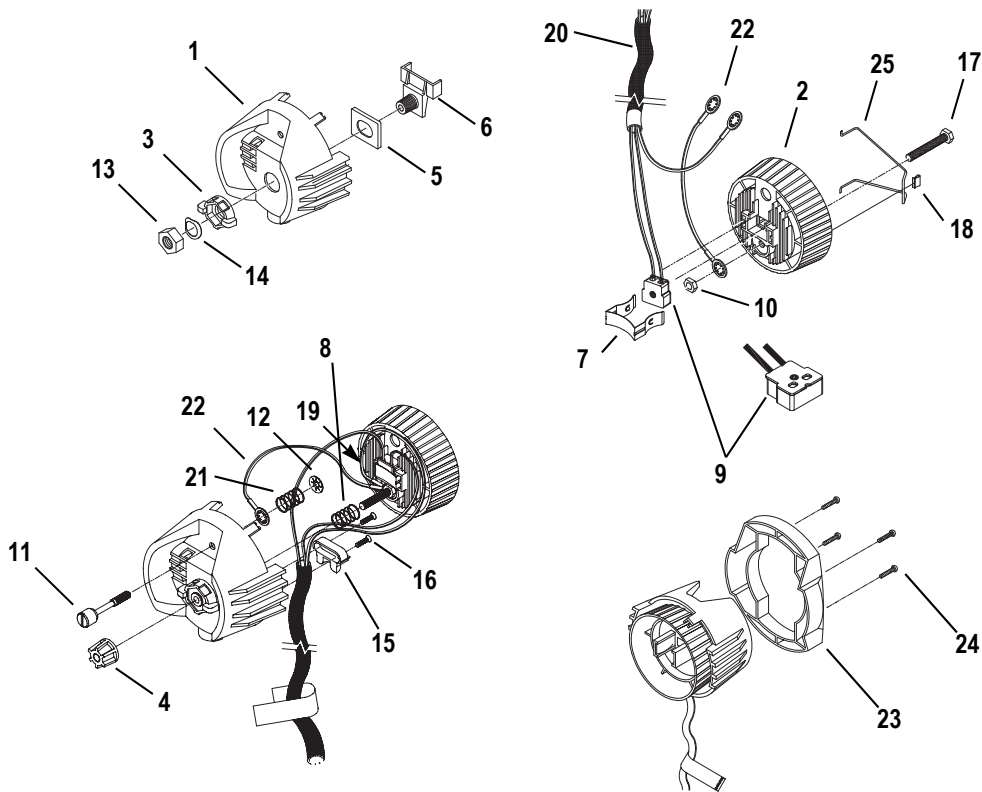

Figure 3

Reference Number	Part Number	Description	Quantity Required
1	7060A3055	Housing, socket, casting, painted	1
2	7060A3007	Socket, light baffle casting, raw	1
3	7060A4007	Knob, X-Y, lamp set	1
4	7060A4008-02	Knob, Z, lamp set w/female insert	1
5	7060A4011	Bushing, cup	1
6	7060A3011	Hub, index, casting	1
7	7060A3012	Spring, lamp retainer	1
8	HW748	Spring, compression	1
9	7060B7019	Complete UL socket assembly	1
10	HW534	Nut, hex, 1/4-20, black zinc	1
11	7060A3025	Screw, 1/4-20 knurled head	1
12	HW746	Retaining ring, flat, Southco	1
13	HW5123	Nut, hex, 9/16-18, black zinc	1
14	HW747	Washer, wave	1
15	7060A3056	Clamp, strain relief, painted	1
16	HW3103	Screw, 8-32 x 5/8 PhFHMS, black zinc	2
17	HW5122	Bolt, 1/4-20 x 1.75, full thread, black zinc	1
18	HW8209	Clip Tinnerman	1
19	7060B7003	48" W420 wire, 16 gauge, 200° C/300V, green UL 1180/CSA AWM with lug J490T installed	1
20	W6195	36" sleeve, fiberglass	1
21	HW749	Spring, ground	1
22	7060B7007	4" W420 wire, 16 gauge, 200° C/300V, green, UL 1180/CSA AWM with two J490T lugs installed	1
23	7060A4037	Handle, insulated rear, black	1
24	HW2181	Screw, 6-32 x 3/4, Taptite	4
25	7060A3085	Source Four Lamp Retainer Wire	1

Assemble lamp socket

Tools Required:

- Open-end adjustable wrench or a 7/16" socket
- Needle-nose pliers
- #2 Phillips screwdriver

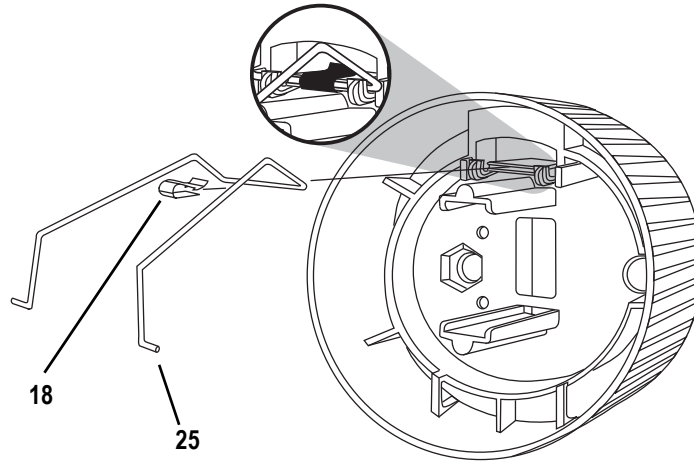

Figure 4

Step 10: Set the crossbar of the retainer clip (25) under the two hooks on the clip bracket as shown in [Figure 4](#).

Step 11: Place the Tinnerman clip (18) over the retainer clip crossbar between the two hooks and press it down firmly until it snaps into place.

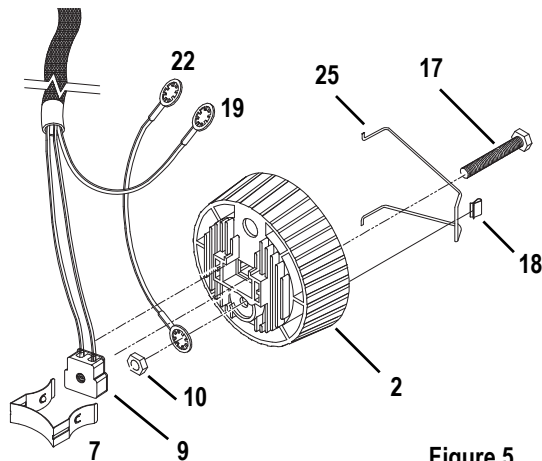

Figure 5

Step 12: Insert the bolt (17) through the light baffle socket casting (2). See [Figure 5](#).

Step 13: Install the green ground wire assemblies (19 and 22) on the bolt (17) with the prongs on the crimped connectors toward the casting. Run both wires through the indent in the lip around the bolt hole. Secure with nut (10) and tighten securely (60 inch pounds).

Step 14: Place the socket assembly (9) into the light baffle socket casting (2). Be sure it is well seated.

Step 15: Install the lamp retainer spring (7). The lamp retainer spring secures the socket. Insert the spring one end at a time, making sure the rectangular slot in each side of the spring seats on the corresponding tab in the casting.



Note:

If the spring does not seat correctly, coax it into place with a screwdriver or needle-nose pliers.

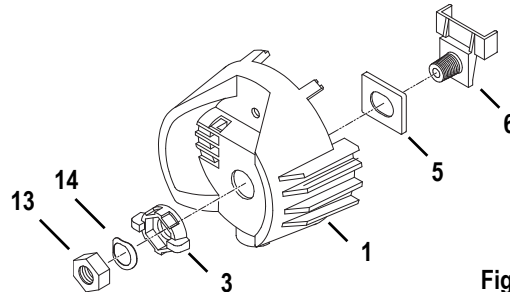

Figure 6

Step 16: Install the bushing cup (5) into the housing socket casting (1) as shown in [Figure 6](#). The cup should slide smoothly up and down, but not side to side.

Step 17: Insert the threaded end of the index hub (6) through the holes in the bushing cup and the back of the housing socket casting (1).

Step 18: Slide the X-Y knob (3) over the exposed index hub bolt (6), then insert the wave washer (14) on the bolt and secure with the 9/16 hex nut (13). Hand tighten the X-Y knob (3).



Note:

Install the wave washer with the upward curve toward the hex nut.

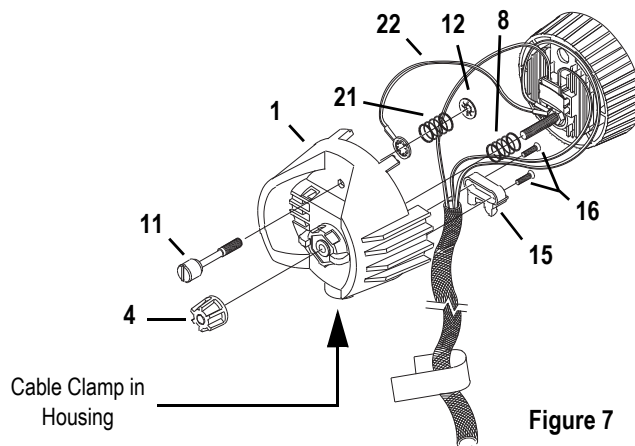

Figure 7

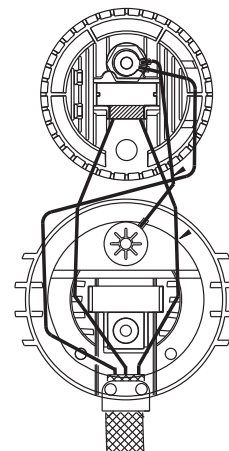

Figure 8

Step 19: Insert the knurled head screw (11) through the housing socket casting (1) as shown in [Figure 7](#).

Step 20: Install the shorter green ground wire (22) onto the screw. The prongs on the crimped connector should be toward the casting.

Step 21: Install the ground spring (21) onto the screw and secure it with the Southco flat retaining ring (12). Install the Southco ring with its prongs away from the casting.



Note: Use pliers to straighten the Southco retaining ring (12) if it bends when you install it on the bolt.

Step 22: Lay the leads in the bottom half of the cable clamp (located in the housing socket casting [1]), making sure that the fiberglass sleeving extends slightly past the screw holes in the housing socket casting. Install new sleeving if necessary. Then, route the wires as shown in [Figure 8](#).



CAUTION: You must follow the wire routing diagram to ensure that the socket leads do not interfere with the lamp focus mechanism.

Step 23: Install the top half of the cable clamp (15) and secure it with the two screws (16). Tighten the screws alternately to ensure a solid connection.



Note: To ensure that the clamp holds the cable tightly, flatten the cable, then fold over the sleeving before you install the top half of the clamp. Make sure the top edge of the cable clamp is even with the edge of the socket to prevent interference with lamp focus movement. Make sure sleeving is not pinched.

Step 24: Using the four screws (24), attach the handle (23) to the lamp socket assembly. See [Figure 3](#).

Step 25: Place the compression spring (8) on the protrusion on the inside of the index hub (6).

Step 26: Insert bolt (17) through spring (8) and through the index hub (6) of the housing socket (1), joining the two castings. Make sure wires are not pinched between the two pieces.

Step 27: Before proceeding, check again to make sure the wires are still positioned as indicated in Figure 6. Adjust if necessary.

Step 28: Press the two castings together firmly so the bottom of the light baffle (2) sits on top of the cable clamp (15), then install the X-Y lampset (3) and Z lamp knob (4). Hand tighten the knob all the way to the right.



CAUTION: You must install Z knob as described above to ensure proper lamp focus travel.

Reflector Housing Assembly

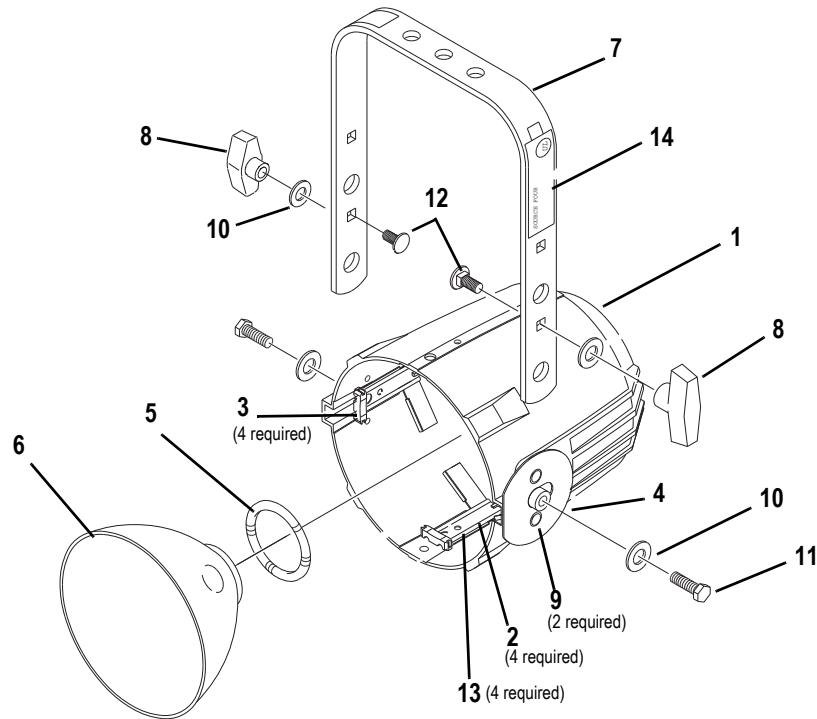

Figure 9

Reference Number	Part Number	Description	Quantity Required
1	7060A3054	Housing, reflector casting, painted black	1
2	7060A3006	Clip, reflector retainer	4
3	7060A4010	Bushing, gate	4
4	7060A3016	Plate, clutch	1
5	7060A3019	Spring, reflector support	1
6	7060A4015	Reflector, molded glass, coated	1
7	7060A3058	Bracket, yoke, painted	1
8	HW8144	Handle, yoke knob, 5/16 - 18	2
9	HW753	Rivet, machine, 3/16 x .720, flat head, black zinc	2
10	HW5126	Washer, flat, 5/16, black zinc	4
11	HW5193	Bolt 5/16-18 x 3/4, black zinc	2
12	HW5125	Bolt, carriage, 5/16-18 x .75, black zinc	2
13	HW752	Rivet machine, 3/16 x 5/16, black zinc	4
14	7060A4088	Label, S4 750w UL	1

Removing reflector

Tools Required:

- Minimally padded work surface (cardboard, carpet, or rubber mat recommended)



WARNING: *This procedure may crack or break the reflector. Always wear gloves, safety glasses, and a dust mask when performing this procedure.*

- Step 1: Place the reflector housing face down on your work surface so that the concave reflector surface points downward.

- Step 2: Loosen the clutch and rotate the yoke so that it is perpendicular to the housing at roughly a 90° angle. Tighten the clutch.
- Step 3: Using the yoke as your handle, raise the housing assembly off of the work surface a few inches and then firmly tap the housing on the work surface. This should force the reflector out of its clips.
- Step 4: Carefully lift the housing to see if the reflector is released. If it is not, repeat step 3 with slightly more force.

Installing reflector



Note: *The following assumes all four reflector retainer clips (2) have already been riveted to the reflector housing casting (1) and the gate bushings (3) installed on the retainer clips. See [Figure 9](#).*

- Step 1: Place the reflector housing casting (1) on a flat work surface with the large opening facing up.
- Step 2: Install the reflector support spring (5) in the circular opening at the base of the casting.
- Step 3: Insert the reflector (6) at an angle, under any three adjacent legs of the reflector's clips.
- Step 4: Gently press down on the opposite side of the reflector until it snaps into place under the remaining clips.



Note: *If the reflector does not snap in, turn the casting over. Gently pull on the side of the reflector that has not snapped in until the rest of the reflector slides into place.*

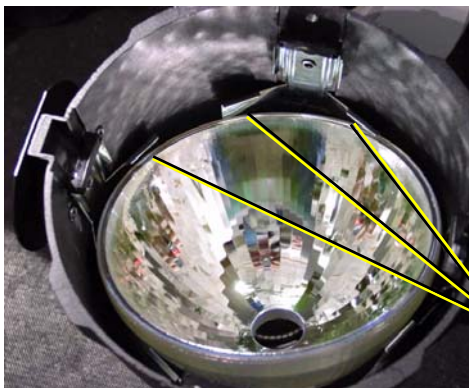

Step 3

Under three adjacent clips.



Step 4

Cleaning reflector



WARNING: *Do not use ammonia-based or other harsh commercial cleaners. Clean reflector only as directed. Commercially available glass cleaning agents should be avoided as they may contain ammonia, other harsh chemical detergents or abrasive agents. These cleaners may damage the glass surface and the Anti-Reflective coatings. Do not immerse or soak the glass in any cleaning solution.*

Remove dust with a blast of oil-free air or wipe with a clean, lint-free cloth. Isopropyl alcohol, distilled water or a 50%-50% mixture of each can be used to clean the glass surface.

Front Barrel Assembly

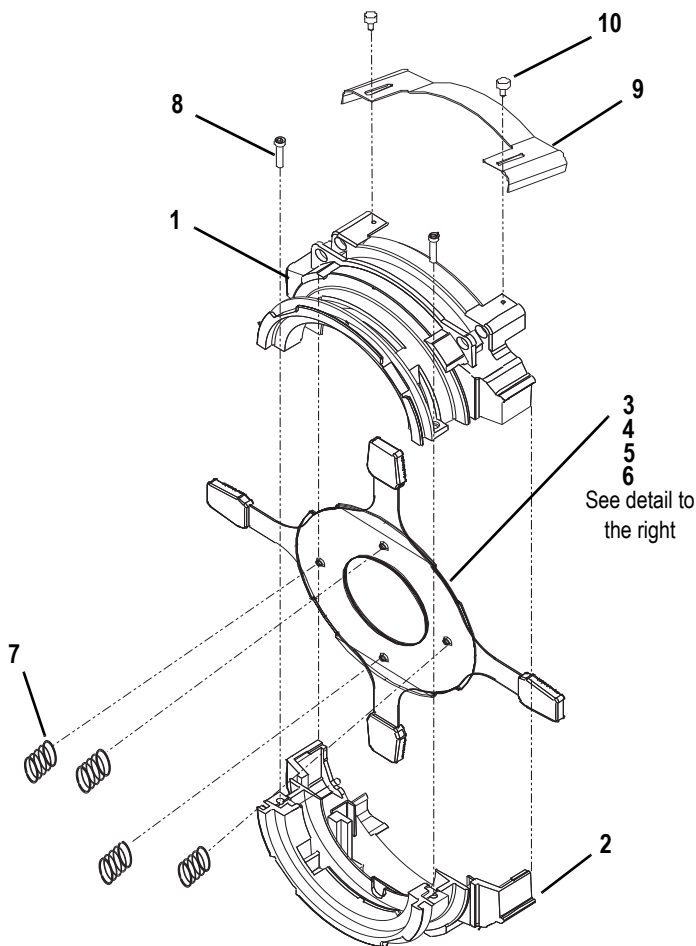

Figure 10

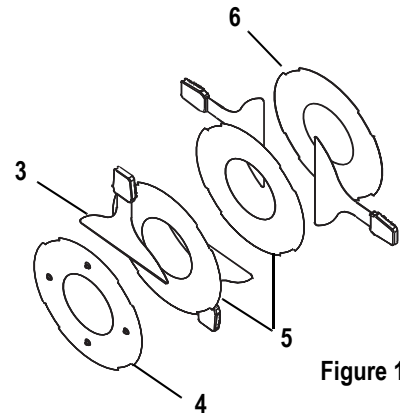

Figure 11

Shutter Assembly: The bottom divider plate (4) has four dimples punched into the surface; the top plate (6) has none. The middle divider plates (5) are noticeably thinner-gauge metal than the other two.

Reference Number	Part Number	Description	Quantity Required
1	7060A3112	Front barrel, top casting, painted	1
2	7060A3113	Front barrel, bottom casting, painted	1
3	7060A2025	Shutter blade assembly, 22 gauge	4
4	7060A3001-01	Plate, divider with dimples (bottom)	1
5	7060A3003	Plate, gate (middle)	1
6	7060A3001-02	Plate, divider (top)	1
7	HW754	Shutter spring	4
8	HW3154	Screw, 8-32 x 5/8, PhPH, taptite, black zinc	2
9	7060A3099	Cover, iris slot	1
10	HW2177	Thumb Screw, 8-32 x 1/4, black zinc	2

Assemble front barrel assembly

Tools Required:

- #2 Phillips head screwdriver



WARNING: *During assembly, the shutter springs can pop out of place. Always wear protective eyewear during this procedure.*

Step 1: See [Figure 10](#). Stand the top and bottom front barrel castings (1 and 2) upright with the shutter end of the castings toward the bottom.



Note: *The top front barrel casting (1) contains the iris slot.*

Step 2: Slide the bottom divider plate (4) into its place in the bottom casting (2). The dimples on the divider plate must point down.



Note: *The bottom divider plate (4) has four dimples punched into the surface; the top plate (6) has none. The middle divider plates (5) are noticeably thinner-gauge metal than the other two.*

The notches on the divider plates must fit against the flanges in the casting so the plates do not move.



WARNING: *Divider plate edges are sharp. Handle with caution.*

Step 3: With the bottom barrel casting (2) to your left, place one shutter blade (3) on top of dimpled divider plate (4) handle facing outward, up and down. (See [Figure 11](#)).



Note: *Install shutter blades with the rounded side facing up toward the front of the casting.*

Step 4: Place the middle gate plate (5) on top of the shutter blade.

Step 5: Place another shutter blade (3) on top of the divider plate and then place the other divider plate on top.

Step 6: Place the two shutter blades on top of the divider. Pull the blade and plate assembly slightly forward to allow the handle to slip through the slot in the bottom casting.

Step 7: Place the top divider plate (6) on top of the two shutter blades.



Note: *Make sure no shutter assembly components are under the pattern holder guides.*

Step 8: With both front barrel castings still standing upright, join the two halves, sliding the handle of the top shutter blade through the slot in the top front barrel casting (1).

Step 9: Connect the halves of the gate assembly using two PHMS screws (8). Hand tighten only (25 inch pounds).



Note: *The tops of the two front barrel castings must be even. Adjust as necessary before completely tightening the screws. Failure to do this could interfere with the barrel rotation.*

Step 10: Turn the front barrel assembly over so that the narrower end is on your work surface.

Step 11: Install the four shutter springs (7) between the four dimples in the shutter plate and the tabs in the lip of the casting.



Note: *Install the springs at the joints in the castings on either of the tabs at the joint.*

Step 12: Place iris slot cover (9) over the iris slot. Use two screws (10) to secure the cover.

15°- 30° Lens Tube

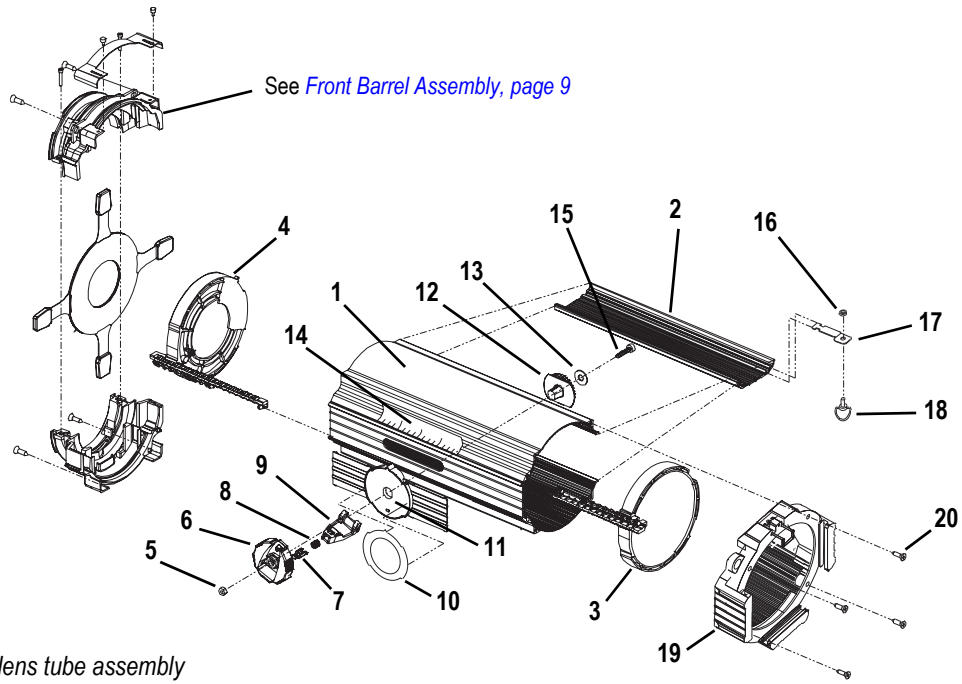

Figure 12

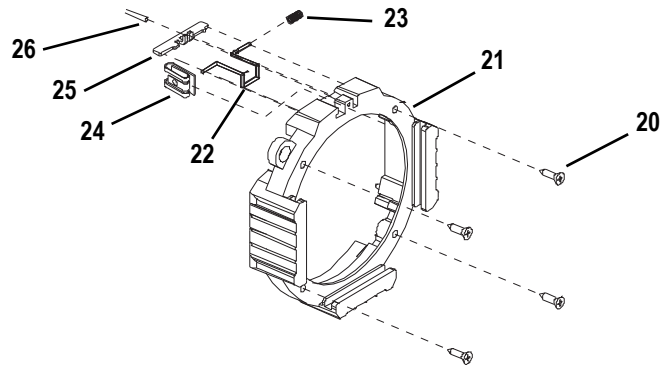

Figure 13

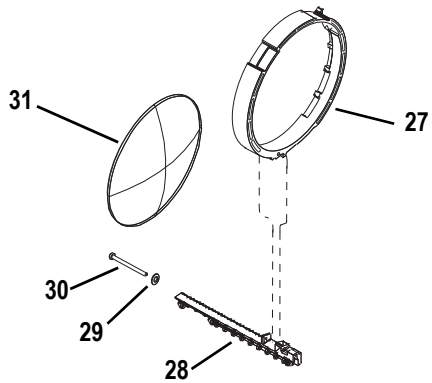

Figure 14

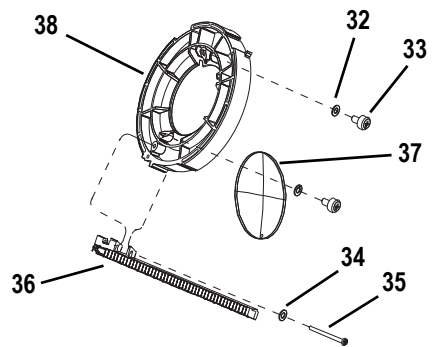

Figure 15

15°- 30° Lens tube assembly

Reference Number	Part Number	Description	Quantity Required
1	7060A2030	15°-30° lens tube	1
2	7060A3139-01	Extrusion door	1
3	See below	Front lens assembly	1
4	See below	Rear lens assembly	1
5	HW5218	Nut, 1/4-20 metal lock Lowpro	1
6	7060A4056	Dial adjustment	1
7	7060A4066	Button, push, CAM lever	1
8	HW776	Spring, push-button	1
9	7060A4057	Lever, CAM	1
10	7060A4082	Zoom field angle label	1
11	7060A4054	Light baffle	1
12	7060A4058	Gear, spur	1
13	HW777	Wash spring	1
14	7060A4081	S4 Zoom angle label, 15-30	1
15	HW5224	Screw, 1/4-20 x 1-1/4, PHMS	1
16	HW8227	Retainer, 1/4 turn stud	1
17	7060A3114	Latch bracket	1
18	HW8225	Fastener, bail style	1
19	See below	Gel frame endcap assembly	1
20	HW5217	Screw, 1/4-14 x 1, OHSL	1

15°- 30° Gel frame endcap assembly

Reference Number	Part Number	Description	Quantity Required
20	HW5217	Screw, 1/4-14 x 1, OHSL	4
21	7060A3111	Endcap, gel frame, black	1
22	7060A3100	Gel clip	1
23	HW750	Spring retainer	1
24	HW8226	Receptacle, 1/4 turn stud	1
25	7060A3097	Plate, gel clip retainer	1
26	HW3185	Screw, 8-32 x 3/8, PHPH, Taptite	1

15°- 30° Front lens assembly

Reference Number	Part Number	Description	Quantity Required
27	7060A4046	Front lens holder	1
28	7060A4050	Front gear rack	1
29	HW3118	Washer, flat #8, black	1
30	HW3114	Screw, 8-32 x 2, PHST, plastic	1
31	7060A4067	Front lens, glass	1

15°- 30° Rear lens assembly

Reference Number	Part Number	Description	Quantity Required
32	HW4117	Washer, flat, teflon	2
33	HW4112	Screw, #10-14 x 5/8, plastic	2
34	HW3118	Washer, flat #8, black	1
35	HW3114	Screw, 8-32 x 2, PHST, plastic	1
36	7060A4051	Rear gear rack	1
37	7060A4068	Rear lens glass	1
38	7060A4048	Rear lens holder	1

25°- 50° Lens Tube

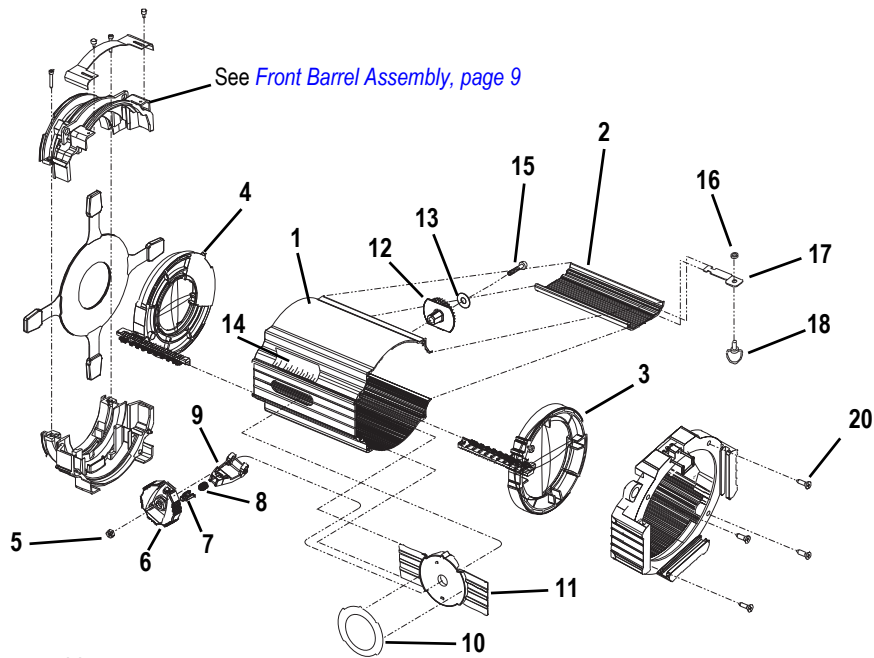

25°-50° lens tube assembly

Figure 16

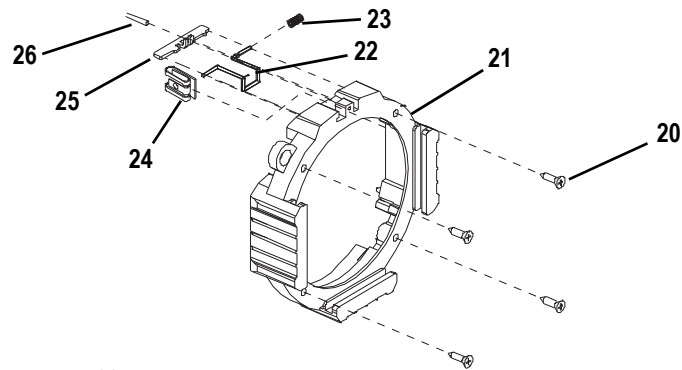

25°-50° Gel frame endcap assembly

Figure 17

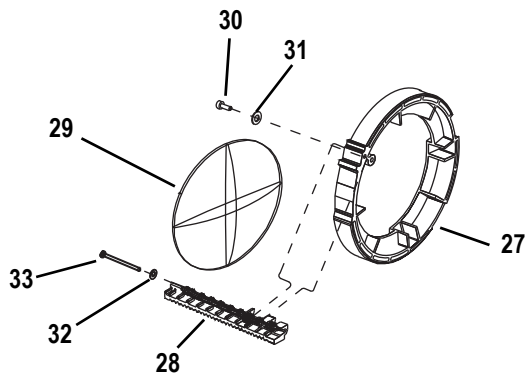

25°-50° Front lens assembly

Figure 18

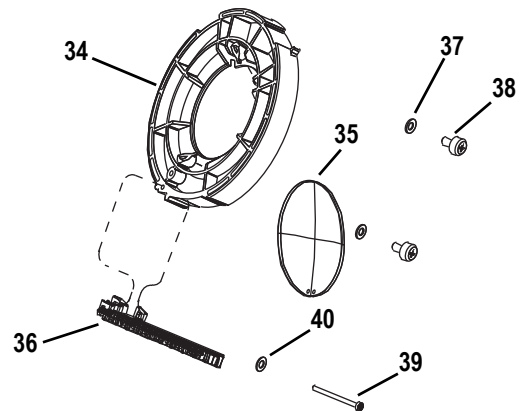

25°-50° Rear lens assembly

Figure 19

25°-50° lens tube assembly

Reference Number	Part Number	Description	Quantity Required
1	7060A2032	25°-50° lens tube	1
2	7060A3139-02	Extrusion door	1
3	See below	Front lens assembly	1
4	See below	Rear lens assembly	1
5	HW5218	Nut, 1/4-20 metal lock Lowpro	1
6	7060A4056	Dial adjustment	1
7	7060A4066	Button, push, CAM lever	1
8	HW776	Spring, push-button	1
9	7060A4057	Lever, CAM	1
10	7060A4084	Zoom field angle label	1
11	7060A4055	Light baffle	1
12	7060A4058	Gear, spur	1
13	HW777	Wash spring	1
14	7060A4080	S4 Zoom angle label, 15-30	1
15	HW5224	Screw, 1/4-20 x 1-1/4, PHMS	1
16	HW8227	Retainer, 1/4 turn stud	1
17	7060A3114	Latch bracket	1
18	HW8225	Fastener, bail style	1
19	See below	Gel frame endcap assembly	1
20	HW5217	Screw, 1/4-14 x 1, OHSL	1

25°- 50° Gel frame endcap assembly

Reference Number	Part Number	Description	Quantity Required
20	HW5217	Screw, 1/4-14 x 1, OHSL	4
21	7060A3111	Endcap, gel frame, black	1
22	7060A3100	Gel clip	1
23	HW750	Spring retainer	1
24	HW8226	Receptacle, 1/4 turn stud	1
25	7060A3097	Plate, gel clip retainer	1
26	HW3185	Screw, 8-32 x 3/8, PHPH, Taptite	1

25°- 50° Front lens assembly

Reference Number	Part Number	Description	Quantity Required
27	7060A4047	Front lens holder	1
28	7060A4052	Front gear rack	1
29	7060A4069	Front lens, glass	1
30	HW4112	Screw, #10-10 x 5/8, plastic	1
31	HW4117	Washer, flat, teflon	1
32	HW3118	Washer, flat #8, zinc	1
33	HW3114	Screw, 8-32, PHST, plastic	1

25°- 50° Rear lens assembly

Reference Number	Part Number	Description	Quantity Required
34	7060A4048	Rear lens holder	1
35	7060A4070	Rear lens glass	1
36	7060A4053	Rear gear rack	1
37	HW4117	Washer, flat, teflon	2
38	HW4112	Screw, #10 - 10 x 5/8, plastic	2
39	HW3116	Screw, 8-10 x 1-1/2	1
40	HW3118	Washer, flat #8, zinc	1

Assemble lens tube (15°-30° and 25°-50°)

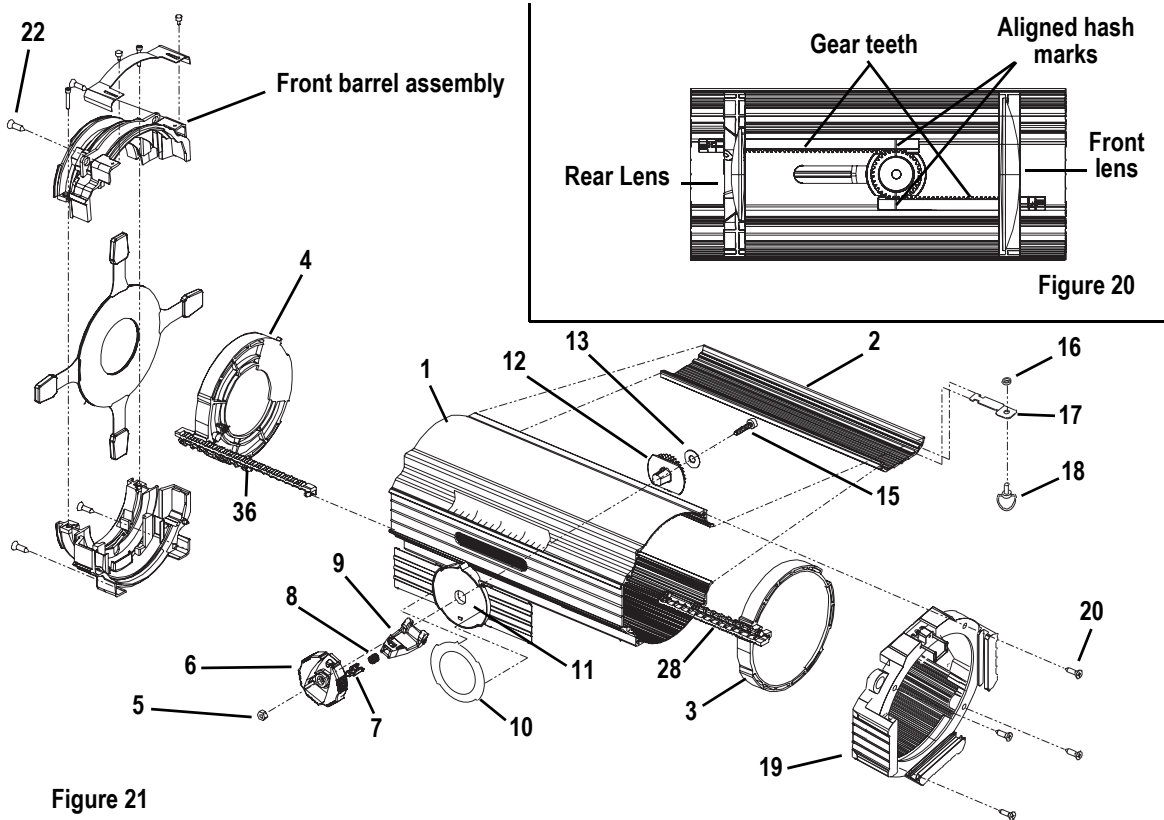

Figure 21

Tools Required:

- #2 Phillips head screwdriver

- Step 1: Slide the front lens assembly (3) and rear lens assembly (4) into the lens tube (1) as shown in [Figure 20](#).
- Step 2: Position the lens assembly gear teeth as shown in [Figure 20](#).
- Step 3: From inside the unit, place the gear spur (12) between the lens assemblies. Make sure the vertical hash marks on the gear spur line up with the hash marks on both the front and rear gear teeth. See [Figure 20](#).
- Step 4: Slide the light baffle (11) into the opening of the lens tube. See [Figure 21](#).
- Step 5: From inside the unit, pass the screw (15) through the washer (13), the hole on the gear spur (12) and the light baffle (11).
- Step 6: On the outside of the unit, place the adjustment dial (6) over the screw end (15) and secure with the metal nut (5).
- Step 7: Place the front barrel assembly onto the rear of the lens tube and secure with four screws (22).
- Step 8: With the extrusion door open, place the gel cap (19) on the front of the unit and secure with four screws (20).
- Step 9: Once the gel cap is in place, close the extrusion door and turn the fastener (18) one-quarter turn clockwise to secure the baffle in place.

Cleaning glass lens



WARNING: *Do not use ammonia-based or other harsh commercial cleaners. Clean lens only as directed.*

Commercially available glass cleaning agents should be avoided as they may contain ammonia, other harsh chemical detergents or abrasive agents. These cleaners may damage the glass surface and the Anti-Reflective coatings. Do not immerse or soak the glass in any cleaning solution.

Remove dust with a blast of oil-free air or wipe with a clean, lint-free cloth. Isopropyl alcohol, distilled water or a 50%-50% mixture of each can be used to clean the glass surface.



Corporate Headquarters ■ 3031 Pleasant View Road, P.O. Box 620979, Middleton, Wisconsin 53562-0979 USA ■ Tel +608 831 4116 ■ Fax +608 836 1736
London, UK ■ Unit 26-28, Victoria Industrial Estate, Victoria Road, London W3 6UU, UK ■ Tel +44 (0)20 8896 1000 ■ Fax +44 (0)20 8896 2000
Rome, IT ■ Via Ennio Quirino Visconti, 11, 00193 Rome, Italy ■ Tel +39 (06) 32 111 683 ■ Fax +39 (06) 32 656 990
Holzkirchen, DE ■ Ohmstrasse 3, 83607 Holzkirchen, Germany ■ Tel +49 (80 24) 47 00-0 ■ Fax +49 (80 24) 47 00-3 00
Hong Kong ■ Rm 1801, 18/F, Tower 1 Phase 1, Enterprise Square, 9 Sheung Yuet Road, Kowloon Bay, Kowloon, Hong Kong ■ Tel +852 2799 1220 ■ Fax +852 2799 9325
Service: (Americas) service@etcconnect.com ■ (UK) service@etc europe.com ■ (DE) techserv-hoki@etcconnect.com ■ (Asia) service@etcasia.com
Web: www.etcconnect.com ■ Copyright © 2007 ETC. All Rights Reserved. ■ Product information and specifications subject to change.
7060M2550-06.01 ■ Rev A ■ Released 08/2007