

# *insight 2*

**Lighting control system**

*Version 2.0*



# *insight 2*

**Lighting control system**

Version 2.0

## ***User Manual***

Copyright 1994-96 Electronic Theatre Controls  
4071M1001 Revised May 1996

# Limited Warranty

Electronic Theatre Controls (ETC) warrants to the original owner or retail customer that for a period of one year from date of delivery of a portable system or energization of a permanently installed system (up to a maximum of 18 months from delivery) its products will be free from defects in materials and workmanship under normal use and service. Warranty is limited to 90 days for rental equipment.

Warranty does not cover any product or part of a product subject to accident, negligence, alteration, abuse or misuse or any accessories or parts not supplied by ETC. Warranty does not cover "consumable" parts such as fuses, lamps, color media or components warranted directly to the owner by the original manufacturer. ETC's warranty does not extend to items not manufactured by us. Freight terms on warranty repairs are FOB ETC factory or designated repair facility. Collect shipments or freight allowances will not be accepted.

ETC's sole responsibility under this warranty shall be to repair or replace at ETC's option such parts as shall be determined to be defective on ETC's inspection. ETC will not assume any responsibility for any labor expended or materials used to repair any equipment without ETC's prior written authorization. ETC shall not be responsible for any incidental, general or consequential damages, damages to property, damages for loss of use, time, profits or income, or any other damages.

The owner's obligations during the warranty period under this warranty are to notify ETC at ETC's address within one week of any suspected defect, and to return the goods prepaid to ETC at their factory or authorized service center.

THIS WARRANTY IS CONTINGENT ON THE CUSTOMER'S FULL AND TIMELY COMPLIANCE WITH THE TERMS OF PAYMENT SET FORTH IN THE "TERMS AND CONDITIONS". THIS WARRANTY IS EXPRESSLY IN LIEU OF ANY AND ALL OTHER WARRANTIES EXPRESSED OR IMPLIED INCLUDING THE WARRANTIES OF MERCHANTABILITY AND FITNESS FOR A PARTICULAR PURPOSE AND OF OTHER OBLIGATIONS AND LIABILITIES ON OUR PART. THE OWNER ACKNOWLEDGES THAT NO OTHER REPRESENTATIONS WERE MADE TO HIM OR RELIED UPON HIM WITH RESPECT TO THE QUALITY AND FUNCTION OF THE GOODS SOLD.

This written warranty is intended as a complete and exclusive statement of the terms thereof. Prior dealings or trade usage shall not be relevant to modify, explain or vary this warranty. Acceptance of, or acquiescing in, a course of performance under this warranty shall not modify the meaning of this agreement even though either party has knowledge of the performance and a chance to object.

## Declaration of Conformity

**Manufacturer's Name:** Electronic Theatre Controls, Inc.  
**Manufacturer's Address:** 3030 Laura Lane  
Middleton, WI 53562 USA



declares that the product

**Product name:** Expression 2 lighting control console  
**Model:** Expression 2x, Concept 2x, Insight 2x, Insight 2, Impression 2, Lighting Playback Controller  
**Product Options** This declaration covers all options of the above products.

conforms to the following product specifications:

Safety: EN 60950  
EMC: CISPR 22/EN55022 Class B  
IEC 801-2:1984/IEC 1000-4-2:1995-01 8KV AD  
IEC 801-3:1984/ENV 50140, ENV 50204:1993 3 V/M 26-1000 MHz  
IEC 801-4:1988/IEC 1000-4-4:1995-01 .5kV Sig. Lines 1kV power line

### Supplementary information:

The products herewith comply with the requirements of the Low Voltage Directive 73/23/EEC and the EMC Directive 89/336/EEC, as amended by Directive 92/31/EEC.

Middleton, Wisconsin, USA 25 April 1995

  
Jonathan R. Ide/Vice President of Research and Development

European contact: Your local ETC Technical Services office, or ETC Ltd, 5 Victoria Industrial Estate, Victoria Road, London W3 6UU, UK, Tel: (+44) 181 896 1000 Fax: (+44) 181 896 2000

# table of contents

## **Chapter 1**

|                                |   |
|--------------------------------|---|
| <b>Introduction</b> .....      | 1 |
| Troubleshooting .....          | 2 |
| Using this manual .....        | 3 |
| Using Help .....               | 3 |
| Text conventions .....         | 3 |
| Output level conventions ..... | 3 |
| About Show .....               | 4 |

## **Chapter 2**

|                               |    |
|-------------------------------|----|
| <b>Monitor displays</b> ..... | 5  |
| Channel colors .....          | 6  |
| Changing pages .....          | 6  |
| Stage .....                   | 7  |
| Blind .....                   | 8  |
| Fader .....                   | 9  |
| Flexichannel .....            | 10 |
| Tracksheet .....              | 11 |
| Patch .....                   | 12 |
| Park .....                    | 13 |

## **Chapter 3**

|  |    |
|--|----|
| <b>System settings</b> .....               | 15 |
| Setting number of dimmers .....            | 16 |
| Setting number of channels .....           | 16 |
| Setting default fade times .....           | 17 |
| Setting default Level .....                | 18 |
| Setting default fader clear time .....     | 18 |
| Setting default Sneak time .....           | 19 |
| Setting Designer's Worksheet options ..... | 20 |
| Enable/disable Blackout key .....          | 21 |
| Enable/disable Flexichannel .....          | 22 |
| Set Master type .....                      | 23 |
| Set Channels/Submasters 1-to-1 .....       | 23 |
| Setting time format .....                  | 24 |
| Record Lockout .....                       | 24 |
| Enable/disable Bump keys .....             | 25 |
| Setting clock .....                        | 26 |
| Naming show .....                          | 27 |

## **Chapter 4**

|   |    |
|---|----|
| <b>Patch</b> .....                          | 29 |
| Selecting one-to-one patch .....            | 30 |
| Creating custom patch .....                 | 30 |
| Patching dimmers to channels .....          | 31 |
| Proportional patching .....                 | 32 |
| Unpatching individual dimmers .....         | 33 |
| Labeling dimmers .....                      | 34 |
| Assigning a profile to a dimmer .....       | 35 |
| Capturing channels in Patch .....           | 36 |
| Dimmer check .....                          | 37 |
| About .....                                 | 38 |
| About Dimmer .....                          | 38 |
| About Dimmer with ETCLink .....             | 39 |
| Multiplexed dimmers .....                   | 40 |
| Patching to a Strand CD80 dimmer rack ..... | 41 |

## **Chapter 5**

|   |    |
|---|----|
| <b>Setting channel levels</b> .....           | 43 |
| Channel modes .....                           | 44 |
| Captured channels .....                       | 44 |
| Selected channels .....                       | 44 |
| Recorded channels .....                       | 44 |
| Moving channels .....                         | 44 |
| Tracked channels .....                        | 44 |
| Channel Attributes display .....              | 45 |
| Independent channels .....                    | 46 |
| Flipped channels .....                        | 47 |
| Labeling a channel .....                      | 48 |
| Selecting channels .....                      | 49 |
| Selecting channels in Flexichannel mode ..... | 49 |
| Setting channel levels .....                  | 50 |
| Level wheel .....                             | 50 |
| Full .....                                    | 50 |
| Level .....                                   | 50 |
| Flash .....                                   | 50 |
| Sneak .....                                   | 51 |
| Channel check .....                           | 52 |
| About .....                                   | 53 |
| About Channel .....                           | 53 |

## **Chapter 6**

|                                       |    |
|---------------------------------------|----|
| <b>Cues</b> .....                     | 55 |
| Cue types .....                       | 56 |
| Crossfade .....                       | 56 |
| Allfade .....                         | 56 |
| Subroutine .....                      | 56 |
| Effects .....                         | 56 |
| Record functions .....                | 57 |
| Creating cues .....                   | 58 |
| Viewing cues .....                    | 58 |
| Working with cues in Stage mode ..... | 59 |
| Recording a cue in Stage .....        | 60 |
| Working with cues in Blind mode ..... | 61 |
| Recording a cue in Blind .....        | 62 |

|  |    |
|--|----|
| Recording a cue with a single fade time . . . . .            | 63 |
| Recording a cue with split fade times . . . . .              | 64 |
| Recording a cue with a wait time . . . . .                   | 65 |
| Recording cues with Link and Follow . . . . .                | 66 |
| Link . . . . .   | 66 |
| Follow . . . . .   | 66 |
| Combining Link and Follow to create playback loops . . . . . | 67 |
| Using Link to link a macro to a cue . . . . .                | 67 |
| Recording a cue using Solo . . . . .                         | 68 |
| Labeling cues . . . . .                                      | 69 |
| Modifying a recorded cue live . . . . .                      | 70 |
| Modifying channels in a cue . . . . .                        | 70 |
| Modifying cue attributes . . . . .                           | 70 |
| Using Update to modify channels in a cue . . . . .           | 71 |
| Using Update to add channels to a cue . . . . .              | 72 |
| Using Update to modify fade rate . . . . .                   | 73 |
| Deleting cues . . . . .                                      | 74 |
| Copying cues . . . . .                                       | 74 |
| Inserting cues . . . . .                                     | 75 |
| Cue List . . . . .   | 76 |

**Chapter 7**

|   |    |
|---|----|
| <b>Track</b> . . . . .                  | 79 |
| Track record . . . . .                  | 80 |
| Using record to create tracks . . . . . | 81 |
| Recording modified cues . . . . .       | 82 |
| Inserting cues . . . . .                | 84 |
| Blackout cues and tracking . . . . .    | 86 |
| Tracksheet . . . . .                    | 88 |

**Chapter 8**

|  |    |
|--|----|
| <b>Multipart cues</b> . . . . .                        | 91 |
| Recording a multipart cue . . . . .                    | 92 |
| Converting a standard cue to a multipart cue . . . . . | 93 |
| Wait times in multipart cues . . . . .                 | 94 |
| Editing a multipart cue . . . . .                      | 94 |
| Deleting a part from a multipart cue . . . . .         | 94 |
| Adding, deleting and modifying channels . . . . .      | 95 |
| Modifying fade and wait times . . . . .                | 96 |

**Chapter 9**

|   |     |
|---|-----|
| <b>Playing back cues</b> . . . . .      | 97  |
| Selecting cues . . . . .                | 98  |
| Timed faders and LED displays . . . . . | 99  |
| Clearing faders . . . . .               | 99  |
| Cue List . . . . .                      | 100 |
| Fader Status display . . . . .          | 101 |
| Selecting and playing a cue . . . . .   | 102 |
| Go . . . . .                            | 102 |
| Hold . . . . .                          | 102 |
| Back . . . . .                          | 103 |
| Go to a different cue . . . . .         | 103 |
| Controlling fades manually . . . . .    | 104 |
| Manual override . . . . .               | 104 |
| Rate override . . . . .                 | 105 |
| Quickstep . . . . .                     | 106 |

## **Chapter 10**

|  |     |
|--|-----|
| <b>Groups</b> .....                                      | 107 |
| Creating groups .....                                    | 108 |
| Creating a group from the look on stage .....            | 108 |
| Creating a group using Solo .....                        | 109 |
| Displaying groups on stage .....                         | 110 |
| Working with groups in Blind .....                       | 111 |
| Group mode .....   | 111 |
| Group Editing mode .....                                 | 111 |
| Modifying groups .....                                   | 112 |
| In Blind .....   | 112 |
| In Stage .....   | 113 |
| Using Update to modify groups .....                      | 114 |
| Labeling groups .....                                    | 116 |
| Deleting groups .....                                    | 117 |
| Copying groups .....                                     | 117 |
| Using cues or submasters as groups .....                 | 118 |
| Using groups to modify cues or submasters in Blind ..... | 119 |
| Only .....   | 120 |
| Group List .....   | 121 |

## **Chapter 11**

|  |     |
|--|-----|
| <b>Submasters</b> .....  | 123 |
| Submaster types .....  | 124 |
| Pile-on submaster .....  | 124 |
| Inhibitive submaster .....   | 124 |
| Effect submaster .....   | 124 |
| Changing type .....  | 125 |
| Submaster pages .....  | 126 |
| Submaster LEDs .....   | 127 |
| Submaster bump buttons .....   | 128 |
| Bump button status .....   | 128 |
| Bump button mode .....   | 129 |
| Recording submasters .....   | 130 |
| Fade and dwell times for submasters .....  | 130 |
| Adding a rate to a submaster .....   | 133 |
| Specifying a submaster's page .....  | 133 |
| Using Except to record a submaster without another<br>submaster's channels ..... | 134 |
| Creating inhibitive submasters .....   | 135 |
| Modifying submasters in Blind .....  | 136 |
| Modifying submasters in Stage .....  | 136 |
| Using Update to modify submasters .....  | 137 |
| Live control of a submaster's rate .....   | 138 |
| Controlling submaster fades manually .....                                       | 138 |
| Labeling submasters .....  | 139 |
| Copying submasters .....   | 139 |
| Loading cues or groups to submasters .....                                       | 140 |
| Copying cues or groups to submasters .....                                       | 140 |
| Clearing submasters .....  | 141 |
| Submaster List .....   | 142 |

## **Chapter 12**

|                                    |     |
|------------------------------------|-----|
| <b>Effects</b> .....               | 145 |
| Steps .....                        | 146 |
| Creating steps .....               | 147 |
| Default element assignment .....   | 149 |
| Controlling effects .....          | 150 |
| Attributes .....                   | 150 |
| Effect fade times .....            | 152 |
| Using a random rate .....          | 154 |
| Modifying effects .....            | 155 |
| Inserting steps .....              | 155 |
| Deleting steps .....               | 156 |
| Editing step characteristics ..... | 156 |
| Running an effect cue .....        | 158 |
| Using an effect submaster .....    | 158 |

## **Chapter 13**

|                             |     |
|-----------------------------|-----|
| <b>Subroutines</b> .....    | 159 |
| Steps .....                 | 160 |
| Cue steps .....             | 160 |
| Crossfade .....             | 160 |
| Allfade .....               | 160 |
| Style steps .....           | 161 |
| Subroutine attributes ..... | 161 |
| Creating subroutines .....  | 162 |
| Editing a subroutine .....  | 164 |
| Deleting a step .....       | 164 |
| Inserting a step .....      | 164 |

## **Chapter 14**

|                                  |     |
|----------------------------------|-----|
| <b>Macros</b> .....              | 165 |
| Creating macros .....            | 166 |
| Using Learn .....                | 166 |
| Using Macro display mode .....   | 168 |
| Next macro .....                 | 169 |
| Macro wait .....                 | 169 |
| Linking macros .....             | 170 |
| Using submasters in macros ..... | 171 |
| Playing macros .....             | 172 |
| Canceling a macro .....          | 172 |
| Powerup macro .....              | 172 |
| Modifying macros .....           | 173 |
| Clearing macros .....            | 173 |
| Copying macros .....             | 174 |
| Sample macros .....              | 175 |

## **Chapter 15**

|                                    |     |
|------------------------------------|-----|
| <b>Diskette functions</b> .....    | 177 |
| Diskette management .....          | 178 |
| Formatting diskettes .....         | 179 |
| Recording a show on diskette ..... | 180 |
| Reading a show from diskette ..... | 181 |

## **Chapter 16**

|                          |     |
|--------------------------|-----|
| <b>Printing</b> .....    | 183 |
| Printer options .....    | 184 |
| Stage display .....      | 184 |
| Cues .....               | 185 |
| Groups .....             | 186 |
| Submasters .....         | 187 |
| Cue List .....           | 188 |
| Group List .....         | 188 |
| Submaster List .....     | 189 |
| Macros .....             | 190 |
| Patch .....              | 191 |
| Channel Attributes ..... | 191 |
| Real Time Programs ..... | 192 |
| SMPTE events .....       | 192 |
| Tracksheet .....         | 193 |

## **Chapter 17**

|                              |     |
|------------------------------|-----|
| <b>Clear functions</b> ..... | 195 |
| Clear functions .....        | 196 |
| Show .....                   | 197 |
| Cues .....                   | 197 |
| Groups .....                 | 197 |
| Submasters .....             | 198 |
| Show and Patch .....         | 198 |
| Designer's Worksheet .....   | 199 |
| Macros .....                 | 199 |
| Reset 1-to-1 Patch .....     | 200 |
| Channel Attributes .....     | 200 |
| Real Time Programs .....     | 201 |
| SMPTE .....                  | 201 |
| Reset system .....           | 202 |

## **Chapter 18**

|  |     |
|--|-----|
| <b>Accessories</b> .....                         | 203 |
| Remote Focus Unit (RFU) .....                    | 204 |
| Infrared Remote Focus Unit (IRFU) .....          | 205 |
| Designer's Worksheet .....                       | 207 |
| Using the Designer's Worksheet .....             | 207 |
| Programming regions .....                        | 208 |
| Macro Wait .....                                 | 209 |
| Copying regions .....                            | 210 |
| Clearing regions .....                           | 211 |
| Alphanumeric keyboard .....                      | 212 |
| Naming cues, submasters, groups, and shows ..... | 212 |
| Naming shows .....                               | 212 |

## **Chapter 19**

|  |     |
|--|-----|
| <b>Sensor dimming</b> .....            | 213 |
| Enabling ETCLink .....                 | 214 |
| Enabling ETCLink messages .....        | 214 |
| Monitoring dimmers .....               | 215 |
| Recording dimmer loads .....           | 216 |
| Checking dimmer loads .....            | 217 |
| Clearing dimmer loads .....            | 219 |
| Load errors .....                      | 220 |
| Sensor dimming system status .....     | 221 |
| Dimmer rack status .....               | 222 |
| Dimmer status .....                    | 223 |
| Setting and unsetting dimmers .....    | 224 |
| Working with Sensor backup looks ..... | 225 |
| Recording a backup look .....          | 225 |
| Playing a backup look .....            | 226 |
| Error messages .....                   | 227 |

## **Chapter 20**

|                                      |     |
|--------------------------------------|-----|
| <b>Control interfaces</b> .....      | 229 |
| MIDI .....                           | 230 |
| ETC MIDI .....                       | 230 |
| MIDI Show Control (MSC) .....        | 234 |
| Real time clock .....                | 238 |
| DMX512 input .....                   | 242 |
| SMPTE .....                          | 244 |
| Enabling SMPTE input .....           | 245 |
| Creating SMPTE programs .....        | 246 |
| Editing SMPTE programs .....         | 251 |
| Playing back the SMPTE program ..... | 257 |
| Remote macros .....                  | 260 |
| Remote trigger .....                 | 261 |

## **Chapter 22**

|   |     |
|---|-----|
| <b>Park</b> .....                         | 263 |
| Parking dimmers .....                     | 264 |
| Unparking dimmers .....                   | 265 |
| Parking channels .....                    | 266 |
| Unparking channels .....                  | 267 |
| Parking groups, cues and submasters ..... | 268 |
| Unpark a group, cue or submaster .....    | 269 |
| Park display .....                        | 270 |

|  |     |
|--|-----|
| <b>Appendix A</b>                      |     |
| <b>Installation</b>                    | 271 |
| Insight 2 back panel                   | 272 |
| DIP switches and jumpers               | 273 |
| Circuit boards                         | 274 |
| Main Processor Board - Revision 0 or B | 274 |
| Node Board - Revision A                | 275 |
| Installing console and monitor         | 276 |
| Older console DIP switch settings      | 277 |
| Connecting dimmers                     | 278 |
| Replacing the auxiliary fuse           | 278 |
| System configuration                   | 279 |
| Setting DMX512 starting numbers        | 279 |
| Setting Multiplex mode                 | 280 |
| Setting DMX512 speed                   | 280 |
| Updating Insight 2 software            | 281 |
| Installing an alphanumeric keyboard    | 282 |
| Installing a printer                   | 283 |
| Installing Designer's Worksheet        | 284 |
| Installing the Kurta XGT               | 284 |
| Installing the Kurta IS/ONE            | 286 |
| Installing Remote Focus Unit           | 288 |
| Installing MIDI                        | 289 |
| Installing SMPTE                       | 291 |
| ETCNet                                 | 292 |
| Installing Remote Interfaces           | 294 |
| Installing Remote Video Interface      | 296 |
| Installing remote unit software        | 299 |
| Installing remote video monitors       | 300 |
| Installing Infrared Remote Focus Unit  | 301 |
| Installing remote macros               | 302 |
| <b>Appendix B</b>                      |     |
| <b>Error messages</b>                  | 305 |
| Diskette error messages                | 305 |
| Other error messages                   | 306 |
| ETCLink errors                         | 307 |
| <b>Appendix C</b>                      |     |
| <b>Specifications</b>                  | 309 |
| <b>Appendix D</b>                      |     |
| <b>Reference</b>                       | 313 |
| <b>Appendix E</b>                      |     |
| <b>Softkeys</b>                        | 349 |
| <b>Index</b>                           | 353 |

# *chapter 1*

## *introduction*

This chapter includes information to orient you to the console and the manual. It includes the following sections:

- Troubleshooting
- Using this manual
- Using Help
- Text conventions
- Output level conventions
- About Show

# ***Troubleshooting***

If you have problems with your console, please refer to the manual or the console's Help function for instructions. (For more information about using Help, see page 3.)

If you do not find the answer in the manual, call your local dealer or ETC Technical Services. Please have the following information available before you call:

- Console model and serial number (located on back panel)
- Software version (displayed on Setup menu)
- Options installed
- Dimmer installation type
- Dimmer manufacturer

To reach the ETC Technical Services department, call one of the numbers shown below. After hours and weekend calls are answered electronically and forwarded to a service representative.

## **U.S.**

Electronic Theatre Controls, Inc.  
Technical Services Department  
3030 Laura Lane  
Middleton, WI 53562

Monday through Friday, 8:00 AM to 6:00 PM CST  
800/775-4382  
608/831-4116

## **Europe**

ETC Europe Ltd.  
Technical Services Department  
5 Victoria Industrial Estate  
Victoria Road, London W3 6UU

(+44) 181 896 1000

## **Asia**

ETC Asia, Ltd.  
Technical Services Department  
Room 1619-20, Metro Centre II, 21 Lam Hing Street  
Kowloon Bay, Kowloon, Hong Kong

(+852) 2799 9325

## ***Using this manual***

This manual provides instructions for using Insight 2's features and optional accessories.

### ***Setting up Insight 2***

If you are setting up the system for the first time, chapters 4 and 5 and appendix A instruct you in installing and configuring Insight 2. If the system is already in place, you may not need to refer to these chapters.

### ***New users***

If you are new to lighting consoles, or to Insight 2 in particular, read chapters 5 through 11 for instructions on setting channel levels and using cues, groups, and submasters. These are the building blocks for creating and running any show. Once you are comfortable with these functions, chapters 12 through 22 provide more advanced information on effects, subroutines, and macros.

### ***Experienced users***

Once you are familiar with the system, refer to *Appendix D, Glossary*, and the console's Help function for answers to any remaining questions you may have.

## ***Using Help***

Help screens are available for all Insight 2 keys, including softkeys and wheels. To display help screens, press [Help], then press any key on the console.

## ***Text conventions***

In this manual, console keys are indicated by square brackets, such as [Enter]. Messages that appear on the console displays are printed in boldface, such as **Select channel**. References to other sections of the manual are printed in italics, such as *Chapter 1, Introduction*.

## ***Output level conventions***

In almost every case, Insight 2 uses a highest level, or pile-on, convention to determine levels for channels affected by more than one output. Insight 2 reads all output levels it receives for a specific channel and sets that channel to the highest one. A level setting entered on the keypad, however, takes priority over almost any other input.

For example, if a channel is included in both a submaster and a cue that has played back and is in a fader, Insight 2 sets the channel at the higher of the two levels. You may then use the keypad to select that channel and set it to any level, regardless of the levels set by the cue and the submaster.

## About Show

About Show provides you with memory usage information regarding the currently loaded show. It tells you how many channels and dimmers your show is configured for, and how many of the available cues, submasters, groups, macros and SMPTE events you are using. It also indicates the percentage of the console's available memory used for each function.

Press [About] [Enter] to display the **About Show** window.

*Note: There is not enough memory to record the maximum number of all functions at the same time. Use About Show to monitor your memory usage as the complexity of your show increases. If you fill the available memory, you can reclaim it by clearing cues, groups, subs, macros, or events that you are no longer using.*

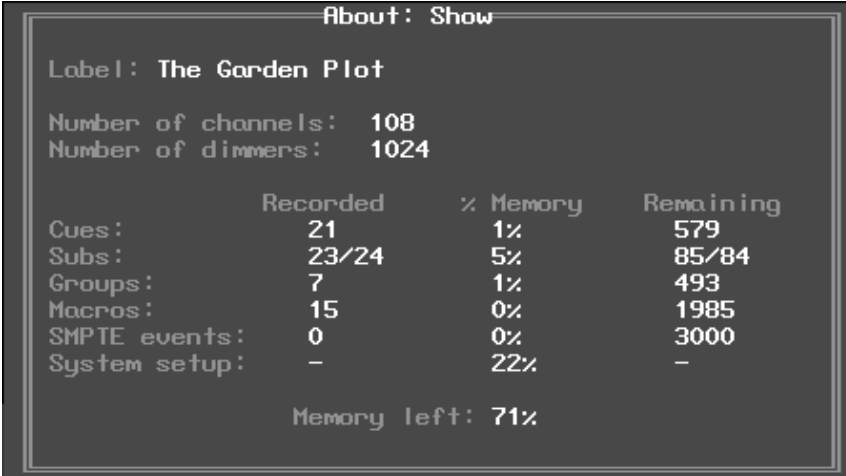

The screenshot shows a window titled "About: Show" with a dark background and light text. It displays the following information:

|                     | Recorded        | % Memory | Remaining |
|---------------------|-----------------|----------|-----------|
| Label:              | The Garden Plot |          |           |
| Number of channels: | 108             |          |           |
| Number of dimmers:  | 1024            |          |           |
| Cues:               | 21              | 1%       | 579       |
| Subs:               | 23/24           | 5%       | 85/84     |
| Groups:             | 7               | 1%       | 493       |
| Macros:             | 15              | 0%       | 1985      |
| SMPTE events:       | 0               | 0%       | 3000      |
| System setup:       | -               | 22%      | -         |
| Memory left: 71%    |                 |          |           |

The **Memory left** indicator shows you how much console memory is still available to record additional functions. Insight 2 allows you to record up to 600 cues, 500 groups, 2,000 macros, and 3,000 SMPTE events as available memory permits.

*Note: The console software uses approximately 15-20 percent of the available memory to store setup options and other console information, shown above as **System setup**.*

# chapter 2

## monitor displays

Insight 2 provides a color video monitor. This display provides information regarding your show, including a cue list, the current status of the console's two fader pairs, and a variety of user selectable displays. These displays allow you to create and run shows and to configure your console and your lighting system.

If your system includes an ETCNet network, additional monitors may be installed at other locations, such as backstage or in the sound booth. These remote monitors show the same displays as the console's monitor. See *Appendix A, Installation*, for information about installing remote monitors.

This chapter includes descriptions of the following displays:

- Stage
- Blind
- Fader
- Flexichannel
- Tracksheet
- Patch
- Park
- Playback

## Channel colors

The colors in which channel numbers and output levels are displayed on screen provide information about the channels. The following chart shows the meaning of colors in Stage, Blind, Fader, and Tracksheet display modes. Information on the use of colors in other display modes are included in their sections of this chapter.

### Channel numbers

- Gray**..... Unselected channel.
- Yellow**..... Selected channel. Controlled by the wheel when [Enter] is pressed, or when you move the wheel.
- White**..... Channel not selected by Only function.

### Channel output levels

- White on Red**.. Selected channel. Level instructions from the keypad or the wheel affect this channel's level.
- Yellow**..... Channel output level was set by a submaster.
- White**..... Channel output level was set by an effect.  
In Tracksheet and Blind, white channel levels were set by an Allfade cue.
- Gray**..... Channel was recorded into a multipart cue, but not in the currently displayed part (Blind only).
- Red**..... Channel has been de-selected, but its current level was established using the keypad.
- Green**..... Channel output level is changed from what it was in the previous cue. In Tracksheet and Blind only, channel output is lower than it was in the previous cue.
- Magenta**..... Channel output level is the same as it was in the previous cue (tracking).
- Blue**..... In Tracksheet and Blind only, channel output level is higher than it was in the previous cue.

## Changing pages

[S4], **Previous Page**, and [S5], **Next Page**, softkeys allow you to change pages on many displays. The arrow keys may also be used to switch from page to page. Pressing [←] takes you to the first page, pressing [↑] takes you to the previous page, pressing [↓] takes you to the next page, and pressing [→] takes you to the final page.

# Stage

The Stage display shows you the current levels of all active channels. Up to 125 channels can appear on the display at a time.

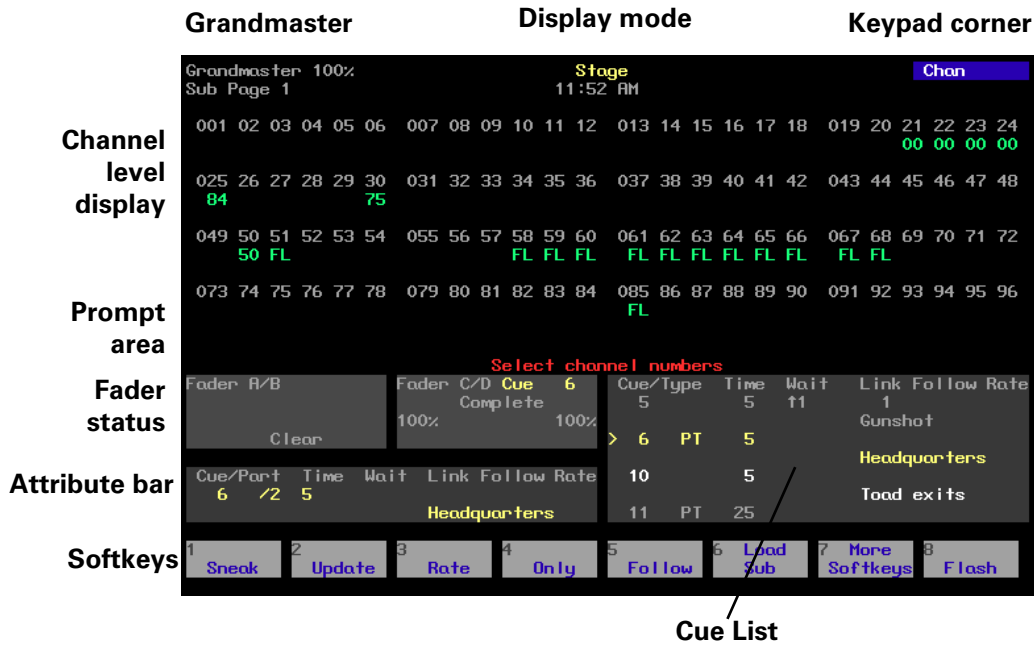

## Grandmaster

Current Grandmaster setting, Blackout alert and submaster page.

## Display mode

Current display mode and time

## Keypad corner

Indicates how the console will interpret the next number entered from the keypad. For example, if you press [Channel], the corner displays **Chan**, indicating that the console will read the next number as a channel number. If you enter a range, only the last number in the range will appear.

## Channel level display

Current level of all channels.

## Prompt area

Information and prompts appear here.

## Fader status

Indicates current status of both fader pairs. Shows cue running in fader, fade times, percentage of completion, and follow times.

## Attribute bar

Shows current settings for selected cue, group or submaster.

## Softkeys

Stage functions for [S1] through [S8].

## Cue List

Lists all cues along with their attributes. The next cue in the cue list is yellow. This can be changed from Stage mode, but not from Blind.

# Blind

The Blind display lets you work on cues without affecting the look on stage.

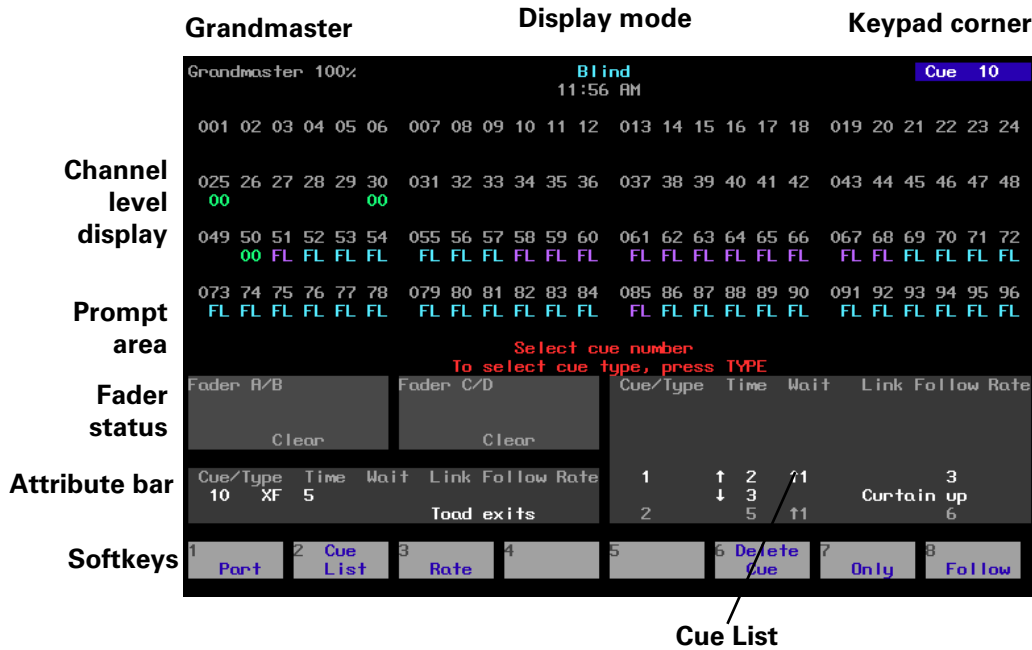

## Grandmaster

Current Grandmaster setting, Blackout alert and submaster page.

## Display mode

Current display mode and time

## Keypad corner

Indicates how the console will interpret the next number entered from the keypad. For example, if you press [Channel], the corner displays **Chan**, indicating that the console will read the next number as a channel number. If you enter a range, only the last number in the range will appear.

## Channel level display

Level of channels in the selected cue, group or submaster.

## Fader status

Indicates current status of both fader pairs. Shows cue running in fader, fade times, percentage of completion, and follow times.

## Attribute bar

Shows current settings for selected cue, group or submaster.

## Softkeys

Blind functions for [S1] through [S8].

## Cue List

Lists all cues along with their attributes. The next cue in the cue list is yellow. This can be changed from Stage mode, but not from Blind.

# Fader

The Fader display shows you only the levels on stage that have been set by the fader pairs.

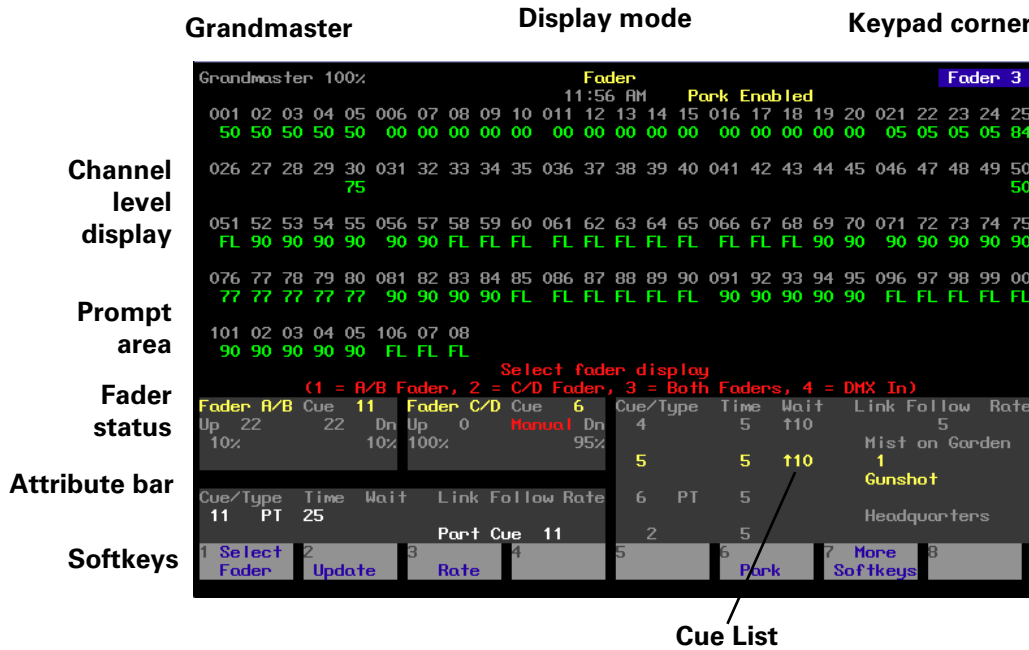

## Grandmaster

Current Grandmaster setting, Blackout alert and submaster page.

## Display mode

Current display mode and time

## Keypad corner

Indicates how the console will interpret the next number entered from the keypad. For example, if you press [Channel], the corner displays **Chan**, indicating that the console will read the next number as a channel number. If you enter a range, only the last number in the range will appear.

## Channel level display

Current level of all channels set by either or both faders.

## Prompt area

Information and prompts appear here.

## Fader status

Indicates current status of both fader pairs. Shows cue running in fader, fade times, percentage of completion, and follow times.

## Attribute bar

Shows current settings for selected cue, group or submaster.

## Softkeys

Fader functions for [S1] through [S8].

## Cue List

Lists all cues along with their attributes. The next cue in the cue list is yellow. This can be changed from Stage mode, but not from Blind.

# Flexichannel

If your system has the Flexichannel feature enabled, only channels used somewhere in the show appear on the display screens. These channels may be in cues, submasters or groups, or may be channels you have selected recently. By only displaying channels used in the show, you can reduce the amount of time you spend moving from page to page to find channels. All other screen elements are unchanged.

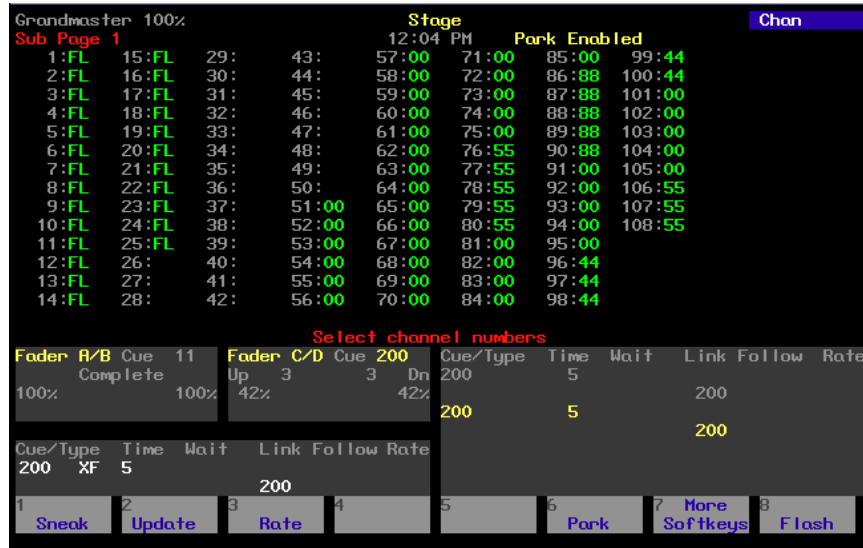

Working with Flexichannel active differs from working without Flexichannel in only one respect, selecting channels. See *Selecting channels in Flexichannel mode* on page 49 for more information.

*Note: In Tracksheet and Patch modes, channels are highlighted if they appear in the Flexichannel list, or are grayed out if they do not.*

See *Enable/disable Flexichannel* on page 22 for information on enabling Flexichannel.

## Updating Flexichannel

When channels that were used in a show are removed from the show, they remain on the channel list until it is updated. The Purge Flexi softkey on the System Settings display updates the list of used channels. The list is also updated when you load a show from diskette, or when you first turn Flexichannel on. Press [Setup] [1] [Enter] [S1], **Purge Flexi**, to update Flexichannel displays.

# Tracksheet

The Tracksheet display shows you how your channel levels are tracking through your cues.

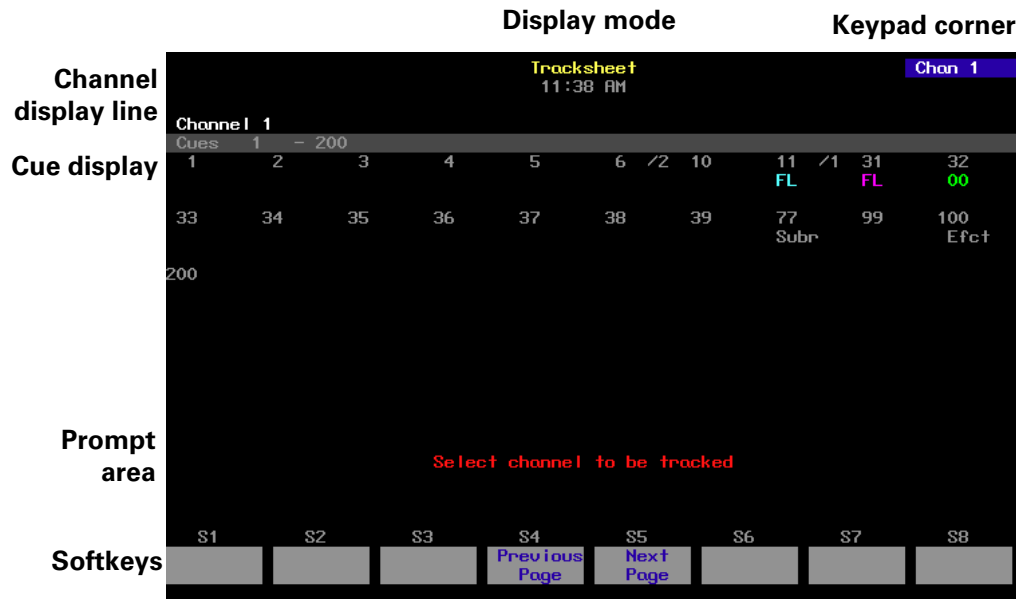

## Display mode

Current display mode and time.

## Keypad corner

This window indicates how the console will interpret the next number entered from the keypad. For example, if you press [Channel], the corner displays **Chan**, indicating that at the console will read the next number as a channel number.

## Channel display line

This line displays the current channel number being tracked. In Flexichannel mode, used channels are marked with an asterisk (\*).

## Cue display

The cue display lists the cues the channel tracks through and the level recorded in each.

## Prompt area

The operator prompt displays messages to guide you through Tracksheet functions.

## Softkeys

Tracksheet functions for [S1] through [S8].

# Patch

The Patch display allows you to create and modify your patch.

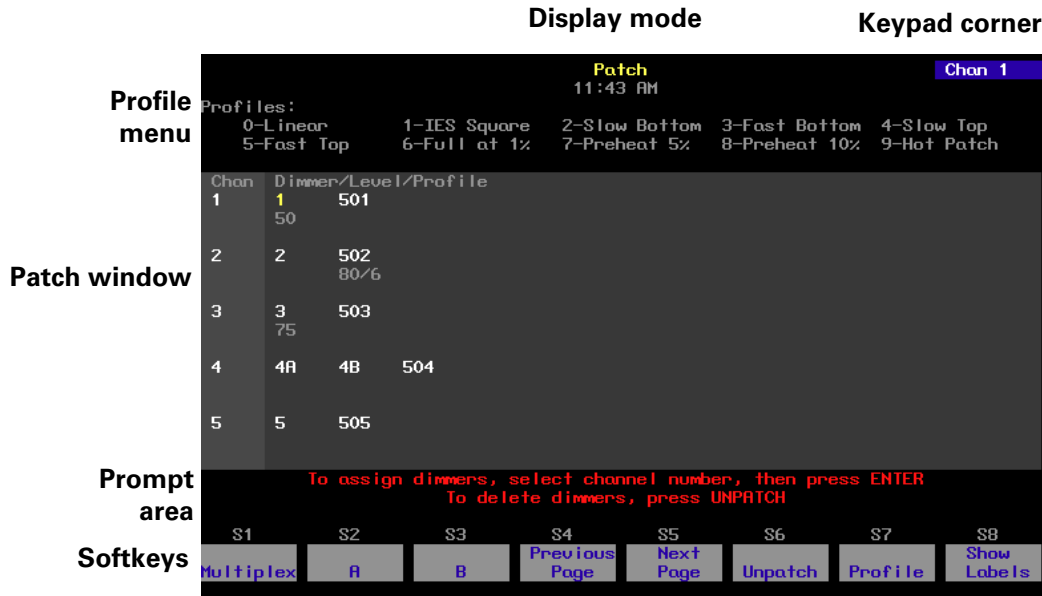

## Display mode

Current display mode and time.

## Keypad corner

This window indicates how the console will interpret the next number entered from the keypad. For example, if you press [Channel], the corner displays **Chan**, indicating that the console will read the next number as a channel number. If you enter a range, only the last number in the range will appear.

## Profile menu

Displays the profiles available to assign to dimmers.

## Patch window

Lists channels, dimmers patched to channels, and levels and/or profiles assigned to the dimmers. In Flexichannel mode, channels that are used are marked with an asterisk (\*).

## Prompt area

The operator prompt displays messages to guide you through Patch functions.

## Softkeys

Patch functions for [S1] through [S8].

# Park

The Park display lists parked dimmers on the top half of the screen, and parked channels on the lower half, along with their parked levels.

The screenshot shows the 'Park' display interface. At the top, it displays 'Park' and '12:59 PM'. The 'Keypad corner' shows 'Chan'. The 'Parked Dimmer window' lists dimmers 10, 15, 16, and 22, all at level 85. The 'Parked Channel window' lists channels 100 through 125, all at level FL. The 'Prompt area' contains the text: 'Select channel number(s), then press AT to park, or press RELEASE to unpark'. The 'Softkeys' row includes S1 through S8, with S4 labeled 'Previous Page' and S5 labeled 'Next Page'.

## **Display mode**

Current display mode and time.

## **Keypad corner**

This window indicates how the console will interpret the next number entered from the keypad. For example, if you press [Channel], the corner displays **Chan**, indicating that the console will read the next number as a channel number. If you enter a range, only the last number in the range will appear.

## **Parked Dimmer window**

Lists up to 36 parked dimmers and their levels.

## **Parked Channel window**

Lists up to 36 parked channels and their levels.

## **Operator prompt line**

The operator prompt displays messages to guide you through Park functions.

## **Softkeys**

Park functions for [S1] through [S8].



# chapter 3

## system settings

System settings allow you to customize Insight 2 for the number of dimmers and channels in your system, set system modes and screen formats, and choose default settings for a variety of console functions. The following illustration shows default settings.



This chapter includes the following sections:

- Setting number of dimmers
- Setting number of channels
- Setting default fade times
- Setting default Level
- Setting default fader clear times
- Setting default Sneak time
- Selecting Designer's Worksheet option
- Blackout key
- Selecting Flexichannel mode
- Master Type
- Set Channels/Submasters 1-to-1
- Selecting time format
- Record Lockout
- Bump keys
- Setting clock
- Naming show

## Setting number of dimmers

One of the first steps in configuring Insight 2 is to enter the number of dimmers in your system. Insight 2 defaults to 1,024 dimmers, the maximum number of dimmers the console can address.

Follow these steps to select up to 1,024 dimmers:

| <b>Keystrokes:</b>   | <b>Action:</b>   |
|--|--|
| 1. Press [Setup].  | Selects Setup display  |
| 2. Select [1], <b>System Settings</b> , and press [Enter].   | Selects System Settings menu                                       |
| 3. Select [1], <b>Number of Dimmers</b> , and press [Enter]. | Prompt reads:<br><b>Select number of dimmers, then press ENTER</b> |
| 4. Press [8][0][0] to enter the desired number of dimmers.   | Corner reads:<br><b>Dim 800</b>                                    |
| 5. Press [Enter].  | Number of dimmers is set to 800                                    |

*Note: If you increase the number of dimmers, the additional dimmers are initially patched to channel zero. From there, you can assign them to the channel of your choice.*

## Setting number of channels

Insight 2 allows you to control your dimmers with control channels. Insight 2 defaults to 108 channels, the maximum number of channels the console can address.

Follow these steps to select the number of channels:

| <b>Keystrokes:</b>  | <b>Action:</b>  |
|---|---|
| 1. Press [Setup].   | Selects Setup display   |
| 2. Select [1], <b>System Settings</b> , and press [Enter].    | Selects System Settings menu  |
| 3. Select [2], <b>Number of Channels</b> , and press [Enter]. | Prompt reads:<br><b>Select number of channels, then press ENTER</b> |
| 4. Press [4][5] to enter the desired number of channels.      | Corner reads:<br><b>Chan 45</b>                                     |
| 5. Press [Enter].   | Number of channels is set to 45                                     |

## Setting default fade times

Insight 2 allows you to assign default upfade and downfade times to cues or to control fade times manually. Default fade times are five seconds.

Fade times may be expressed in minutes and seconds, or as fractions of seconds (in decimal format). Fade times can be programmed from .1 second to 99:59 minutes. Acceptable time values include: .2 (.2 seconds), 00:12 (12 seconds), 5.5 (5.5 seconds), or 5:30 (five minutes, 30 seconds).

Follow these steps to assign your desired fade times:

| <b>Keystrokes:</b>   | <b>Action:</b>                                      |
|--|---|
| 1. Press [Setup].  | Selects Setup display                               |
| 2. Select [1], <b>System Settings</b> , and press [Enter].   | Selects System Settings menu                        |
| 3. Select [3], <b>Default Fade Time</b> , and press [Enter]. | Prompt reads:<br><b>Enter default up fadetime</b>   |
| 4. Press [6] to enter a six second upfade time.              | Corner reads:<br><b>UpTime 6</b>                    |
| 5. Press [Enter].  | Prompt reads:<br><b>Enter default down fadetime</b> |
| 6. Press [3] to enter a three second downfade time.          | Corner reads:<br><b>DnTime 3</b>                    |
| 7. Press [Enter].  | Fade times are reset                                |

*Note: If the upfade and downfade times are the same, both will change when you change the upfade time.*

## Setting default Level

Insight 2 allows you to assign a value to the [Level] key. The default value is 100 percent. You may assign [Level] any value between zero and 100.

Follow these steps to assign a value to [Level]:

| <b>Keystrokes:</b>   | <b>Action:</b>   |
|--|--|
| 1. Press [Setup].  | Selects Setup display  |
| 2. Select [1], <b>System Settings</b> , and press [Enter].   | Selects System Settings menu   |
| 3. Select [4], <b>Default Level</b> , and press [Enter].   | Prompt reads:<br><b>Enter default level<br/>(Press FULL button for 100%)</b> |
| 4. Use the keypad to enter the two-digit value (00-99) you wish to assign to [Level], or press [Full]. | New default for [Level] is set   |

*Note: To enter a level between one and nine percent, you must press zero then the number. For example, to set the default level to five percent, press [0][5] in step 4.*

## Setting default fader clear time

Pressing the [Clear] key above one of the fader pairs clears the cue from the fader, fading all channels in that fader to zero. The default fader clear time determines the fade time for both [Clear] keys. Channels black out immediately when clear time is zero.

Fade times may be expressed in minutes and seconds, or as fractions of seconds (in decimal format). Fade times can be programmed from .1 second to 99:59 minutes. Acceptable time values include: .2 (.2 seconds), 00:12 (12 seconds), 5.5 (5.5 seconds), or 5:30 (five minutes, 30 seconds).

Follow these steps to set a new default fade time:

| <b>Keystrokes:</b>  | <b>Action:</b>   |
|---|--|
| 1. Press [Setup].   | Selects Setup display                                  |
| 2. Select [1], <b>System Settings</b> , and press [Enter].          | Selects System Settings menu                           |
| 3. Select [5], <b>Default Fader Clear Time</b> , and press [Enter]. | Prompt reads:<br><b>Enter default fader clear time</b> |
| 4. Press [9] to enter the time value you wish to assign.            | Corner reads:<br><b>Time 9</b>                         |
| 5. Press [Enter].   | New default time is set to nine seconds                |

## Setting default Sneak time

**Sneak** allows you to fade or restore channel levels on stage in a specified time.

The console allows you to assign a default Sneak time. For more information about the Sneak function, see page 51. Default time is five seconds for a Sneak.

Follow these steps to set a new Sneak time:

| <b>Keystrokes:</b>  | <b>Action:</b>                                   |
|---|--|
| 1. Press [Setup].   | Selects Setup display                            |
| 2. Select [1], <b>System Settings</b> , and press [Enter].                | Selects System Settings menu                     |
| 3. Select [6], <b>Default Sneak Time</b> , and press [Enter].             | Prompt reads:<br><b>Enter default sneak time</b> |
| 4. Enter the time you wish to assign as the Sneak time and press [Enter]. | Sets the new default Sneak time                  |

# Setting Designer's Worksheet options

The Designer's Worksheet options display allows you to choose the template you wish to use and enable the sliders on either the console or the digitizer.

*Note: The Grandmaster, fader and submaster sliders may only be enabled on the console or the digitizer, not both.*

For more information about the Designer's Worksheet, see page 207.

Follow these steps to set Designer's Worksheet options:

- | <b>Keystrokes:</b>  | <b>Action:</b>  |
|---|---|
| 1. Press [Setup].   | Selects Setup display   |
| 2. Select [1], <b>System Settings</b> , and press [Enter].            | Selects System Settings menu  |
| 3. Select [7], <b>Designer's Worksheet Setup</b> , and press [Enter]. | Prompt reads:<br><b>Select Designer's Worksheet setup, then press ENTER</b><br>The following display appears: |

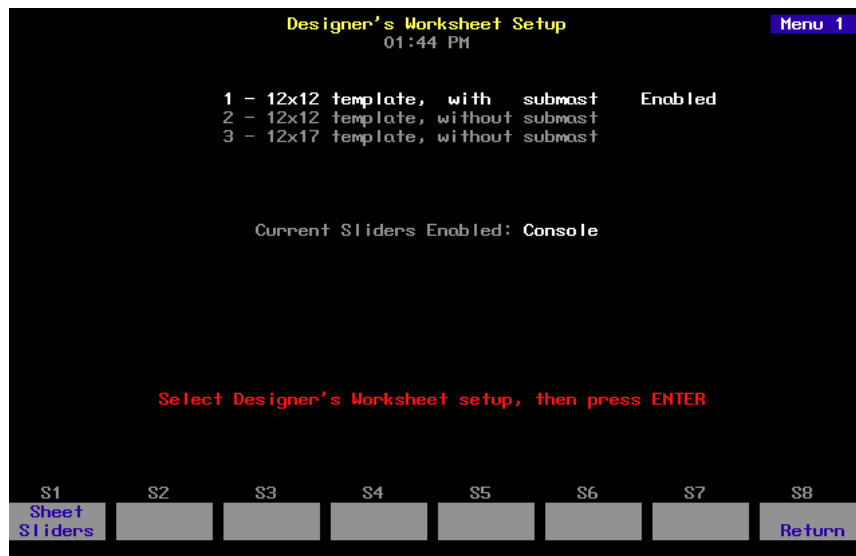

- |  |   |
|--|---|
| 4. Press [2] to select a 12x12 template without submasters.  | Corner reads: <b>Menu 2</b>   |
| 5. Press [S1], <b>Sheet Sliders</b> , to disable the slider controls on the console, or [S1], <b>Console Sliders</b> , to disable the slider controls on the digitizer (if any). | Display indicates which option is selected; softkey indicates which option is <u>not</u> selected |
| 6. Press [Enter].  | Designer's Worksheet option is set  |

## ***Enable/disable Blackout key***

Insight 2's [Blackout] key may be enabled or disabled. Insight 2 defaults to enabled.

Follow these steps to enable or disable [Blackout]:

| <b>Keystrokes:</b>   | <b>Action:</b>  |
|--|---|
| 1. Press [Setup].  | Selects Setup display   |
| 2. Select [1], <b>System Settings</b> , and press [Enter]. | Selects System Settings menu  |
| 3. Select [8], <b>Blackout Key</b> , and press [Enter].    | Prompt reads:<br><b>Enable/disable blackout key</b><br><b>(1 = Enable, 0 = Disable)</b> |
| 4. Press [1] or [0].                                       | Corner reads:<br><b>Black 1</b><br>Or...<br><b>Black 0</b>                              |
| 5. Press [Enter].  | [Blackout] is enabled or disabled   |

## ***Enable/disable Flexichannel***

Insight 2's Command display can be set to operate in full display mode or in Flexichannel mode. In full display mode, channel displays show all channels and their current status. In Flexichannel mode, only channels with a recorded level appear. Insight 2 defaults to full channel display.

Follow these steps to enable or disable Flexichannel:

| <b>Keystrokes:</b>   | <b>Action:</b>  |
|--|---|
| 1. Press [Setup].  | Selects Setup display   |
| 2. Select [1], <b>System Settings</b> , and press [Enter]. | Selects System Settings menu  |
| 3. Select [9], <b>Flexichannel</b> , and press [Enter].    | Prompt reads:<br><b>Enable/disable flexichannel<br/>(1 = Enable, 0 = Disable)</b> |
| 4. Press [1] or [0].                                       | Corner reads:<br><b>Flexi 1</b><br>Or...<br><b>Flexi 0</b>                        |
| 5. Press [Enter].  | Flexichannel mode is enabled or disabled  |

## ***Updating Flexichannel***

When channels that were used in a show are removed from the show, they remain on the channel list until it is updated. The Purge Flexi softkey on the System Settings display updates the list of used channels. The list is also updated when you load a show from diskette, or when you first turn Flexichannel on. Press [Setup] [1] [Enter] [S1], **Purge Flexi**, to update Flexichannel displays.

## Set Master type

You may set the Master slider (labeled Grandmaster on older Expression 2 line consoles) to one of three control options.

- **Disabled**  
Master slider does nothing.
- **Grandmaster**  
Master slider controls all levels on stage except parked channels and independent channels.
- **Sub Grandmaster**  
Master slider controls all levels on stage set by submasters.

To configure your Master slider, follow these steps:

| Keystrokes:                                     | Action:   |
|---|---|
| 1. Press [Setup].                               | Displays Setup menu   |
| 2. Press [1], <b>System Settings</b> , [Enter]. | Displays System Settings menu   |
| 3. Press [1][0], <b>Master Type</b> , [Enter].  | Prompt reads:<br><b>Select master type and press ENTER (0 = Disabled, 1 = Grandmaster, 2 = Sub Grandmaster)</b> |
| 4. Press [1] [Enter].                           | Master is set as Grandmaster  |

## Set Channels/Submasters 1-to-1

Set Channels/Submasters 1-to-1 sets your console's channels to a one-to-one match with your submasters. Thus, channel 1 is patched to submaster 1, channel 2 to submaster 2, and so on. Channel levels are set to Full and up/dwell/down times are set to 1/Manual/1.

To reset your channels and submasters, follow these steps:

| Keystrokes:   | Action:  |
|---|--|
| 1. Press [Setup].   | Displays Setup menu  |
| 2. Press [1], <b>System Settings</b> , [Enter].                   | Displays System Settings menu  |
| 3. Press [1][1], <b>Set Channels/Submasters 1-to-1</b> , [Enter]. | Prompt reads:<br><b>Select page to default, then press ENTER (1 = Page 1, 2 = Page 2, 0 = All pages)</b> |
| 4. Press [Enter].   | Channels are assigned to submasters.<br>The display returns to Setup menu                                |

## Setting time format

Insight 2 consoles allow you to display time in either 12 or 24 hour format.

Follow these steps to choose your preference:

| <b>Keystrokes:</b>   | <b>Action:</b>   |
|--|--|
| 1. Press [Setup].  | Selects Setup display  |
| 2. Select [1], <b>System Settings</b> , and press [Enter].     | Selects System Settings menu   |
| 3. Select [1][2], <b>12/24 hour clock</b> , and press [Enter]. | Prompt reads:<br><b>Enter 12 or 24 hour clock<br/>(0 = 12 hour, 1 = 24 hour)</b> |
| 4. Enter [0] or [1] and press [Enter].                         | Sets the clock mode  |

## Record Lockout

You may set the console to disable the Record function. This protects a finished show from inadvertent changes.

To disable the Record function in your system, follow these steps:

| <b>Keystrokes:</b>   | <b>Action:</b>  |
|--|---|
| 1. Press [Setup].  | Selects Setup display   |
| 2. Select [1], <b>System Settings</b> , and press [Enter]. | Selects System Settings menu. Menu indicates current status of Record Lockout   |
| 3. Select [1][3], <b>Record Lockout</b> .                  | Prompt reads:<br><b>Enable/Disable record lockout<br/>(1 = Enable, 0 = Disable)</b>   |
| 4. Press [1] [Enter] to lock out the record function.      | Record is locked out. If you attempt to record anything, the prompt reads:<br><b>Record is locked out<br/>(Press CLEAR to continue)</b> |

*Note: As always, the best way to safeguard your show is to make backups. See Chapter 17, *Diskette functions*, for instructions on backing up a show to diskette.*

## ***Enable/disable Bump keys***

Insight 2's submaster bump buttons may be enabled or disabled. Insight 2 defaults to enabled.

Follow these steps to enable or disable all submaster bump buttons:

| <b>Keystrokes:</b>   | <b>Action:</b>   |
|--|--|
| 1. Press [Setup].  | Selects Setup display  |
| 2. Select [1], <b>System Settings</b> , and press [Enter]. | Selects System Settings menu   |
| 3. Select [1][4], <b>Bump keys</b> , and press [Enter].    | Prompt reads:<br><b>Enable/disable bump keys</b><br><b>(1 = Enable, 0 = Disable)</b> |
| 4. Press [1] or [0].                                       | Corner reads:<br><b>BpStat 1</b><br>Or...<br><b>BpStat 0</b>                         |
| 5. Press [Enter].  | Submaster bump buttons are enabled or disabled                                       |

## Setting clock

To set the current time and date in your system, follow these steps:

| Keystrokes:                       | Action:                       |
|-----------------------------------|-------------------------------|
| 1. Press [Setup].                 | Selects Setup display         |
| 2. Press [S2], <b>Set Clock</b> . | The following screen appears: |

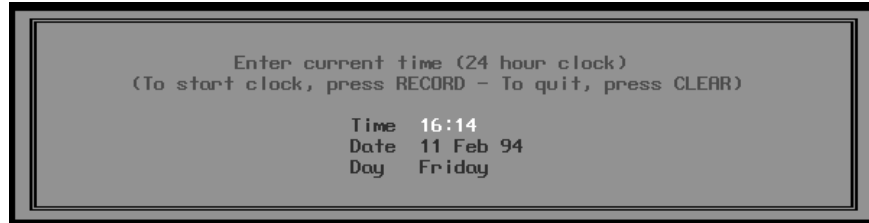

|   |                                       |
|---|---------------------------------------|
| 3. Enter the current time in hours and minutes. Time entry format corresponds to your clock mode setting in System Settings. (In 24-hour format, 930 = 9:30 AM, 1625 = 4:25 PM) (In 12-hour format, use [+] to select AM or PM. | New time appears on screen            |
| 4. Press [Enter].   | Time is set; Date is highlighted      |
| 5. Enter the day of the month (1-31) and press [Enter].   | New date is set; Month is highlighted |
| 6. Enter the month (1-12) and press [Enter]   | New month is set; Year is highlighted |
| 7. Enter the year (00-99) and press [Enter]   | New year is set; Day is highlighted   |
| 8. Enter the day of the week (1-7) and press [Enter]  | New day is set; Time is highlighted   |
| 9. Press [Record] to reset Real Time Clock with the new settings.   | Returns to Setup display              |

*Note: You may use [+] and [-] to scroll through the options in any of the fields on this screen.*

## ***Naming show***

You can use an alphanumeric keyboard to name the show currently loaded in the console. The names you give shows can consist of letters, numbers or the symbols: **#, %, &, \*, (, ), +, ', -, [, ], /** as well as the comma and period. You may enter the name using overwrite or insert mode. In overwrite, you type over any previously entered characters; in insert mode, each new character pushes the previously entered characters one space to the right. Press [Insert] on the keyboard to switch between insert and overwrite mode. See page 282 for information about installing an alphanumeric keyboard.

To name the show in your system, follow these steps:

| <b>Keystrokes:</b>  | <b>Action:</b>  |
|---|---|
| 1. Press [Setup].   | Selects Setup display   |
| 2. Press [S1], <b>Show Name</b> .   | Prompt reads:<br><b>Type show label</b><br><b>(F6 = clear to end)</b> |
| 3. Enter the name you want to give the show on the alphanumeric keyboard. The show name can have up to 20 characters. | New name appears in corner of screen                                  |
| 4. Press [Enter] on the alphanumeric keyboard to record the name, or press [Esc] to quit and return to Setup display. | Show is named   |



# chapter 4

## patch

Before you begin creating cues for a show you should first create your patch. The patch assigns individual dimmers to control channel numbers. The Insight 2 Patch display allows you to assign up to 1,024 DMX512 dimmers to up to the maximum number of control channels your console can address.

You can use Insight 2's default one-to-one patch, or you may create a custom patch. In addition, Insight 2's proportional patching capability allows you to set dimmer output levels and assign one of ten output profiles to dimmers.

If you are patching dimmers in a Strand CD80 dimmer rack, see page 41 for special instructions.

Before patching, be certain that the system settings reflect the total number of available dimmers and channels. See *Chapter 3, Entering system settings*, on page 16 for information on setting the number of dimmers and channels.

This chapter includes the following sections:

- Selecting one-to-one patch
- Creating custom patch
- Proportional patching
- Labeling dimmers
- Assigning a profile to a dimmer
- Capturing channels in Patch
- Dimmer check
- About Dimmer
- Multiplexed dimmers
- Patching to a Strand CD80 dimmer rack

## Selecting one-to-one patch

The one-to-one patch assigns dimmer 1 to channel 1, dimmer 2 to channel 2 and so on. If there are more dimmers than channels, the one-to-one patch assigns the first extra dimmer to channel 1, the second extra dimmer to channel 2, and so on.

Follow these steps to select Insight 2's default one-to-one patch:

| <b>Keystrokes:</b>  | <b>Action:</b>   |
|---|--|
| 1. Press [Setup] to display the Setup menu.   | Selects Setup display  |
| 2. Press [4], <b>Clear Functions</b> [Enter].   | Prompt reads:<br><b>Select function number, then press ENTER</b>                     |
| 3. Press [9], <b>Reset Patch 1 to 1</b> [Enter].  | Prompt reads:<br><b>To reset patch, press ENTER</b><br><b>To cancel, press CLEAR</b> |
| 4. Press [Enter] to confirm your selection of one-to-one default patch, or press [Clear] to cancel the operation. | Sets patch to default one-to-one patch   |

## Creating custom patch

Insight 2's custom patching capability allows you to create virtually any dimmer to channel configuration you like. (Groups of dimmers may be assigned to single channels, but only one channel may be patched to a dimmer.)

*Hint: If you use the same patch for several shows, create the patch, and record it on a disk before you record any cues. Label the disk **Standard patch**. When you start your next show, read the Standard patch show into the console, then begin writing cues to avoid reentering the patch.*

## ***Patching dimmers to channels***

Follow these steps to patch a dimmer(s) to a control channel:

| <b>Keystrokes:</b>  | <b>Action:</b>  |
|---|---|
| 1. Press [Patch].   | Selects Patch display   |
| 2. Press [Dim]. (If the LED in the [Dim] key is lit, you may omit this step.)   |   |
| 3. Use the keypad to enter the numbers of the dimmers you want to patch. Use [And] and [Thru] if you want to select more than one dimmer. | Prompt reads:<br><b>Select dimmer numbers, then press ENTER to assign to a channel, or press AT to assign a level, or press PROFILE to assign a profile</b> |
| 4. Press [Enter].   | Prompt reads:<br><b>To assign dimmers, select channel number, then press ENTER<br/>To delete dimmers, press UNPATCH</b>                                     |
| 5. Enter the channel number to which you want to patch the selected dimmers and press [Enter].  | Dimmer(s) are patched to the channel  |
| 6. Repeat steps 2 through 4 to patch additional dimmers.  |   |

## Proportional patching

Insight 2 allows you to proportionally inhibit the output of individual dimmer levels from the Patch display. Dimmers output at 100 percent unless you patch them at a lower level.

Dimmer intensity levels set in Patch function at full level on all other screens. For example, if you enter a level of 60 for a dimmer on the patch screen, when you set that channel to full in a cue or submaster, the dimmer will output at 60 percent.

Follow these steps to assign a proportional dimmer output level:

### Keystrokes:

1. Press [Patch].
2. If the [Dim] LED is unlit, press [Dim] to indicate that the next number entered will be a dimmer.
3. Use the keypad to enter the desired dimmer number(s). Use [And] and [Thru] if you want to select more than one dimmer.
4. Press [At]
5. Use the keypad to enter the desired maximum output level for the dimmer(s). Full is displayed until a new level is entered. Enter a zero before single-digit levels (i.e., **08**).

### Action:

Selects Patch display

Prompt reads:

**Select dimmer numbers, then press ENTER to assign to a channel, or press AT to assign a level, or press PROFILE to assign a profile**

Prompt reads:

**Select dimmer numbers, then press ENTER to assign to a channel, or press AT to assign a level, or press PROFILE to assign a profile**

Prompt reads:

**Select dimmer level**

Dimmer's proportional level is set

*Note: If the dimmer's level is highlighted, white on red, you may use [+] and [-] to adjust the level. Press [Enter] to record the edited level.*

## ***Unpatching individual dimmers***

Channel zero is not an actual control channel. It functions as a holding area in which you may store dimmers not included in your patch. Before you begin creating a custom patch, you may find it helpful to assign all dimmers to channel zero. Then, when you begin patching, you can select dimmers from channel zero and patch them to channels as you like.

Dimmers assigned to channel zero are listed at the end of channel list under "--." These dimmers are not assigned to any channel, but remain on the patch screen.

Follow these steps to assign dimmers to channel zero in By Dimmer mode:

### **Keystrokes:**

1. Press [Patch].
2. If the [Dim] LED is unlit, press [Dim] to indicate that the next number entered will be a dimmer.
3. Use the keypad to enter the desired dimmer number(s) Use [And] and [Thru] if you want to select more than one dimmer.
4. Press [S6], **Unpatch.**

### **Action:**

Selects Patch display

Prompt reads:

**Select dimmer numbers, then press ENTER to assign to a channel, or press AT to assign a level, or press PROFILE to assign a profile**

Prompt reads:

**Select dimmer numbers, then press ENTER to assign to a channel, or press AT to assign a level, or press PROFILE to assign a profile**

Selected dimmers are unpatched and assigned to channel zero (--)

## Labeling dimmers

Insight 2 allows you to assign alphanumeric labels to your dimmers. Dimmer labels may be up to five characters long and may consist of any combination of characters, including letters, numbers and symbols.

In the Patch display, Insight 2 allows you to view labels you have assigned to dimmers. Press [S8], **Show/Hide Labels**, to reveal or hide the labels. Hiding labels provides space to show additional dimmers.

This example demonstrates how to assign a label to a dimmer:

| <b>Keystrokes:</b>                                | <b>Action:</b>   |
|---|--|
| 1. Press [Patch].                                 | Selects Patch display  |
| 2. Press [5] [Label].                             | Selects dimmer 5 to label<br>Prompt reads:<br><b>Type dimmer label</b><br><b>(F6 = clear to end,</b><br><b>F7 = last dimmer label,</b><br><b>F8 = next dimmer label)</b> |
| 3. Use the alphanumeric keyboard to type "House." | Corner reads: <b>Label House</b>   |
| 4. Press [Enter] on the Insight 2 keypad.         | Dimmer 5 is labeled "House"  |

*Note: In step 4, if you wish to label another dimmer, press [F7] or [F8] instead of [Enter]. Insight 2 records the current dimmer's label, and brings up the previous or next dimmer to be labeled.*

# Assigning a profile to a dimmer

Dimmer profiles allow you to select one of ten output curves (profiles) and assign it to a dimmer. These profiles allow you to compensate for non-linear light outputs from certain types of fixtures or incorporate a preferred response in a fade. The ten curves are listed below.

If you do not select a profile, all dimmers use profile zero; a linear fade.

Follow these instructions to assign a profile to a dimmer:

| <b>Keystrokes:</b>   | <b>Action:</b>  |
|--|---|
| 1. Press [Patch].  | Selects Patch display   |
| 2. If the [Dim] LED is unlit, press [Dim] to indicate that the next number entered will be a dimmer.   | Prompt reads:<br><b>Select dimmer numbers, then press ENTER to assign to a channel, or press AT to assign a level, or press PROFILE to assign a profile</b> |
| 3. Use the keypad to enter the desired dimmer number(s) Use [And] and [Thru] if you want to select more than one dimmer.   | Prompt reads:<br><b>Select dimmer numbers, then press ENTER to assign to a channel, or press AT to assign a level, or press PROFILE to assign a profile</b> |
| 4. Press [S7], <b>Profile</b> , then use the keypad to enter the number of the desired profile. Profile numbers are listed on menu at the top of the Patch screen. | Prompt reads:<br><b>Select dimmer profile number</b>  |

*Note: To reset profile to a linear fade, assign profile zero to the dimmer.*

## Dimmer profiles

- 0 - Linear
- 1 - IES square
- 2 - Slow bottom
- 3 - Fast bottom
- 4 - Slow top
- 5 - Fast top
- 6 - Full at 1% \*
- 7 - Preheat 5% †‡
- 8 - Preheat 10% †‡
- 9 - Hot patch †‡

\* Dimmer intensity jumps from 0% to 100% at 1% output.

† Dimmer at 5% or 10% whenever console power is on. Dimmer intensity increases when output exceeds 5% or 10%.

‡ Dimmer at full whenever console power is on.

‡ Affected by [Blackout] but not by Grandmaster.

## ***Capturing channels in Patch***

Insight 2 lets you select and capture channels without returning to Stage mode. This allows you to bring channels up on stage to view the proportional settings of dimmers assigned to a channel while you set them.

To select channels from the patch screen, follow these steps:

### **Keystrokes:**

1. Press [Patch].
2. Press [Channel].
3. Use the keypad to enter the desired channel number(s) Use [And] and [Thru] if you want to select more than one channel.
4. Press [Full] to set channel level at 100 percent, [Level] to set channel at the default level, or press [At] and enter a level setting.
5. Press [Rel] to release channel(s).

### **Action:**

Selects Patch display

Prompt reads:

**Select channel numbers**

Prompt reads:

**Select channel numbers**

Selected channels are set at the indicated level

## Dimmer check

A dimmer check allows you to raise your dimmers to a specified level on stage, one at a time. Insight 2 allows you to select the starting dimmer and set it at a level. Once you select the dimmer, use [+] to check each consecutive dimmer.

Follow these steps to run a dimmer check:

| <b>Keystrokes:</b>  | <b>Actions:</b>   |
|---|---|
| 1. Press [Dim].   | Prompt reads:<br><b>Enter dimmer number(s), then press AT to select level</b>   |
| 2. Press [1] to start dimmer check with dimmer 1.   | Keypad corner reads:<br><b>Dim 1</b>  |
| 3. Press [At].  | Prompt reads:<br><b>Select dimmer level (Press FULL button for 100%)</b>  |
| 4. Press [7][5] to set the dimmer's level at 75 percent. You may also press [Full] or [Level] to set the dimmer at 100 percent or at the [Level] setting. | Prompt reads:<br><b>To unpatch dimmer for dimmer check, press ENTER</b><br><b>To park or unpatch dimmer(s), press PARK</b>  |
| 5. Press [Enter].   | Dimmer 1 is set at 75 percent<br>Dimmer Check window appears<br>Prompt reads:<br><b>Press [+] or [-] to step through dimmers. Press [Clear] to cancel dimmer check.</b> |
| 6. Press [+] to select dimmer 2. Repeat as necessary. Press [Clear] to end dimmer check.  | Dimmer 1 returns to zero, dimmer 2 is set at 75 percent   |

*Note: If a dimmer is parked, the Dimmer Check window displays the level at which it is parked. The Dimmer Check does not change its level on stage.*

*Note: To check a multiplexed B dimmer, enter the number, selecting the A dimmer, then press [+] to select the B dimmer.*

# About

[About] provides you with information about dimmers. The following pages describe the use of About Dimmer and the information available in the About Dimmer window.

*Note: See page 53 for information on using About Channel.*

## About Dimmer

About Dimmer provides attribute and status information for a selected dimmer. To display the About Dimmer window, follow these steps:

| Keystrokes:                | Action:   |
|----------------------------|---|
| 1. Press [About] [Dimmer]. | Prompt reads:<br><b>About: Select dimmer number, then press ENTER</b> |
| 2. Press [6].              | Keypad corner reads:<br><b>Dim 6</b>                                  |
| 3. Press [Enter].          | About Dimmer window is displayed                                      |



- **Label:** The dimmer's label.
- **Channel:** The channel to which the dimmer is assigned.
- **Proportion:** The dimmer's assigned proportional level.
- **Profile:** The dimmer's assigned profile.
- **Console dimmer level:** The dimmer output level the Insight 2 console is sending to the dimmer.
- **Parked:** Whether or not the dimmer is parked.

*Note: Press [Clear] to remove the About window.*

## About Dimmer with ETCLink

If your console uses ETCLink to monitor dimmers in an ETC Sensor dimming system, the About Dimmer window displays additional dimmer monitoring information. The following expanded About Dimmer window appears if dimmer monitoring is enabled.



- **Label:** The dimmer's label.
- **Channel:** The channel to which the dimmer is assigned.
- **Proportion:** The dimmer's assigned proportional level.
- **Profile:** The dimmer's assigned profile.
- **Console dimmer level:** The dimmer output level the Insight 2 console is sending to the dimmer.
- **Parked:** Whether or not the dimmer is parked.
- **Rack/Slot number:** The rack and slot in which this dimmer is located.
- **Rack dimmer level:** The actual output level at which the dimmer is set.
- **Dimmer level source:** The source of the control signal which set the dimmer's level. Possible sources include:
  - **DMX A**
  - **DMX B**
  - **Rack #**

The following information is available on Sensor Advanced Features dimming systems.

- **Recorded lamp load:** The load at which the selected dimmer was recorded.
- **Load at full:** The estimated load on the dimmer when the level is at Full.
- **Actual load:** The actual load currently on the dimmer.
- **Boost:** The dimmer's boost level, if any.
- **Dimmer error:** Current dimmer errors, if any.

# Multiplexed dimmers

ETC's Multiplex dimming technology can increase the capacity of your dimming system. The ETC Multiplexer converts the output of a single ETC Sensor or L86 dimmer into two separate signals. Both signals then provide discrete levels for two ETC Source Four lighting fixtures.

*Warning: The DMX512 port that serves the dimmer must be in multiplex mode. Setting the port to multiplex mode erases your current patch. Set the port mode BEFORE you create your patch. To set the port's mode, see Setting Multiplex mode on page 280.*

Before you create your patch, you must identify any dimmers whose signals are multiplexed. Insight 2 indicates the split by adding an **A** or **B** to the dimmer number.

Follow these steps to multiplex a dimmer:

| <b>Keystrokes:</b>   | <b>Action:</b>  |
|--|---|
| 1. Press [Patch].  | Selects Patch display   |
| 2. If the [Dim] LED is unlit, press [Dim] to indicate that the next number entered will be a dimmer.                     | Prompt reads:<br><b>Select dimmer numbers, then press ENTER to assign to a channel, or press AT to assign a level, or press PROFILE to assign a profile</b> |
| 3. Use the keypad to enter the desired dimmer number(s) Use [And] and [Thru] if you want to select more than one dimmer. | Prompt reads:<br><b>Select dimmer numbers, then press ENTER to assign to a channel, or press AT to assign a level, or press PROFILE to assign a profile</b> |
| 4. Press [S1], <b>Multiplex</b> .  | Selected dimmers are identified as Multiplexed  |

*Note: Use [S2], **A**, and [S3], **B**, along with the numeric keypad, to enter dimmer numbers as you create your patch. If you select a multiplexed dimmer without specifying **A** or **B**, the system defaults to **A**.*

## Patching to a Strand CD80 dimmer rack

Strand CD80 dimmer racks have 48 dimmer slots. Each dimmer slot holds either two 2.4kW dimmers or one 6kW or 12kW dimmer. The console requires that you include all 96 possible dimmer numbers per rack in the patch.

Refer to the charts below to determine dimmer numbers for each slot on each rack. When patching 6kW or 12kW dimmers, enter the slot's odd dimmer number under the desired channel number. Enter the slot's even dimmer number under channel zero.

For example, to patch a 6kW dimmer into the last dimmer slot on the first rack, enter dimmer 95 in the desired channel number and dimmer 96 in channel zero.

|    |    |    |    |    |    |     |     |     |     |     |     |
|----|----|----|----|----|----|-----|-----|-----|-----|-----|-----|
| 1  | 3  | 5  | 7  | 9  | 11 | 97  | 99  | 101 | 103 | 105 | 107 |
| 2  | 4  | 6  | 8  | 10 | 12 | 98  | 100 | 102 | 104 | 106 | 108 |
| 13 | 15 | 17 | 19 | 21 | 23 | 109 | 111 | 113 | 115 | 117 | 119 |
| 14 | 16 | 18 | 20 | 22 | 24 | 110 | 112 | 114 | 116 | 118 | 120 |
| 25 | 27 | 29 | 31 | 33 | 35 | 121 | 123 | 125 | 127 | 129 | 131 |
| 26 | 28 | 30 | 32 | 34 | 36 | 122 | 124 | 126 | 128 | 130 | 132 |
| 37 | 39 | 41 | 43 | 45 | 47 | 133 | 135 | 137 | 139 | 141 | 143 |
| 38 | 40 | 42 | 44 | 46 | 48 | 134 | 136 | 138 | 140 | 142 | 144 |
| 49 | 51 | 53 | 55 | 57 | 59 | 145 | 147 | 149 | 151 | 153 | 155 |
| 50 | 52 | 54 | 56 | 58 | 60 | 146 | 148 | 150 | 152 | 154 | 156 |
| 61 | 63 | 65 | 67 | 69 | 71 | 157 | 159 | 161 | 163 | 165 | 167 |
| 62 | 64 | 66 | 68 | 70 | 72 | 158 | 160 | 162 | 164 | 166 | 168 |
| 73 | 75 | 77 | 79 | 81 | 83 | 169 | 171 | 173 | 175 | 177 | 179 |
| 74 | 76 | 78 | 80 | 82 | 84 | 170 | 172 | 174 | 176 | 178 | 180 |
| 85 | 87 | 89 | 91 | 93 | 95 | 181 | 183 | 185 | 187 | 189 | 191 |
| 86 | 88 | 90 | 92 | 94 | 96 | 182 | 184 | 186 | 188 | 190 | 192 |



# *chapter 5*

## *setting channel levels*

Setting channel levels is the first step in recording cues, submasters and groups. Setting channel levels in Stage mode brings light levels up on stage. Setting channel levels in Blind mode does not affect stage lights.

This chapter includes the following sections:

- Channel modes
- Channel attributes
- Selecting channels
- Setting channel levels
- Channel check
- About Channel

## ***Channel modes***

Channels may be in any of the following modes. Each responds differently to commands.

### ***Captured channels***

Captured channels are channels that you have selected and are live on stage. They remain live until you press [Rel] to release them. **Captured channels override all other channel settings.** For example, if a channel is in a fader at 100 percent and you capture it and set it to 50 percent, Insight 2 sets the captured channel at 50 percent. Press [Rel] twice to release captured channels.

### ***Selected channels***

Selected channels are channels over which you have immediate keypad control. You can modify selected channels with [Full], [At], [+], [-], or the fader wheel. Selected channels are displayed in yellow, and their levels are red on white. You can select channels in all display modes.

*Selected, captured* channels are *live* channels that are under immediate keypad control. Channels can be *selected and captured* only in Stage modes. You can select channels in Blind, but they won't be captured since Blind mode is not live. Press [Rel] once to release selected channels.

### ***Recorded channels***

Recorded channels are channel levels that have been recorded in a cue, group or submaster. In Stage mode, recorded levels are displayed in green or magenta. Recorded channels may be either moving or tracked in Blind mode (see below). Channel levels controlled by effects are displayed in white. Channel levels controlled by submasters other than effect submasters are displayed in yellow.

### ***Moving channels***

Moving channels are channel levels that change from one cue to the next. In Stage mode, all moving channels are displayed in green. In Blind and Tracksheet, moving channels are displayed in green if they are moving down or blue if they are moving up.

### ***Tracked channels***

A tracked channel is a channel whose level is unchanged from the preceding cue. Tracked channels are displayed in magenta.

# Channel Attributes display

The Channel Attributes display allows you to assign attributes to specific channels, including:

- **Independent**  
Allows a channel to be unaffected by Grandmaster, Flash, Release, Solo, and Blackout. (Release requires an extra keypress.)
- **Flip**  
Allows a channel's output to be reversed. A flipped channel outputs at full when set to zero and at zero when set to full.
- **Label**  
Allows you to assign labels to channels.

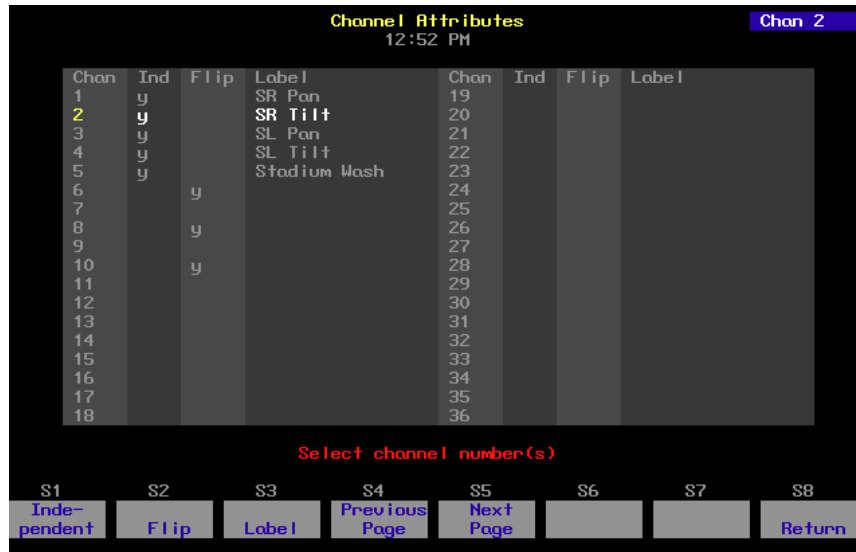

To go to the Channel Attributes display, follow these steps:

### Keystrokes:

1. Press [Setup].
2. Press [1][1] [Enter].

### Action:

1. Selects Setup menu
2. Selects Channel Attribute display

## ***Independent channels***

An independent channel is not affected by the Grandmaster, Blackout, Solo, or Flash. Otherwise, independent channels function normally. Use [S1], **Independent**, to make a channel independent. Press [Rel] three times to release all independent channels.

Channels that control movement of moving lights or color scrollers will often be set as Independent. This assures that in the case of a blackout or change in the Grandmaster setting, the position of the moving light or color scroller will not change.

To mark a channel as independent, follow these steps:

| <b>Keystrokes:</b>  | <b>Action:</b>   |
|---|--|
| 1. Press [Setup].   | Selects Setup menu   |
| 2. Press [1][1] [Enter].  | Selects Channel Attributes display<br>Prompt reads:<br><b>Select channel number(s)</b>                     |
| 3. Enter channel number(s) to be independent and press [S1], <b>Independent</b> . Use [Thru], [And] and [Except] to select multiple channels. | Selects channel<br>Prompt reads:<br><b>Enable/disable independent channel(s) (1 = Enable, 0 = Disable)</b> |
| 4. Press [1], then press [Enter].   | Channel is independent   |

## ***Flipped channels***

The Flip command inverts the output of the channel to which it is applied. A flipped channel outputs at full when set to zero and at zero when set to full.

Use [S2], **Flip**, to mark a channel flipped. The flipped channels will have their outputs inverted. The levels will not appear inverted on the Stage display, but the level sent to the channel is inverted. This is particularly useful for some moving light functions.

For example, flip the output of the channel controlling the pan of one of two moving lights. If you then record both lights' pan control channels to a submaster, the two lights' movements mirror each other.

To mark a channel as flipped, follow these steps:

### **Keystrokes:**

1. Press [Setup].
2. Press [1][1] [Enter].
3. Enter channel number(s) to flip and press [S2], **Flip**. Use [Thru], [And] and [Except] to select multiple channels.
4. Press [1], then press [Enter].

### **Action:**

- Selects Setup menu
- Selects Channel Attributes display  
Prompt reads:  
**Select channel number(s)**
- Selects channel  
Prompt reads:  
**Enable/disable flipped channel(s)**  
**(1 = Enable, 0 = Disable)**
- Channel is flipped

## ***Labeling a channel***

The Channel Attributes display's Label function allows you to assign an alphanumeric label of up to 16 characters to a channel.

To label a channel, follow these steps:

| <b>Keystrokes:</b>   | <b>Action:</b>   |
|--|--|
| 1. Press [Setup].  | Selects Setup menu   |
| 2. Press [1][1] [Enter].   | Selects Channel Attributes display<br>Prompt reads:<br><b>Select channel number(s)</b>   |
| 3. Enter channel number(s) to label and press [Label]. Use [Thru], [And] and [Except] to select multiple channels. | Selects channel to label<br>Prompt reads:<br><b>Type channel label</b><br><b>(F6 = clear to end,</b><br><b>F7 = last channel label,</b><br><b>F8 = next channel label)</b> |
| 4. Use an alphanumeric keyboard to enter the channel's label, then press [Enter].                                  | Channel is labeled   |

## Selecting channels

Using the keypad to set channel levels involves two steps: selecting the channels whose levels you want to modify, then entering output levels.

- To select a single channel, enter the channel number.  
For example, [Channel] [1] selects channel 1.

*Note: When selecting channels, you only need to press [Channel] if the [Channel] LED is not lit.*

- To select two channels that are not consecutively numbered, enter the number of the first channel, then press [And] and enter the number of the second channel.  
For example, [Channel] [1] [And] [7] selects channels 1 and 7.
- To select a group of consecutively numbered channels, enter the number of the first channel, then press [Thru] and enter the last number.  
For example, [Channel] [1] [Thru] [9] selects channels 1, 2, 3, 4, 5, 6, 7, 8, and 9.
- To exclude channels from a selected group of consecutively numbered channels, enter the first channel, press [Thru], enter the last channel, then press [Except] and enter the channels to leave out.  
For example, [Channel] [1] [Thru] [1][5] [Except] [5] [Thru] [1][3] selects channels 1, 2, 3, 4, 14, and 15.
- Use [And], [Except] and [Thru] to select multiple, non-consecutive groups of channels.  
For example, [Channel] [1] [Thru] [5] [And] [8] [Thru] [1][2] [Except] [9] selects channels 1, 2, 3, 4, 5, 8, 10, 11, and 12.

*Hint: If no channels are selected, press [Enter] to select all channels currently at a level above zero.*

Once you have entered your channel selections, you are ready to set channel levels.

## Selecting channels in Flexichannel mode

In Flexichannel mode, only channels that are used in the show appear on the Stage, Blind and Fader displays. When Flexichannel mode is enabled, the [Thru] key functions slightly differently. For example, in normal mode, pressing [1] [Thru] [5] selects all channels from 1 to 5. In Flexichannel mode, pressing [1] [Thru] [5] selects all visible channels from 1 to 5.

To select all channels from 1 to 5, including channels that haven't been used in the show so far, press [1] [Thru] [Thru] [5]. Pressing [Thru] a second time alerts the system to ignore Flexichannel for that channel selection.

*Note: When channels that were used in a show are removed from the show, they remain on the channel list until it is updated. The Purge Flexi softkey on the System Settings display updates the list of used channels. The list is also updated when you load a show from diskette, or when you first turn Flexichannel on. Press [Setup] [1] [Enter] [S1], **Purge Flexi**, to update Flexichannel displays.*

## Setting channel levels

You assign output levels to channels using the basic format [Channel] [#] [At] [#] where the first number is the channel and the second is the level. For example, [Channel] [4] [At] [7][5] sets channel 4 at 75 percent. If you enter a single digit for the level, Insight 2 multiplies it by ten and you must follow it with [Enter]. In other words, [Channel] [4] [At] [1] [Enter] sets channel 4 to 10 percent. To set channel 4 to 1 percent, enter [Channel] [4] [At] [0][1]. You can also use the level wheel, [Full], [Level], or [S8], **Flash**, to set channel levels.

### Level wheel

To set channel levels with the level wheel, select the channels whose levels you want to modify, then use the wheel to set the desired output level. You can also use the wheel to adjust output levels for all active channels.

To set selected channel levels, enter [Channel] [1] [Thru] [5] then move the level wheel to set levels.

To modify all channels currently at a level above zero, press [Enter] then move the level wheel to set levels.

### Full

[Full] sets selected channel levels to 100 percent. For example, press [Channel] [1] [Thru] [5] [Full] to set channels 1, 2, 3, 4, and 5 to 100 percent.

### Level

[Level] sets selected channel levels to the output level assigned to the [Level] key. The default value for [Level] is 100 percent. (See *Chapter 3, Entering system settings*, page 18 for instructions on changing default settings.) For example, if [Level] is set at 75 percent, press [1] [Thru] [5] [Level] to set channels 1, 2, 3, 4, and 5 to 75 percent.

### Flash

Flash sets the selected channel's level to 100 percent if the channel is currently at a level at or below 50 percent. If the channel's level is above 50 percent, **Flash** sets it to zero. Levels set by Flash are only maintained while the key is pressed. For example, press [Channel] [5], then press and hold [S8], **Flash**, to set channel 5 to either 100 or zero.

## Sneak

Sneak is a softkey that you can use to fade channels on stage to a level you choose, in a specific time or to restore channels to the last level at which they were set with a fader or submaster. For example, if you bring up a cue, then change the look, you can use sneak to go back to the look created by the original cue. If you do not indicate a time, the sneak occurs in the default sneak time, set in System Settings.

Follow these steps to use Sneak to set a channel level:

| <b>Keystrokes:</b>  | <b>Action:</b>  |
|---|---|
| 1. Press [Stage].   | Selects Stage display mode  |
| 2. Press [S1], Sneak.   | Selects Sneak mode<br>Prompt reads: <b>Sneak mode - Select channels, then press ENTER to sneak, or AT to select sneak level, or TIME to select sneak time</b> |
| 3. Select the channel(s) you want to sneak and the level to which you want it to fade. For example, press [5] [At] [5]. | Selects channel 5. Sets level at 50 percent<br>Prompt reads: <b>Sneak mode - Select level</b>   |
| 4. Press [Time] and enter the time for the sneak. For example, press [Time] [1][0].                                     | Selects Sneak time of ten seconds<br>Prompt reads: <b>Sneak mode - Select time</b>  |
| 5. Press [Enter].   | Fades channel 5 to 50 percent over ten seconds  |

Follow these steps to restore a channel to its last fader or submaster level:

| <b>Keystrokes:</b>  | <b>Action:</b>  |
|---|---|
| 1. Press [Sneak] and select the channel(s) you want to restore. For example, press [5]. | Selects channel 5 to sneak<br>Prompt reads: <b>Sneak mode - Select channels, then press ENTER to sneak, or AT to select sneak level, or TIME to select sneak time</b> |
| 2. Press [Enter].   | Fades channel 5 back to its most recent cue or sub level  |

*Note: Press [Sneak] [Enter] to restore all channels to their current fader or submaster levels.*

## Channel check

Use a Channel Check to check which channel controls which light. Insight 2 allows you to check channels by selecting a single channel and setting it at a level. Once you have selected a channel you can then advance sequentially through the channels, checking one at a time.

Follow these steps to run a channel check:

| <b>Keystrokes:</b>  | <b>Actions:</b>  |
|---|--|
| 1. Press [Stage].   | Selects Stage display<br>Prompt reads:<br><b>Select channel numbers</b>  |
| 2. Press [Channel] [1].   | Corner reads: <b>Chan 1</b>  |
| 3. Press and hold [S8], <b>Flash</b> .  | Sets channel 1's level to 100 percent if its current level is at or below 50 percent<br>or...<br>Sets channel 1's level to zero if its current level is above 50 percent |
| 4. While holding [S8], press [+] or [-] to select the next or previous channel. | Flashes each channel in turn   |
| 5. Once you have checked all the channels, release [S8], <b>Flash</b> .         |  |

*Note: You may start a channel check with any channel. Substitute the desired channel in step 2.*

*Note: If a channel is Independent, it will not Flash.*

# About

[About] provides you with information about channels. The following pages describe the use of [About] and the information available in the About channel window.

*Note: See page 38 for information on using About Dimmer.*

## About Channel

About Channel provides attribute and status information for a selected channel. To display the About Channel window, follow these steps:

| Keystrokes:                 | Action:  |
|-----------------------------|--|
| 1. Press [About] [Channel]. | Prompt reads:<br><b>About: Select channel number, then press ENTER</b>   |
| 2. Press [6].               | Keypad corner reads:<br><b>Chan 6</b>                                    |
| 3. Press [Enter].           | About Channel window is displayed.<br>Press [Clear] to remove the window |



- **Label:** The channel's label.
- **Attributes:** Whether or not the channel is flipped or independent.
- **First used:** The first cue in which this channel appears.
- **Last used:** The highest numbered cue in which this channel appears.
- **Number of cues:** The total number of cues in which this channel appears.
- **Number of moves:** The total number of cues in which this channel moves.
- **Level:** The channel's current level.
- **Source:** The control device that is providing the channel's level. Possible sources include: **Captured, Fader #, Sub #, DMX In**
- **Parked:** Whether or not the channel is parked.
- **Inhibited:** The inhibitive submaster, if any, which is controlling the level of the channel.
- **Dimmers:** The dimmers assigned to the channel, as space permits.



# chapter 6

## CUES

This chapter includes instructions on recording, modifying and deleting cues.

After you select channels and set their intensity levels, you can store the resulting look as a cue. You can play cues back in a timed fader. Insight 2 allows you to record up to 600 cues per show.

This chapter contains the following sections:

- Cue types
- Record functions
- Creating cues
- Viewing cues
- Working with cues in Stage mode
- Recording a cue in Stage
- Working with cues in Blind mode
- Recording a cue in Blind
- Recording a cue with a single fade time
- Recording a cue with split fade times
- Recording a cue with a wait time
- Recording cues with Link and Follow
- Recording a cue using Solo
- Labeling cues
- Modifying a recorded cue live
- Modifying cue attributes
- Using Update to modify a cue
- Deleting cues
- Copying cues
- Inserting cues
- Cue List

## **Cue types**

[Type] displays the fade type options described below. The menu that appears in Stage omits the effect and subroutine options. Effects and subroutines are explained in their own chapters.

To select a cue fade type in Stage, Blind or Fader modes, press [Type], and enter an option number. If you change a cue's fade type, you must re-record the cue. For example, [Cue] [2] [Type] [2] [Record] [Enter] records cue 2 with an allfade.

If you do not enter a fade type, cues default to crossfade.

### **Crossfade**

In a crossfade cue, channel levels that increase fade to their new level in the assigned upfade time. Channel levels that decrease fade to their new level in the assigned downfade time. The cue starts when you press [Go]. You may use a wait time to delay the start of the upfade or downfade.

### **Allfade**

An allfade cue forces all unused channels to zero intensity when you press [Go] and clears the other fader. Allfade is useful for forcing an end cue when tracking channels. For more information on using allfade cues for tracking, see *Chapter 7 Track*.

### **Subroutine**

A subroutine is a cue that controls the playback of a series of recorded cues. Subroutines are similar to linked cues, except that you have more playback options. For more information on using subroutines, see *Chapter 13, Working with subroutines*.

### **Effects**

An effect cue contains an effect. Effects allow you to assign channels to a series of steps. When you play back the effect, the steps run in assigned chase patterns, or in random order. For more information on using effects, see *Chapter 12, Working with effects*.

## ***Record functions***

Insight 2 has two record functions; Record and Track. Record saves all channels as they appear on the screen (what you see is what you get) in the cue, group or submaster you specify. When you use Record to record a cue, levels are recorded in only one cue.

Track is a record function that works only with cues. It allows you to build a new cue from the previous cue's channel settings. Tracked channels are channels whose levels do not change from one cue to the next. A *track* often runs through several cues for the length of a scene or an act.

Track also allows you to add tracked channels through existing cues. For example, if you have created all cues for a scene, and then decide to add a few new channels to all cues, or adjust the level of a channel throughout the cues, Track lets you do so with one short record command. To do the same thing with Record would require you to add the new channels to each cue individually.

*Note: When a channel level that tracks through a series of cues reaches an Allfade cue, the track ends.*

We use the standard Record function for all cues in this chapter. Instructions for using the Track function are included in *Chapter 7, Track*.

## Creating cues

Insight 2 allows you to save up to 600 cues per show. A cue is a look you have created and recorded, and can replay in a timed fader pair. If your show requires more than 600 cues, you can read a second show from diskette during a break, or between cues. See *Chapter 17, Diskette functions*, for more information about recording shows on diskette.

This chapter includes instructions and examples for creating and modifying cues using several different methods. If you follow the examples, you will have several cues recorded. You will also know how to modify, copy and delete cues.

If you have several cues already stored, you may want to use the look from one cue and modify it to create another. In other circumstances, you may want to enter all channel levels manually.

There are several ways you can go about creating any one look. The following instructions give examples of how you *could* generate each cue.

*Note: Before you clear cues, as described below, make sure that the show currently in the console memory is saved on diskette.*

The examples in this chapter assume there are no cues stored in the console. To erase any cues, press [Setup] [4] [Enter] [2] [Enter] [Enter].

## Viewing cues

You can view stored cues in two ways, live in Stage mode, or just on the screen in Blind mode.

To view cues live, you must select the cue and play it back in a fader. See *Chapter 9, Playing back cues*, for instructions.

To view a cue only on the screen, select Blind mode and enter the desired cue number. To view a different cue, press [Cue] and the new cue number that you want to see.

In Blind mode you can also use [+] and [-] to move through recorded cues, and cue parts, one at a time. Press [Cue]; then press [+] to display the next cue or part; press [-] to display the previous cue or part.

# Working with cues in Stage mode

Stage mode display appears on the Command display monitor. A sample Stage mode display is shown below.

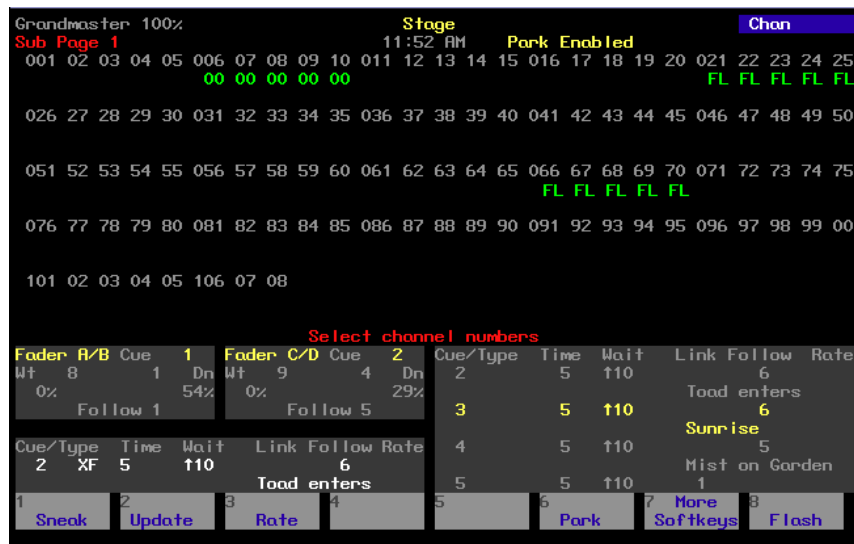

The examples in this chapter demonstrate how to create a variety of cues in Stage display mode. Cues consist of channel levels and cue attributes. Each example in the text illustrates a different cue attribute. However, multiple attributes can be applied to one cue.

## Recording a cue in Stage

In this cue, you will only set channel levels. Default settings will determine all other attributes of the cue. You can change most default settings from the System Settings menu. See *Chapter 3, Entering system settings*, for information about setting and changing defaults.

Follow these steps to record cue 1:

| <b>Keystrokes:</b>  | <b>Action:</b>  |
|---|---|
| 1. Press [Stage].   | Selects Stage display mode<br>Prompt reads:<br><b>Select channel numbers</b>                          |
| 2. Press [1] [Thru] [1][0].   | Selects channels 1 through 10   |
| 3. Press [At].  | Prompt reads: <b>Enter intensity</b>  |
| 4. Press [5][0].  | Sets a level of 50 percent for channels 1 through 10  |
| 5. Press [Record].  | Prompt reads:<br><b>To record cue, select number and press ENTER</b><br><b>To cancel, press CLEAR</b> |
| 6. Press [1].   | Selects cue 1   |
| <i>Note: The keypad defaults to cue mode when you press [Record].</i> |   |
| 7. Press [Enter].   | Records cue 1 containing channels 1 through 10 at 50 percent  |
| 8. Press [Rel].   | Releases captured channels  |

# Working with cues in Blind mode

Blind mode allows you to create, preview or modify cues without affecting the current look on stage. If you prefer to work with live looks, you should work in Stage mode.

When you press [Blind], Insight 2 displays the following screen:

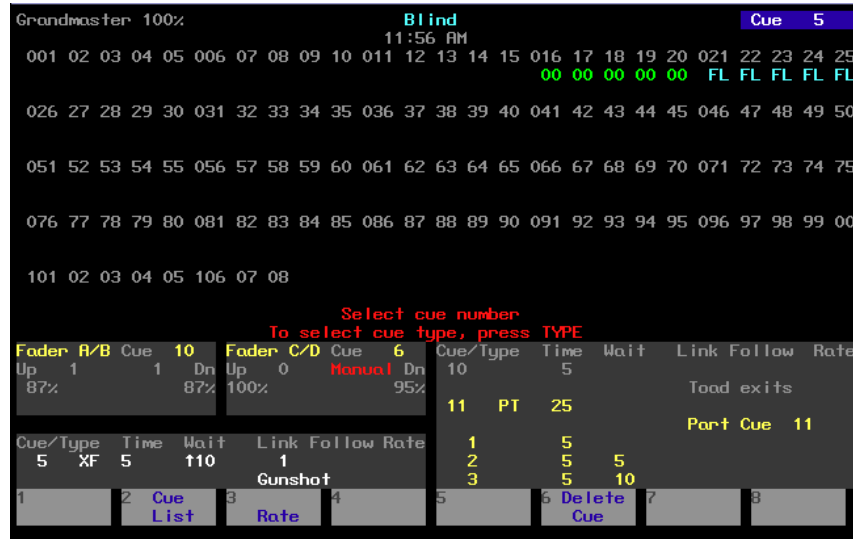

## Recording a cue in Blind

This example creates a cue in Blind mode. Blind allows you to work on cues without affecting the look on stage. Insight 2 automatically enters 00 for channels used in cue 1 to indicate that they will downfade in cue 2.

Follow these steps to record cue 2 in Blind mode:

### Keystrokes:

1. Press [Blind].
2. Press [2].
3. Press [Channel] [1][3].

### Action:

Selects Blind display mode

Prompt reads:

**Select cue number**

**To select cue type, press TYPE**

Selects cue 2

Selects channel 13

Prompt reads:

**Select channel numbers**

Adds channel 15 to your selected channels. Selected channels are displayed in yellow

Sets channels at full intensity level

*Note: When using [Full], you do not have to press [At] first.*

6. Press [Record].

Prompt reads:

**To record cue, select number and press ENTER**

**To cancel, press CLEAR**

7. Press [Enter].

Records cue 2 with channels 13 and 15 at Full

When you record the cue, channel levels set by a fader change from red (indicating a channel level set on the keypad) to colors based on the channels' level movements from cue to cue. See page 6 for more information on what channel level colors mean.

## ***Recording a cue with a single fade time***

Unless you tell it otherwise, Insight 2 assigns default fade times to any cue you record. If you prefer, you may record cues with custom fade times instead.

Fade times can be zero seconds to 99:59 minutes long. They may be expressed in minutes and seconds, or as fractions of seconds (in decimal format). Acceptable time values include: .2 (.2 seconds), 00:12 (12 seconds), 5.5 (5.5 seconds), or 5:30 (five minutes, 30 seconds).

Follow these steps to record a cue with a custom fade time:

| <b>Keystrokes:</b>           | <b>Action:</b>  |
|------------------------------|---|
| 1. Press [Stage] or [Blind]. | Selects display mode  |
| 2. Press [Cue]               | Prompt reads:<br><b>Select cue number</b><br><b>To select cue type, press TYPE</b>                    |
| 3. Press [3]                 | Selects cue 3   |
| 4. Press [Time].             | Prompt reads:<br><b>Enter upfade time</b>   |
| 5. Press [8].                | Enters a fade time of 8 seconds.<br>Corner reads: <b>UpTime 8</b>                                     |
| 6. Press [Enter] [Enter].    | Enters matching downfade time   |
| 7. Press [Record].           | Prompt reads:<br><b>To record cue, select number and press ENTER</b><br><b>To cancel, press CLEAR</b> |
| 8. Press [Enter]             | Records cue 3 with fade time of eight seconds   |

*Note: If the cue already exists, you may omit steps 7 and 8.*

## Recording a cue with split fade times

Insight 2 allows you to record cues with different upfade and downfade times. These cues are said to have *split* fade times. On the Insight 2 display, the time to the left of the / refers to the upfade time; the number to the right refers to the downfade time.

Follow these steps to record a cue with split upfade and downfade times:

| <b>Keystrokes:</b>           | <b>Action:</b>  |
|------------------------------|---|
| 1. Press [Stage] or [Blind]. | Selects display mode  |
| 2. Press [Cue]               | Prompt reads:<br><b>Select cue number</b><br><b>To select cue type, press TYPE</b>                    |
| 3. Press [4]                 | Selects cue 4<br>Corner reads: <b>Cue 4</b>   |
| 4. Press [Time].             | Prompt reads:<br><b>Enter upfade time</b>   |
| 5. Press [1][0].             | Enters an upfade time of ten seconds<br>Corner reads: <b>UpTime 10</b>                                |
| 6. Press [Enter].            | Prompt reads:<br><b>Enter downfade time</b>   |
| 7. Press [1][5].             | Enters a downfade time of 15 seconds<br>Corner reads: <b>DnTime 15</b>                                |
| 8. Press [Record].           | Prompt reads:<br><b>To record cue, select number and press ENTER</b><br><b>To cancel, press CLEAR</b> |
| 9. Press [Enter].            | Records cue 4 with upfade time of ten seconds and downfade time of 15 seconds                         |

*Note: If the cue already exists, you may omit steps 8 and 9.*

## ***Recording a cue with a wait time***

Wait time is the time that elapses between when you press [Go] and when the actual fade begins. You can record Insight 2 cues with a wait time of up to 99:59 minutes. Insight 2 allows you to program a wait time for either the upfade or the downfade; not both. If you do not enter a wait time, Insight 2 assigns the cue a wait time of zero.

Follow these steps to record a cue with a downfade wait time:

| <b>Keystrokes:</b>                                   | <b>Action:</b>  |
|--|---|
| 1. Press [Stage] or [Blind].                         | Selects display mode  |
| 2. Press [Cue]                                       | Prompt reads:<br><b>Select cue number</b><br><b>To select cue type, press TYPE</b>                |
| 3. Press [5]   | Selects cue 5   |
| 4. Press [Wait] once<br>or...<br>Press [Wait] twice. | Prompt reads:<br><b>Enter upfade wait time</b><br>or...<br><b>Enter downfade wait time.</b>       |
| 5. Press [6].  | Enters a wait time of six seconds<br>Corner reads:<br><b>UpWait 6</b><br>or...<br><b>DnWait 6</b> |
| 6. Press [Enter].                                    | Records cue 5 with wait time of six seconds   |

## Recording cues with Link and Follow

When you record a cue, it automatically becomes part of the Cue List. The Cue List is a list of all cues, organized in numeric sequence. Normally, when you press [Go] to execute cues, Insight 2 plays them back in the sequence in which they appear in the Cue List. [Link] allows you to modify the sequence in which cues play back. [Follow] allows you to play back multiple cues automatically.

### Link

Normally, pressing [Go] plays back cues in the sequence indicated on the Cue List. [Link] allows you to play back cues out of sequence by linking them together. For example if you link cue 6 to cue 2, then play cue 6, pressing [Go] plays cue 2.

Follow these steps to record a linked cue.

| Keystrokes:                  | Action:   |
|------------------------------|---|
| 1. Press [Stage] or [Blind]. | Selects display mode  |
| 2. [Cue] [6].                | Selects cue 6   |
| 3. Press [Link].             | Prompt reads:<br><b>To link to cue, select cue number<br/>To link to macro, press ENTER<br/>MACRO</b> |
| 4. Press [2] [Enter].        | Links cue 6 to cue 2. After you play back cue 6, press [Go] to play back cue 2                        |

*Note: You can also link cues to macros. For more information on linking cues to macros, see page 170 in Chapter 15, Working with macros.*

### Follow

[Follow] allows you to play a series of cues automatically. The [Follow] time indicates how long the console waits after the cue starts before the next cue runs. [Follow] plays back the next cue on the Cue List unless you use [Link] to specify a different sequence.

Follow times may be expressed in minutes and seconds, or as fractions of seconds, up to 99:59 minutes.

Follow these steps to record a cue with [Follow].

| Keystrokes:                  | Action:  |
|------------------------------|--|
| 1. Press [Stage] or [Blind]. | Selects display mode   |
| 2. Press [Cue] [7].          | Selects cue 7  |
| 3. Press [Follow].           | Prompt reads:<br><b>Enter follow time (or press ENTER<br/>to confirm default time)</b>   |
| 4. Press [5] [Enter].        | Records cue 7 with a Follow time of five seconds. After you start cue 7, the next cue in the Cue List plays automatically five seconds later |

## ***Combining Link and Follow to create playback loops***

Insight 2 allows you to use Link and Follow to create cue playback sequences in which a group of cues plays back automatically and repeats.

Follow these steps to create a five-cue sequence:

| <b>Keystrokes:</b>  | <b>Action:</b>  |
|---|---|
| 1. Create five cues numbered 1, 2, 3, 4, and 5.   | Cue list displays cues 1 through 5                          |
| 2. Press [Cue], then press [1], the number of the first cue you want to include in the playback loop. | Selects the first cue                                       |
| 3. Press [Follow] [5] [Enter].  | Assigns a follow time of five seconds to the first cue      |
| 4. Repeat steps 2 and 3 for cues 2 through 5.   | Assigns a follow time of five seconds to the remaining cues |
| 5. Press [Cue], then press [5], the number of the last cue in the playback loop.                      | Selects the last cue in the playback loop                   |
| 6. Press [Link], then press [1], the number of the first cue in the playback loop. Press [Enter].     | Creates a loop by linking the last cue to the first cue     |

*Note: You may also use effects to create loops. See Chapter 12, Effects, for more information.*

## ***Using Link to link a macro to a cue***

[Link] allows you to automatically run a macro when a cue runs. If you want the macro to delay before running, start the macro with a Macro Wait of the desired length. See *Chapter 14, Macros*, for information about creating macros.

Follow these steps to link a macro to a cue:

| <b>Keystrokes:</b>           | <b>Action:</b>  |
|------------------------------|---|
| 1. Press [Stage] or [Blind]. | Selects display mode  |
| 2. [Cue] [6].                | Selects cue 6   |
| 3. Press [Link].             | Prompt reads:<br><b>To link to cue, select cue number</b><br><b>To link to macro, press ENTER</b><br><b>MACRO</b> |
| 4. Press [Enter Macro]       | Prompt reads:<br><b>To link to macro, select macro number</b><br><b>To link to cue, press CUE</b>                 |
| 5. Press [7] [Enter].        | Records cue 6 linked to macro 7. When you press [Go] to play cue 6, macro 7 will run at the same time             |

## Recording a cue using Solo

[Solo] lets you record a cue that contains some of the channels that make up the current look, but not others. Often you will create cues by adding to, subtracting from and modifying previously recorded cues.

Follow these steps to create a cue using Solo:

| <b>Keystrokes:</b>   | <b>Action:</b>   |
|--|--|
| 1. Press [Stage] or [Blind].   | Selects display mode   |
| 2. Press [Channel].  | Prompt reads:<br><b>Select channel numbers</b>   |
| 3. Press [2][0].   | Enters channel number to mark the start of the selected range  |
| 4. Press [Thru].   | Indicates you are selecting a range of channels  |
| 5. Press [3][0]  | Selects channels 20 through 30   |
| 6. Press [Solo].   | Sets all channels other than 20 through 30 to zero<br>Prompt reads:<br><b>(To restore levels, press SOLO)</b><br><b>Select channel numbers</b> |
| 7. Move fader wheel; press [Full], [Level], [+], or [-]; or use [At] and numeric keypad to set levels for selected channels. | Sets channels 60 through 70 to a new level   |
| 8. Press [Record].   | Prompt reads:<br><b>To record cue, select number and press ENTER</b><br><b>To cancel, press CLEAR</b>  |
| 9. Press [7].  | Corner reads: <b>Cue 7</b>   |
| 10. Press [Enter].   | Records cue 7 with channels 60 through 70  |
| 11. Press [Solo].  | Restores channels other than 60 through 70 to previous levels  |

*Warning: If you press [Solo] in Stage mode, unselected channels controlling lights on stage will go to zero.*

## Labeling cues

Insight 2 allows you to use an alphanumeric keyboard to assign labels to cues. Labels can consist of any combination of letters, numbers and symbols and may be up to 16 characters long. See page 282 for information on installing an alphanumeric keyboard.

Follow these steps to label a cue:

- | <b>Keystrokes:</b>   | <b>Action:</b>   |
|--|--|
| 1. Press [Stage] or [Blind].   | Selects display mode   |
| 2. Press [Cue] [1][2] [Label].   | Selects Cue 12<br>Prompt reads:<br><b>Type cue label</b><br><b>(F6 = clear to end,</b><br><b>F7 = last cue label,</b><br><b>F8 = next cue label)</b> |
| 3. Use the alphanumeric keyboard to type the desired label. For example, call cue 12 "Toad exits." | Enters cue label<br>Corner reads: <b>Label Toad exits</b>  |
| 4. Press [Enter].  | Records Cue 12 with label "Toad exits"   |

*Note: If the cue did not previously exist, press [Record] [Enter] in step 4. This will create the cue and label it as indicated, all in one step.*

## Modifying a recorded cue live

All the preceding examples have involved creating a new cue. In Stage, if you want to add, remove or modify channel levels, you must play back the cue, make your changes, then re-record the cue. If you are changing cue attributes, you do not need to play back the cue.

### Modifying channels in a cue

If you are not familiar with procedures for playing back cues, see *Chapter 9 Playing back cues*. Follow these steps to modify cues in Stage mode:

| Keystrokes:   | Action:   |
|---|---|
| 1. Press [Stage].   | Selects Stage display mode  |
| 2. Press [Cue], enter cue number and press [Go].                                  | Plays back selected cue   |
| 3. Select channels and set channel levels to make the desired changes to the cue. | Modifies cue channel levels   |
| 4. Press [Record] [Enter].<br>or...<br>Press [Record] [8] [Enter].                | Re-records cue with desired modifications<br>or...<br>Records the modified cue as cue 8 |

*Note: If you re-record as the same cue, modifications affect the look on stage. If you record the cue with a new number, modifications are not reflected in the fader; you may want to run the cue through a fader before you release channels if you don't want to lose the look from stage.*

### Modifying cue attributes

Follow these steps to modify cue attributes:

| Keystrokes:   | Action:                           |
|---|-----------------------------------|
| 1. Press [Stage] or [Blind].  | Selects display mode              |
| 2. Press [Cue] then enter the number of the desired cue.  | Selects the desired cue           |
| 3. Press the key that corresponds to the attribute you want to modify. Options include: Type*, Time, Wait, Link, Follow, and Label. |                                   |
| 4. Enter the new setting for the attribute.   | Modifies cue attribute            |
| 5. Press [Enter].   | Re-records cue with modifications |

*\* Note: if you change the cue's type, press [Record] [Enter] in step 5. Type changes will not take effect unless recorded.*

## Using Update to modify channels in a cue

The Update feature allows you to easily record changed levels on Stage into a selected cue. You may record all levels on Stage into the cue, or you may record only changes to channels that were previously recorded in the cue. This allows you to modify the channel levels in the active cue, then re-record the cue without recording the entire stage look.

*Note: Levels provided by submasters aren't updated. Only channel levels set on the keypad are recorded.*

Follow these steps to use Update to modify a cue in Stage mode:

| <b>Keystrokes:</b>   | <b>Action:</b>  |
|--|---|
| 1. Press [Stage].  | Selects Stage display mode  |
| 2. Press [Cue], enter cue number and press [Go].   | Plays back selected cue, bringing up its current levels   |
| 3. Modify channel levels as desired.   |   |
| 4. Press [S2], <b>Update</b> .<br>(If you wish to update the levels in a cue other than the active cue, enter the desired cue number.) | Prompt reads:<br><b>To update cue, select number and press ENTER</b><br><b>(TRACK + ENTER for tracking)</b><br><b>(Press ONLY + ENTER to update only those channels already in cue)</b> |
| 5. To record changes only to channels that are already in the cue, press [Only].   | Limits update to channels in cue  |
| 6. Press [Enter]<br>or...<br>Press [Track] [Enter].  | Updates and re-records the active cue   |

*Note: Press [Track] after you press [S2], **Update**, if you wish changes to track into subsequent cues.*

## Using Update to add channels to a cue

Normally when you re-record a cue, you record all the channel levels currently on stage. Insight 2's Update feature allows you to record only those channels that you specify.

This allows you to add specific channels to the active cue, then re-record the cue without recording the entire stage look.

Follow these steps to use Update to modify a cue in Stage mode:

| <b>Keystrokes:</b>   | <b>Action:</b>   |
|--|--|
| 1. Press [Stage].  | Selects Stage display mode   |
| 2. Press [Cue], enter cue number and press [Go].   | Plays back selected cue, bringing up its current levels  |
| 3. Modify or add channel levels as desired.  |  |
| 4. Press [S2], <b>Update</b> .<br>(If you wish to update the levels in a cue other than the active cue, enter the desired cue number.) | Prompt reads:<br><b>To update cue, select number and press ENTER</b><br><b>(TRACK + ENTER for tracking)</b><br><b>To cancel, press clear</b> |
| 5. Press [Channel].  | Prompt reads:<br><b>To update channel(s), select number(s) and press ENTER</b><br><b>To cancel, press clear</b>                              |
| 6. Enter the channel number(s) you wish to add to, or update in, the cue.  |  |
| 7. Press [Enter]<br>or...<br>Press [Track] [Enter].  | Updates and re-records the active cue  |

*Note: Press [Track] instead of [Enter] in step 7 if you wish changes to track into subsequent cues.*

## ***Using Update to modify fade rate***

You may also use the Update function to record manually modified fade rates into cues.

Follow these steps to update a rate for a cue running in a fader:

| <b>Keystrokes:</b>   | <b>Action:</b>  |
|--|---|
| 1. Press [Rate] key for the fader in which the cue is running. | Activates rate control  |
| 2. Move rate wheel to adjust fade rate.                        | Fades are placed under control of the rate wheel. The Fader Status window shows the current rate  |
| 3. Press [S2], <b>Update</b> .                                 | Prompt reads:<br><b>To update cue, select number and press ENTER (TRACK + ENTER for tracking) (Press ONLY + ENTER to update only those channels already in cue)</b> |
| 4. Press [Enter].  | New rate is recorded into cue   |

## Deleting cues

Follow these steps to delete a cue in Stage or Blind mode.

| <b>Keystrokes:</b>   | <b>Action:</b>   |
|--|--|
| 1. Press [Stage] or [Blind]. If you press [Stage], press [S7], <b>More Softkeys</b> .  | Selects display mode   |
| 2. Press [S6], <b>Delete</b> in Stage, <b>Delete Cue</b> in Blind).  | Prompt reads:<br><b>To Delete cue, press ENTER - Delete cue and tracking, press TRACK + ENTER</b><br><b>To cancel, press CLEAR</b> |
| 3. Enter number of cue to delete. This is optional if you wish to delete the currently selected cue.   | Selects cue to delete  |
| 4. To delete just the current cue, press [Enter].<br><br>To delete the current cue and any channels that track from that cue, press [Track] [Enter]. | Prompt reads:<br><b>To confirm, press ENTER</b><br><b>To cancel, press CLEAR</b>   |
| 5. Press [Enter]   | Deletes cue  |

For more information on tracking, see *Chapter 7, Track*, page 79.

## Copying cues

In some cases, you may want to copy a cue's channel levels and use them as the foundation for a new cue. To copy cue, follow these steps:

| <b>Keystrokes:</b>                          | <b>Actions:</b>   |
|---|---|
| 1. Press [Stage] or [Blind].                | Selects display mode  |
| 2. Press [Cue] [1].                         | Prompt reads:<br><b>Select cue number</b><br><b>To select cue type, press TYPE</b>                        |
| 3. If you are in Stage display, press [Go]. |   |
| 4. Press [Record].                          | Prompt reads:<br><b>To record cue, select number and press ENTER</b><br><b>To cancel, press CLEAR</b>     |
| 5. Press [Cue] [2].                         | Corner reads: <b>Cue 2</b>  |
| 6. Press [Enter].                           | Cue copy is complete. Channel levels have been copied from cue 1 to cue 2. You can now modify the new cue |

*Note: You may also copy a look from a cue to a submaster or a group. To do so, press [Sub] or [Group] in place of [Cue] in step 5.*

## Inserting cues

You may want to insert a cue between recorded cues. For example, you may want to modify cue 1 slightly and insert it between cues 1 and 2. You can number cues with a one-digit decimal. Therefore, you can insert up to nine cues between 1 and 2 (1.1, 1.2, etc.).

Follow these steps to insert a cue between existing cues:

| <b>Keystrokes:</b>   | <b>Action:</b>  |
|--|---|
| 1. Press [Blind] or [Stage].   | Selects display mode  |
| 2. Press [Cue] and enter the number of the cue to modify, then press [Enter].  | Selects the desired cue   |
| 3. If you are working in Stage mode, press [Go].   | Brings up cue on stage and on the display   |
| 4. Add or modify channels and cue attributes.  | Cue is modified   |
| 5. Press [Record].   | Prompt reads:<br><b>To record cue, select number and press ENTER</b><br><b>To cancel, press CLEAR</b> |
| 6. Enter cue number with a decimal to insert it between cues (e.g., [1].[5]). If you do not enter a new cue number, you will overwrite the existing cue. | Corner reads: <b>Cue 1.5</b>  |
| 7. Press [Enter].  | New cue 1.5 is recorded between cues 1 and 2  |

# Cue List

The Blind Cue List displays a list of the cues in your show. Up to 18 cues are displayed on screen at any time. The Cue List includes the cue number and type, its upfade, downfade and wait times, its link and follow settings, its rate, and its label.

Press [S2], **Cue List**, in Blind mode to display the Cue List. A sample Cue List display is shown below:

| Cue/Type | Up/Down | Wait | Link | Follow | Rate | Label       |
|----------|---------|------|------|--------|------|-------------|
| 1        | 2       | 3    | ↑1   |        | 3    | Cue 1       |
| 2        | 5       | ↑1   |      | 6      |      | Cue 2       |
| 3        | 5       | ↓1   |      | 6      |      | Cue 3       |
| 4        | 5       |      |      | 5      |      | Cue 4       |
| 5        | 5       |      | 1    |        |      | Cue 5       |
| 10       | 5       |      |      |        |      | Cue 10      |
| 11       | PT      | 25   |      |        |      | Part Cue 11 |
| 1        | 2       | 5    |      |        |      |             |
| 2        | 5       | 5    |      |        |      |             |
| 3        | 5       | 10   |      |        |      |             |
| 4        | 5       | 15   |      |        |      |             |
| 5        | 5       | 20   |      |        |      |             |
| 31       | 5       | ↑10  |      |        |      | C31         |
| 32       | 5       |      |      |        |      | C32         |
| 33       | 5       |      |      |        |      | C33         |
| 34       | 5       |      |      |        |      | C34         |
| 35       | 5       |      |      |        |      | C35         |
| 36       | 5       |      |      |        |      | C36         |

Select cue number(s)

|       |      |      |               |           |            |    |        |
|-------|------|------|---------------|-----------|------------|----|--------|
| S1    | S2   | S3   | S4            | S5        | S6         | S7 | S8     |
| Dwell | Hold | Rate | Previous Page | Next Page | Delete Cue |    | Return |

Follow this example to modify a cue in Cue List display:

### Keystrokes:

1. Press [Blind].
2. Press [S2], **Cue List**.
3. Use the keypad to enter the cue(s) to modify. Use [And], [Except] and [Thru] to select multiple cues.
4. Press [→] until the cursor reaches the attribute you wish to edit.
5. Enter the new setting for the attribute and press [Enter].

### Action:

- Selects Blind display mode
- Displays Cue List
- Selects desired cue(s)  
Prompt reads:  
**Select cue number(s)**
- The prompt indicates your options or prompts you to enter a new setting
- Setting change is reflected on cue list

## ***Editing cue attributes in Cue List***

The Cue List allows you to edit attributes across a range of cues simultaneously.

For example, if you wanted cues 1 through 5 to have upfade wait times of ten seconds, you could set them all in one command. Follow these steps to do so:

### **Keystrokes:**

1. Press [Blind] [S2], **Cue List**.
2. Press [1] [Thru] [5].
3. Press [Wait].
4. Press [1][0] [Enter].

### **Actions:**

- Displays Cue List  
Prompt reads:  
**Select cue number(s)**
- Selects cues 1 through 5
- Prompt reads:  
**Enter upfade wait time**
- Sets upfade wait time for cues 1 through 5 to **10**



# chapter 7

## track

### **Track record function**

Track record allows you to record cues and modify recorded cues. Additionally, it allows you to designate whether or not the levels in the displayed cue should track into subsequent cues until a new level instruction is encountered.

It also allows you to modify groups of cues quickly and add channels to cues. You can also use it to create a new cue from the previous one, by pulling all levels forward into the Blind display of the new cue.

### **Tracksheet mode**

Tracksheet displays one channel's level settings for all cues in which it appears. From it, you can follow the track of that channel quickly. You can then select a cue or a group of cues from the Tracksheet and modify that channel's level throughout. Tracksheet provides one means for tracking channels through allfade cues.

## ***Track record***

When you record a series of cues, you typically record the first cue, then build the second cue from the first. Some of the channels change, but many remain the same. The third cue is built from the second and so on. This procedure results in many channels being set to a level in one cue and staying at that level for several cues.

A channel whose level does not change through a series of consecutive cues is said to “track” from cue to cue. That same sequence of unchanged levels is also referred to as a “track.” The [Track] key creates tracks by pulling channel levels from the previous cue (in Blind mode), or by adding tracks to existing cues (in either Blind, Stage or Tracksheet).

Rising channel levels are displayed in blue in the Blind display. Falling channel levels are displayed in green. Channel levels displayed in magenta indicate that the channel is tracking, i.e., that its level is the same as in the previous cue.

The following examples demonstrate how Track works. They include five cues, each with five channels. In these examples, when a channel changes level from one cue to the next it is printed in **bold**; tracked channels are printed normally. This corresponds to how Blind displays levels – channels that rise or fall are displayed in blue or green; tracked channels are displayed in magenta.

## Using record to create tracks

In Stage mode, the following keystrokes create the five cues illustrated below. Each cue adds channels to the previous cue. The example uses [Record] to record the cues.

```
Cue 1 [Chan] [1] [Full] [Record] [1] [Enter]
Cue 2 [Chan] [2] [Full] [Record] [2] [Enter]
Cue 3 [Chan] [3] [Full] [Record] [3] [Enter]
Cue 4 [Chan] [1] [At] [2][5] [Chan] [4] [Full] [Record] [4] [Enter]
Cue 5 [Chan] [1] [Thru] [4] [At] [0][0] [Record] [5] [Enter]
```

These keystrokes produce the results illustrated in Figure 1.

---

|       | Chan 1    | Chan 2    | Chan 3    | Chan 4    | Chan 5 |
|-------|-----------|-----------|-----------|-----------|--------|
| Cue 1 | <b>FF</b> |           |           |           |        |
| Cue 2 | FF        | <b>FF</b> |           |           |        |
| Cue 3 | FF        | FF        | <b>FF</b> |           |        |
| Cue 4 | <b>25</b> | FF        | FF        | <b>FF</b> |        |
| Cue 5 | <b>00</b> | <b>00</b> | <b>00</b> | <b>00</b> |        |

---

Figure 1

Notice the vertical tracks that develop when a channel remains at the same level through a number of cues. For example, channel 1 tracks from cue 1 to cue 3. When a channel is not set at any level (such as channel 5 above) it is considered tracked at clear.

## Recording modified cues

The difference between Record and Track is apparent when you modify a cue or insert a new cue between two existing cues. Record and Track produce different results.

The following keys were pressed to release captured channels and play back cue 1.

[Stage] [Rel] [Rel]      Release captured channels.  
[Cue] [1] [Go]          Play back cue 1.  
[Chan] [1] [At] [5][0]    Modify channel 1 to 50 percent.

With cue 1 in a fader, channel 1 is modified to 50 percent. To change a channel level that affects only the cue you modify, use [Record]. Modify the cue; press [Record]; enter the cue number, and press [Enter]. Only the current cue is modified. The track that encompasses the channel is interrupted but continues in the following cues at the originally tracked level.

The results of modifying cue 1 and using [Record] are illustrated in Figure 2.

---

|       | Chan 1    | Chan 2    | Chan 3    | Chan 4    | Chan 5 |
|-------|-----------|-----------|-----------|-----------|--------|
| Cue 1 | <b>50</b> |           |           |           |        |
| Cue 2 | <b>FF</b> | <b>FF</b> |           |           |        |
| Cue 3 | FF        | FF        | <b>FF</b> |           |        |
| Cue 4 | <b>25</b> | FF        | FF        | <b>FF</b> |        |
| Cue 5 | <b>00</b> | <b>00</b> | <b>00</b> | <b>00</b> |        |

---

Figure 2

Note that channel 1 is not affected in cues 2 and 3. Also note that when you record a modified cue that is in a playback fader, the changes are reflected in the fader. That is, when you release the channels you have modified, they remain on stage.

If you change the level in the beginning or middle of a track, you may want the change to continue through the remainder of the original track. To track the level modification we just recorded in the example above, use [Track] instead of [Record] to modify channel 1. Press [Track], enter cue number, and press [Enter]. If you use [Track] rather than [Record] to record the changes made to the cue illustrated in Figure 1, the results will be as illustrated in Figure 3 (versus the results from using [Record] illustrated in Figure 2).

---

|       | Chan 1    | Chan 2    | Chan 3    | Chan 4    | Chan 5 |
|-------|-----------|-----------|-----------|-----------|--------|
| Cue 1 | <b>50</b> |           |           |           |        |
| Cue 2 | 50        | <b>FF</b> |           |           |        |
| Cue 3 | 50        | FF        | <b>FF</b> |           |        |
| Cue 4 | <b>25</b> | FF        | FF        | <b>FF</b> |        |
| Cue 5 | <b>00</b> | <b>00</b> | <b>00</b> | <b>00</b> |        |

---

*Figure 3*

The modified level is recorded in the current cue and carries through the entire track (cues 1 through 3).

## Inserting cues

If you insert a cue in this sequence, Record and Track produce different results. Record saves changes only in the cue you insert; Track saves the changes you make and tracks them through the following cues.

The following keys were pressed to release captured channels and play back cue 1. With cue 1 in a fader, channel 4 is added at 50 percent. The new look is inserted as cue 1.1.

|                            |                              |
|----------------------------|------------------------------|
| [Stage] [Rel] [Rel]        | Release captured channels.   |
| [Cue] [1] [Go]             | Play back cue 1.             |
| [Chan] [4] [At] [5][0]     | Add channel 4 at 50 percent. |
| [Record] [1][.][1] [Enter] | Inserts new look as cue 1.1. |

Figure 4 displays the result inserting the cue using [Record]. Notice the new channel is not added to the cues that follow it.

---

|         | Chan 1    | Chan 2    | Chan 3    | Chan 4    | Chan 5 |
|---------|-----------|-----------|-----------|-----------|--------|
| Cue 1   | <b>50</b> |           |           |           |        |
| Cue 1.1 | 50        |           |           | <b>50</b> |        |
| Cue 2   | 50        | <b>FF</b> |           | <b>00</b> |        |
| Cue 3   | 50        | FF        | <b>FF</b> |           |        |
| Cue 4   | <b>25</b> | FF        | FF        | <b>FF</b> |        |
| Cue 5   | <b>00</b> | <b>00</b> | <b>00</b> | <b>00</b> |        |

---

Figure 4

Note that Insight 2 enters a level of 00 percent for channel 4 in cue 2. This fades channel 4 out when cue 2 is played.

When you insert a cue with [Track], new channels track through the cues after it until Insight 2 encounters a cue with a level previously recorded for that channel.

Pressing [Track] (rather than [Record] as in the previous example) then [1][.] [1] [Enter] to insert and record the same cue 1.1 as above produces the results illustrated in Figure 5. Compare it to the results illustrated in Figure 4, in which the same cue was inserted using [Record] rather than [Track].

---

|         | Chan 1    | Chan 2    | Chan 3    | Chan 4    | Chan 5 |
|---------|-----------|-----------|-----------|-----------|--------|
| Cue 1   | <b>50</b> |           |           |           |        |
| Cue 1.1 | 50        |           |           | <b>50</b> |        |
| Cue 2   | 50        | <b>FF</b> |           | 50        |        |
| Cue 3   | 50        | FF        | <b>FF</b> | 50        |        |
| Cue 4   | <b>25</b> | FF        | FF        | <b>FF</b> |        |
| Cue 5   | <b>00</b> | <b>00</b> | <b>00</b> | <b>00</b> |        |

---

*Figure 5*

Channel 4 creates a track from the cue after 1.1 until a pre-recorded level interrupts it.

## ***Blackout cues and tracking***

Sometimes you may add a channel to a sequence of cues that has not used that channel yet. For example, you may want to add a channel to all cues in a scene. To do this, add the channel to the first cue in the sequence, and use Track to track the change through the remaining cues.

However, the last cue in sequence may be a blackout cue. When you track the channel, the new channel tracks until it runs into a different recorded level. To ensure that channels are not tracked through a blackout cue, make the blackout cue an allfade cue. An allfade cue assigns a level of zero to any unused channels. This blocks any potential tracks. An allfade cue also clears the opposite fader.

Figure 6 displays what happens when we track channel 5 through the sequence when cue 5 is a regular crossfade cue.

---

|         | Chan 1    | Chan 2    | Chan 3    | Chan 4    | Chan 5    |
|---------|-----------|-----------|-----------|-----------|-----------|
| Cue 1   | <b>50</b> |           |           |           | <b>FF</b> |
| Cue 1.1 | 50        |           |           | <b>50</b> | FF        |
| Cue 2   | 50        | <b>FF</b> |           | <b>00</b> | FF        |
| Cue 3   | 50        | FF        | <b>FF</b> |           | FF        |
| Cue 4   | <b>25</b> | FF        | FF        | <b>FF</b> | FF        |
| Cue 5   | <b>00</b> | <b>00</b> | <b>00</b> | <b>00</b> | FF        |

---

*Figure 6*

Channel 5 tracks through cue 5 and ruins the blackout cue.

If cue 5 is an allfade, Insight 2 records all unused channels at 00 percent. In the example below, an allfade enters 00 in channel 5, cue 5. When you track channel 5 through the sequence, it won't track through the blackout cue.

To select the allfade type for cue 5, enter these keystrokes:

[Blind] [Cue] [5] [Type] [2]      Selects allfade fade type.  
 [Record] [5] [Enter]              Re-records cue.

Now when we track channel 5 through the sequence, cue 5 blocks the track. The result is illustrated in Figure 7.

---

|         | Chan 1    | Chan 2    | Chan 3    | Chan 4    | Chan 5    |
|---------|-----------|-----------|-----------|-----------|-----------|
| Cue 1   | <b>50</b> |           |           |           | <b>FF</b> |
| Cue 1.1 | 50        |           |           | <b>50</b> | FF        |
| Cue 2   | 50        | <b>FF</b> |           | <b>00</b> | FF        |
| Cue 3   | 50        | FF        | <b>FF</b> |           | FF        |
| Cue 4   | <b>25</b> | FF        | FF        | <b>FF</b> | FF        |
| Cue 5   | <b>00</b> | <b>00</b> | <b>00</b> | <b>00</b> | <b>00</b> |

---

*Figure 7*

For more information on cue fade types, see *Cue types* on page 56.

# Tracksheet

Tracked channels are channels whose levels do not change from one cue to the next. Tracksheet allows you to display one channel's settings for all recorded cues. At a glance you can see which cues have tracking levels for that particular channel. You can also use Tracksheet to add or modify a tracked channel through recorded cues.

To display Tracksheet, press [Tracksheet]. Step-by-step instructions for using Tracksheet are on the following pages. If more cues are recorded than fit on one screen, press [S5], **Next Page**, to display the next screen of cues.

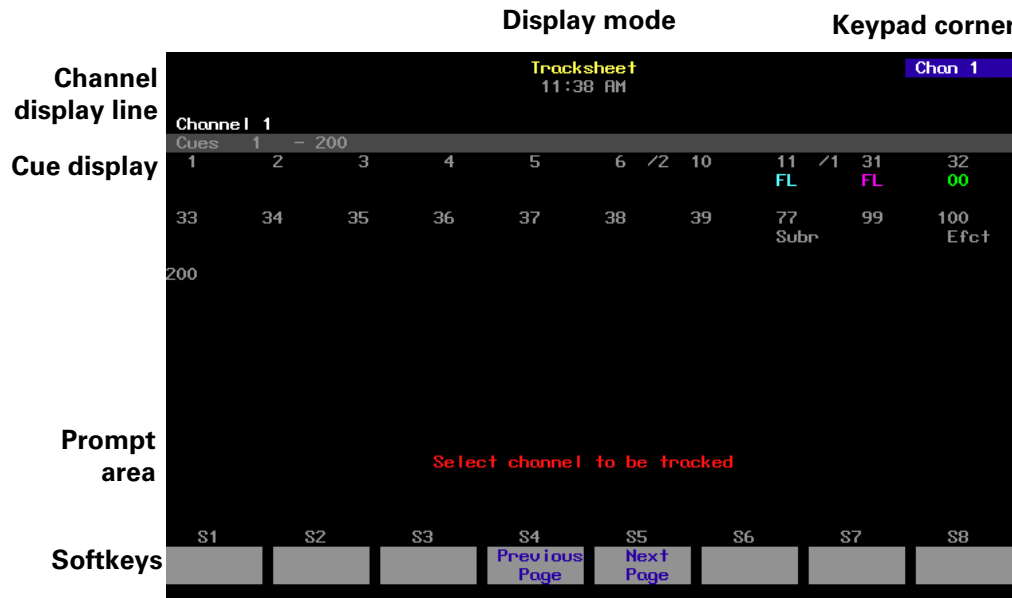

## Keypad corner

This window indicates how the console will interpret the next number entered from the keypad. For example, if you press [Channel], the corner displays **Chan**, indicating that the console will read the next number as a channel number.

## Channel display line

This line displays the current channel number and the range of cues displayed.

## Cue display

The cue display lists recorded cues and the level recorded in each.

## Prompt area

The operator prompt displays messages to guide you through Tracksheet functions.

## Using Tracksheet

With Tracksheet, you can track one channel at a time through any group of cues at any level, including zero. Tracksheet is useful when you want to track a channel through blackout cues, or when you want to complete a track that has been blocked.

To track a channel, follow these steps:

| <b>Keystrokes:</b>  | <b>Action:</b>  |
|---|---|
| 1. Press [Tracksheet].  | Displays Tracksheet<br>Prompt reads:<br><b>Select channel to be tracked</b>   |
| 2. Press [5].   | Selects channel 5 as the channel number to track  |
| 3. Press [Cue].   | Prompt reads:<br><b>Select cues to be modified</b>  |
| 4. Press [2] [Thru] [5]. Use [And] and [Thru] to indicate a range or group of cues. Press [+] and [-] to select the next or previous cue. | Selects cues 2 through 5 as the cues that you want to track this channel through. Cue numbers are highlighted in yellow |
| 5. Press [At] [5][0]. You may also use the fader wheel, [+], [-], or [Full] to enter levels.  | Enters 50 percent intensity level.<br>Prompt reads:<br><b>Enter intensity</b>   |
| 6. Press [Record].  | Prompt reads:<br><b>To record, press ENTER</b><br><b>To cancel, press CLEAR</b>   |
| 7. Press [Enter] to record level settings.  | Records tracked channel in selected cues<br>Prompt reads:<br><b>Select channel to be tracked</b>                        |
| 8. To track a different channel, enter the next channel number you want to display.   |   |

*Hint: To track a channel at zero through all cues it is included in, press [Solo]. The channel goes to zero in all cues. Press [Record] or [Enter].*



# chapter 8

## multipart cues

A multipart cue consists of up to eight parts, each of which is essentially an independent cue with its own channel levels and timing information. Parts accept most standard cue attributes, with the exception of Follow and Label, which apply only to the overall cue. You may record a cue as a multipart cue, or record it as a standard, one-part cue and split it later.

Each part of a multipart cue may consist of any number of channels, but a channel may only be included in one part of a multipart cue. If you record a channel in a part and that channel is already included in another part, the channel will be placed in the new part and be removed from the older part automatically.

Upfade and downfade wait times in multipart cues allow you to program fades that do not start immediately when you play the multipart cue. When you press [Go] to start a multipart cue, some parts may start immediately and others may start up to 99:59 minutes later, depending on the assigned wait time. The total duration of a multipart cue is equal to the combined wait and fade times of the longest part.

*Note: Multipart cues can be recorded in either Stage or Blind mode.*

Multipart cues are stored like normal cues in the console's memory and on disk.

This chapter includes the following sections:

- Recording a multipart cue
- Converting a standard cue to a multipart cue
- Wait times in multipart cues
- Editing a multipart cue

## Recording a multipart cue

Follow these steps to record a multipart cue:

| <b>Keystrokes:</b>  | <b>Action:</b>   |
|---|--|
| 1. Press [Stage].   | Selects Stage display mode   |
| 2. Press [Channel], select channels and enter channel levels, then press [Enter]. For example, [Channel] [1] [Thru] [5] [Full].   | The Prompt reads:<br><b>Select channel numbers</b>   |
| 3. Press [Record], then enter the number of the cue you want to record. For example, press [1][2].  | Indicates that you want to record a cue<br>Prompt reads:<br><b>To record cue, select number and press ENTER</b><br><b>To cancel, press CLEAR</b> |
| 4. Press [Part], then use the keypad to enter the number of the part you want to record. Parts can be assigned a number from 1 to 8 and can be created in any sequence. | Enters the part number to record<br>Prompt reads:<br><b>Select part number to record</b><br><b>To cancel, press CLEAR</b>                        |
| 5. Press [Enter].   |  |
| 6. Repeat steps 2 through 5, adding channels for each part you want to include in the multipart cue.  | Records subsequent parts. Maximum number of parts is eight   |

*Note: You do not need to re-enter the cue number for additional parts. Set channel levels, press [Record] [Part], enter the part number, and press [Enter].*

*Note: Follow, Link and Label attributes may be assigned to the overall cue.*

## Converting a standard cue to a multipart cue

If you have already created a single-part cue, Insight 2 allows you to reconfigure it as a multipart cue. You can convert a standard cue to a multipart cue in either Stage or Blind mode.

As you break the cue into parts to convert it to a multipart cue, Insight 2 automatically creates cue part 8. Any channels not included in the first recorded part are assigned to part 8 automatically. As channels are assigned to new parts, they are deleted from part 8 automatically.

Press [Channel] [1] [Thru] [2][0] [Full] [Record] [1] [Enter]. This creates a standard cue 1 containing channels 1 through 20 at Full. The following example divides this cue into four parts, numbered 1, 2, 3, and 8, each containing five of the channels in the original cue. Press [Stage] to return and continue.

Follow these steps to convert a standard cue to a multipart cue:

| <b>Keystrokes:</b>   | <b>Action:</b>   |
|--|--|
| 1. Press [Stage] or [Blind].   | Selects display mode   |
| 2. Press [Cue] [1].  | Selects cue 1  |
| 3. Press [Channel] [1] [Thru] [5] [Record] [Part] [1] [Enter].       | Creates part 1. Places channels 1 through 5 in part 1. Remaining channels are placed in part 8             |
| 4. Press [Channel] [6] [Thru] [1][0] [Record] [Part] [2] [Enter].    | Creates part 2. Moves channels 6 through 10 from part 8 to part 2  |
| 5. Press [Channel] [1][1] [Thru] [1][5] [Record] [Part] [3] [Enter]. | Creates part 3. Moves channels 11 through 15 from part 8 to part 3. Part 8 contains channels 16 through 20 |

*Note: When a normal cue is split into a multipart cue, all of the channels assigned to that cue are placed in part 8 initially. From part 8, they are moved to any one of the other seven parts. When all of the channels are assigned to a part, part 8 is deleted automatically.*

## Wait times in multipart cues

You can set individual wait times of up to 99:59 minutes for each part of a multipart cue. The wait time is the delay between when you press [Go] and when the part begins. If no wait is recorded, all parts run simultaneously when you press [Go].

Follow these steps to assign a wait time to a part:

| <b>Keystrokes:</b>                           | <b>Action:</b>   |
|--|--|
| 1. Press [Cue], then enter the cue number.   | Selects cue number<br>Prompt reads:<br><b>Select cue number</b>                  |
| 2. Press [Part], then enter the part number. | Selects part number<br>Prompt reads:<br><b>Select part number</b>                |
| 3. Press [Wait] [1][0].                      | Selects wait time of ten seconds<br>Prompt reads:<br><b>Enter wait time</b>      |
| 4. Press [Enter].                            | Sets wait time for the part to ten seconds. Part will wait ten seconds, then run |

## Editing a multipart cue

Once you have created a multipart cue, you can add or delete parts, add or delete channels from the parts, change channel levels, or change fade and wait times.

### Deleting a part from a multipart cue

Follow these steps to delete a part from a multipart cue in Blind:

| <b>Keystrokes:</b>                 | <b>Action:</b>   |
|------------------------------------|--|
| 1. Press [Blind].                  | Selects Blind display mode   |
| 2. Press [Cue] [4] [Part] [1].     | Prompt reads:<br><b>Select part number</b>   |
| 3. Press [S6], <b>Delete Part.</b> | Prompt reads:<br><b>To delete part, press ENTER –<br/>Delete part &amp; tracking, press TRACK<br/>+ ENTER<br/>To cancel, press CLEAR</b> |
| 4. Press [Enter].                  | Prompt reads:<br><b>To confirm, press ENTER<br/>To cancel, press CLEAR</b>   |
| 5. Press [Enter].                  | Deletes part 1 from cue 4  |

*Note: If channels in your cue are tracking, removing a part may affect subsequent cues. Press [Track] after you enter the part number and before you press [Enter]. This removes channels from subsequent cues if they track from this cue part.*

## ***Adding, deleting and modifying channels***

Follow these steps to edit channels in a multipart cue:

| <b>Keystrokes:</b>  | <b>Action:</b>  |
|---|---|
| 1. Press [Blind].   | Selects Blind display mode  |
| 2. Enter the cue number.  | Prompt reads:<br><b>Select cue number</b><br><b>To select cue type, press TYPE</b>  |
| 3. Press [Part]; then press [+] or [-] until the desired part is displayed.   | Prompt reads:<br><b>Select part number</b>  |
| 4. Press [Channel], and select the desired channels.  | Prompt reads:<br><b>Select channel numbers</b>  |
| 5. Set channel levels. (Use [At], the fader wheel, [Full] or [Level], or [+] and [-]. Press [At] [Clear] to delete the channels.) | If the channels are new, this adds them to the part at the level indicated. If already in the part, this modifies their level |
| 6. Press [Record] [Enter].  | Records the modified part   |

*Note: When you initially display a multipart cue, any channel levels that are tracking from the previous cue are displayed in green; new levels are displayed in blue. When you press [Part] this changes. Channels that make up the selected part are now displayed in blue; channels that make up other parts of the multipart cue are displayed in green (or gray, in Blind).*

## ***Modifying fade and wait times***

If you do not assign fade and wait times to a part, Insight 2 automatically assigns it the default times. See *Setting default fade times* on page 17. No wait time will be recorded. Follow these steps to assign fade and wait times to parts in a multipart cue:

| <b>Keystrokes:</b>   | <b>Action:</b>   |
|--|--|
| 1. Press [Blind].  | Selects Blind display mode   |
| 2. Enter the cue number.   | Prompt reads:<br><b>Select cue number</b><br><b>To select cue type, press TYPE</b> |
| 3. Press [Part]; then press [+] or [-] until the part you want to edit is displayed.   | Prompt reads:<br><b>Select part number</b>   |
| 4. Press [Time].   | Prompt reads:<br><b>Enter upfade time</b>  |
| 5. Enter an upfade time between .1 second and 99:59 minutes and press [Enter].   | Prompt reads:<br><b>Enter downfade time</b>  |
| 6. If you want a downfade time that is different from the upfade, enter the desired time and press [Enter]. If not, just press [Enter].  | Fade times are set for the part  |
| 7. Press [Wait].   | Prompt reads: <b>Enter wait time</b>   |
| 8. Enter wait time and press [Enter]. Wait time is the delay between when you press [Go] and when the part begins. If you do not enter a wait time, Insight 2 assigns a wait time of zero. | Wait time is set for the part  |

# chapter 9

## playing back cues

Insight 2 has two timed faders that allow you to play back recorded cues. Cue selection and playback can be automated, or you can control them manually.

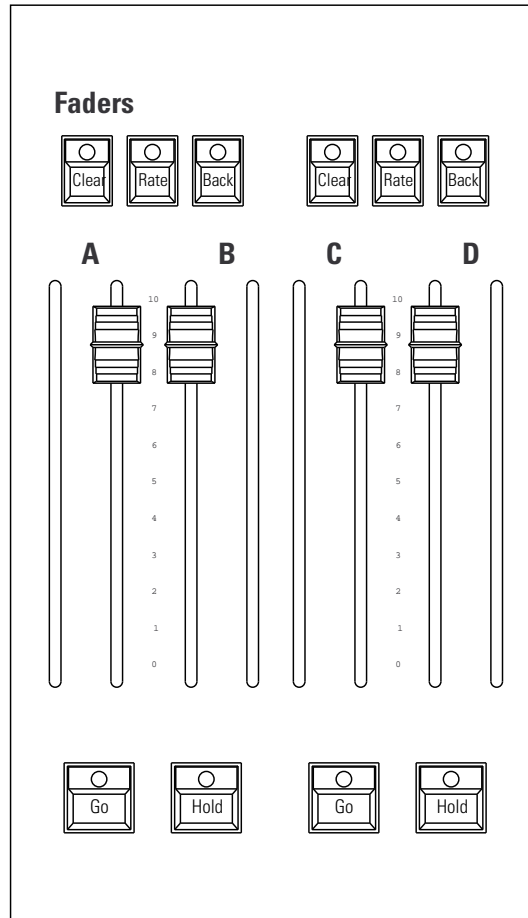

This chapter includes the following sections:

- Selecting cues
- Timed faders and LED displays
- Playback Cue List
- Fader Status display
- Selecting and playing cues
- Go to a different cue
- Controlling fades manually
- Quickstep

## ***Selecting cues***

There are three ways to determine which cue from the Cue List will play back on stage next:

- You can select a cue manually
- When a cue plays, Insight 2 automatically selects the next cue
- Insight 2 automatically selects linked cues

You must be in Stage mode to select cues to play back, but you can run the selected cue from either Stage or Blind by pressing [Go].

When one cue is playing, Insight 2 automatically selects the next cue on the Cue List to play next. To play the next cue, press the [Go] key under the fader in which you want the cue to be played. If you are working in Stage mode, you see the cue running on the monitor.

To select a cue other than the next on the Cue List, press [Cue], and enter the cue number. Then press [Go] to play the cue.

Cues that have been assigned a Follow time begin playing automatically once the cue before them on the Cue List finishes. When you play a string of follow cues you only need to start the first cue.

## Timed faders and LED displays

Insight 2 has two timed faders that allow you to play back recorded cues. In each fader, the left slider (A and C) controls upfades. The right sliders (B and D) control downfades. You may play back a cue automatically, using the timing information programmed into it, or you may take manual control.

You can play back cues one at a time through a single fader, or you can play back a different cue in each fader simultaneously. You can also play a cue in one fader, leave it there, and then play another cue in the second fader.

For example, you may want to play a ten-minute sunset cyc cue in one fader and play several cues during the same period in the other fader.

Each fader slider has a strip of LEDs next to it. When running a timed crossfade cue, the lit LEDs indicate the progress of the cue. This is displayed as a percentage. For example, when the LEDs are at **5**, 50 percent of the cue has run.

Insight 2's faders function in level override mode. This means that the fader sliders control the percentage of completion of the fade.

If you like, you can use the fader sliders to take manual control of fades. For information on taking manual control of fades, see the section titled *Controlling fades manually* later in this lesson.

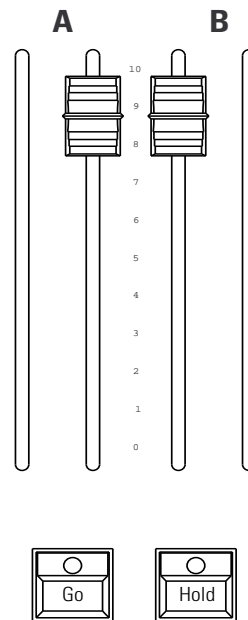

### Clearing faders

Each timed fader is equipped with a blue [Clear] key. To remove a cue from the fader, press the appropriate [Clear] key. Press [Clear] twice to clear an effect cue. Pressing [Clear] removes the cue from the fader immediately unless you have reset the default fader clear time. For instructions on changing fader clear time, see *Setting default fader clear time* on page 18.

## ***Cue List***

The Cue List provides a list of cues for the show, including all of the cues' programmed attributes. In addition, the display provides information about which cue is active or running and on which fader the cue is running.

The Cue List will display the playing cue or the last cue played and then the pending cue. **The pending cue is highlighted in white.**

### ***Cue indicators***

The color in which a cue is displayed provides information about the cue's current status.

**Gray** ..... Cue is not selected and is not in a fader.

**White** ..... Pending cue, will play back next time either [Go] button is pressed.

**Yellow** ..... Cue is in a fader, and is selected in Stage.

**Gold** ..... Cue is in a fader, but is not selected in Stage.

**Light red** ..... Cue is currently running and is selected in Stage.

**Dark red** ..... Cue is currently running, but is not selected in Stage.

**>** ..... Cue is selected in Stage or Blind.

## Fader Status display

The fader status display consists of two windows at the bottom of the display. It provides information about the cues loaded to the console's faders, including fade times and rates. The left window monitors the A/B fader, the right window monitors the C/D fader. The display counts down wait times for cues and indicates which step is running when an effect is active.

The illustration below shows where each piece of information appears.

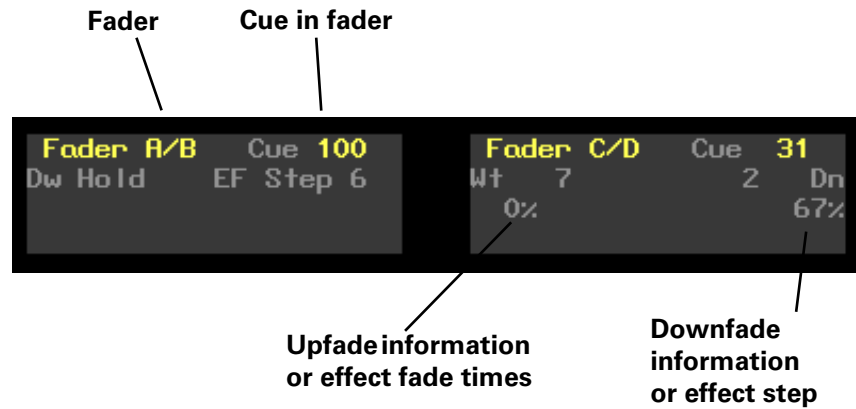

## Selecting and playing a cue

Selecting a cue moves it to the top of the Cue List. It will not run until you press [Go]. Follow these steps to select a cue and play it on the fader of your choice.

### Keystrokes:

1. Press [Stage].
2. Press [Cue].
3. Press [1][.][5].
4. Press [Enter].
5. Press [Go] on fader A/B.
6. Press [Go] on fader C/D.

### Action:

Selects Stage display mode

Prompt reads:

**Select cue number**

**To select cue type, press TYPE**

Selects cue 1.5 to play

Cue List moves cue 1.5 to the top of the list

Cue 1.5 runs on fader A/B; Cue 2 moves to the top of the Cue List

Cue 2 starts to run on fader C/D

## Go

Each fader has its own [Go] key. Press [Go] to play back the cue selected on the Cue List.

If you have pressed [Hold] to interrupt the playback of a cue, press [Go] to resume the fade.

If you press [Go] before a cue finishes playing, the previous cue stops, and the new cue begins from the levels at which the previous cue was interrupted.

## Hold

Each fader has its own [Hold] key. If a cue is running, press [Hold] to pause playback of the cue. Press [Hold] a second time to cancel playback of the cue in the fader, leaving it in the fader where it stopped, or press [Go] to resume the fade.

## **Back**

Each fader has its own [Back] key. Press [Back] to replay the cue most recently played on that fader. Press [Back] again to play the cue before it on the Cue List, and so forth, moving backward through the Cue List. Cues play back using the fade and wait times recorded with the cue.

*Note: The cue following the cue replayed by [Back] becomes the first cue in the Cue List. If you then press [Go], that cue plays.*

*Note: [Back] ignores cue links.*

This example demonstrates the use of the [Go], [Hold] and [Back] keys:

| <b>Keystrokes:</b>                     | <b>Action:</b>                 |
|--|--------------------------------|
| 1. Press [Stage].                      | Selects Stage mode display     |
| 2. Press [Cue] [2].                    | Selects Cue 2                  |
| 3. Press [Go].                         | Runs cue 2                     |
| 4. While cue is running, press [Hold]. | Running cue pauses             |
| 5. Press [Go].                         | Cue resumes                    |
| 6. Once cue finishes, press [Back].    | Previous cue fades up on stage |

## **Go to a different cue**

To play back a cue other than the cue highlighted on the Cue List, follow these steps:

| <b>Keystrokes:</b>  | <b>Action:</b>             |
|---------------------|----------------------------|
| 1. Press [Stage].   | Selects Stage mode display |
| 2. Press [Cue] [2]. | Selects cue 2              |
| 3. Press [Go].      | Runs cue 2                 |

# Controlling fades manually

Insight 2 provides two ways to take manual control of cue playback; manual override and rate override.

## Manual override

Manual override allows you to use the fader sliders to take manual control of fade levels. When you take manual control of cue playback, moving the fader slider controls the fade.

Leave the fader sliders at **10** before pressing [Go] to play cues back as recorded.

When you move the fader sliders below **10**, the cue runs until it reaches the slider setting. You can set the slider before you play the cue, or move the slider after the fade starts. The fade stops when it reaches the slider's level, and the slider then controls the fade. For example, if you set the sliders at **8**, the cue will play until it reaches 80 percent of its recorded levels, then give you manual control.

Set the sliders at **0** before you press [Go] to take manual control of fade from the beginning of cue.

*Hint: If you start a cue, and the performers skip ahead to the next cue, you have two options for speeding up to the next cue. If you do not need the current cue to reach its full intensity level settings, press [Go] to interrupt the current cue and begin the next one. However, if you need the current cue to reach its full level settings, push the sliders down to the lit LEDs and then back up to **10** immediately. Then press [Go] to start the next cue.*

Once the fade is complete, the cue is no longer controlled by the fader.

## ***Rate override***

Manual override allows you to control both the fade's rate and percentage of completion. When you play back a cue using rate override, the console controls the percentage of completion, but you control the rate.

Rate override allows you to play back a cue faster or slower than the rate at which it was recorded. The rate wheel adjusts the fade rate.

Fade rate is expressed as a percentage. A cue with a fade rate of 100 percent plays back at its recorded fade time. A fade rate of 300 plays the cue back three times faster than its recorded fade time. A fade rate of 50 plays the cue back half as fast as its recorded fade time. For example, if you record a cue with a 10 second fade time, a rate of 200 causes it to play back in five seconds. A fade rate of 50 causes it to play back in 20 seconds.

You may take control of a cue's fade rate while the cue is running. In addition, you may press both [Rate] keys to control rate of both faders.

Follow this example to place a cue in a fader under rate override:

### **Keystrokes:**

1. Press [Rate] key for the fader in which the cue is running. (Press both [Rate] keys if you wish to control both faders.)
2. Move rate wheel.

### **Action:**

Activates rate control

Fades are placed under control of the rate wheel. Move the wheel to adjust fade rates. Fader Status window shows the current rate

# Quickstep

Quickstep allows you to run through a show, checking all cues, without having to wait for fades. When Quickstep is active, the faders ignore all upfade, downfade, follow, and wait times. Cues snap immediately to their completed levels when you press [Go] or [Back].

To enable Quickstep and run a cue check, follow these steps:

| <b>Keystrokes:</b>   | <b>Action:</b>                                   |
|--|--|
| 1. Press [Stage].  | Selects Stage display                            |
| 2. Press [S7], <b>More Soft-keys</b> , [S1], <b>Enable Quickstep</b> . | Turns on Quickstep                               |
| 3. Press [Cue] [1] [Enter].  | Selects cue 1                                    |
| 4. Press [Go].   | Cue 1 comes up on stage instantly                |
| 5. Continue to press [Go] until you have checked all cues.             | Each cue comes up on stage instantly             |
| 6. Once you are finished, press [S1], <b>Disable Quickstep</b> .       | Turns off Quickstep; fades will operate normally |

# chapter 10

## groups

Insight 2 allows you to record frequently used combinations of channels into units called groups. You may record up to 500 groups.

Once you record a group, it can be combined with other channels and groups to create cues, submasters effects, or other groups. The principal difference between a group and a cue is that a group cannot be played back through a fader or slider. Consequently, it has no fade times, wait times or other playback attributes.

Group numbers are independent of cue numbers and may be numbered from 1 to 999.

This chapter includes the following sections

- Creating groups
- Displaying groups on stage
- Working with groups in Blind
- Modifying groups
- Labeling groups
- Deleting groups
- Copying groups
- Using cues or submasters as groups
- Using groups to modify cues, groups or submasters
- Only
- Group List

## ***Creating groups***

You can create groups in Stage, Blind and Fader modes.

To create a group, follow these steps:

| <b>Keystrokes:</b>  | <b>Action:</b>  |
|---|---|
| 1. Press [Stage].   | Selects Live display mode   |
| 2. Press [1] [Thru] [5] [Full] [6] [Thru] [9] [At] [5] [Enter]. | Selects channels 1 through 9 and sets them at proportional levels                                       |
| 3. Press [Record] [Group].                                      | Prompt reads:<br><b>To record group, select number and press ENTER</b><br><b>To cancel, press CLEAR</b> |
| 4. Press [1].   | Enters the group number you want to record<br>Corner reads: <b>Group 1</b>                              |
| 5. Press [Enter].   | Records group 1   |

## ***Creating a group from the look on stage***

To create a group from the look that's already on stage, follow these steps:

| <b>Keystrokes:</b>         | <b>Action:</b>  |
|----------------------------|---|
| 1. Press [Stage].          | Selects Stage display mode  |
| 2. Press [Record] [Group]. | Prompt reads:<br><b>To record group, select number and press ENTER</b><br><b>To cancel, press CLEAR</b> |
| 3. Press [2].              | Enters the group number you want to record<br>Corner reads: <b>Group 2</b>                              |
| 4. Press [Enter].          | Records group 2   |

## Creating a group using Solo

To create a group using some of the channels on stage, but not all, record the group using Solo. To do this, select the channels to add to the group, then press [Solo].

Follow these steps to create a group containing channels 5 through 20 when channels 1 through 25 are active on stage:

| <b>Keystrokes:</b>                 | <b>Action:</b>  |
|------------------------------------|---|
| 1. Press [Stage].                  | Selects Stage display mode  |
| 2. Press [1] [Thru] [2][5] [Full]. | Sets channels 1 through 25 to full on stage   |
| 3. Enter [5] [Thru] [2][0].        | Selects channels 5 through 20. All other channels remain unselected<br>Prompt reads:<br><b>Select excepted channel number</b>             |
| 4. Press [Solo].                   | All channels other than those selected drop to zero<br>Prompt reads:<br><b>(To restore levels, press SOLO)<br/>Select channel numbers</b> |
| 5. Press [Record] [Group].         | Prompt reads:<br><b>To record group, select number and press ENTER<br/>To cancel, press CLEAR</b>   |
| 6. Press [3].                      | Enters the group number you want to record<br>Corner reads: <b>Group 3</b>  |
| 7. Press [Enter].                  | Records selected channels into group 3  |
| 8. Press [Solo].                   | Restores full look to stage   |

*Hint: Press [Except] [Sub] [1] in step 2 to deselect channels contributed by submaster 1.*

## ***Displaying groups on stage***

To view a recorded group on stage, follow these steps:

| <b>Keystrokes:</b>   | <b>Action:</b>  |
|--|---|
| 1. Press [Stage].  | Selects Stage display mode  |
| 2. Press [Group] [2].  | Selects group 2<br>Prompt reads:<br><b>Group mode – Select group number to use as group</b>                               |
| 3. Press [Full].   | Prompt reads:<br><b>Group mode – Press AT or use wheel or trackpad to alter levels, or select channel numbers to edit</b> |
| 4. Adjust channel levels, as desired. Press [Rel] to release the group's channels. |   |

# Working with groups in Blind

There are two group modes in Blind, Group mode and Group Editing mode. In Group mode, Insight 2 brings up the channels from a group of your choice and allows you to use them to modify cues, submasters and other groups. In Group Editing mode, Insight 2 brings up the selected group itself and allows you to modify it.

## Group mode

To enter Group mode and bring up a group's channels, follow these steps:

| Keystrokes:                          | Action:  |
|--------------------------------------|--|
| 1. Press [Blind].                    | Selects Blind display mode   |
| 2. Press [Group] [1].                | Selects group 1's channels<br>Prompt reads:<br><b>Group mode – To recall a group, select the number and set it to a level</b><br><b>To create or modify a group, select the number and press ENTER</b> |
| 3. Press [At] [7][5].                | Sets the channels to 75 percent of their recorded levels<br>Prompt reads: <b>Group mode – Press AT or use wheel to alter levels, or select channel numbers to edit</b>                                 |
| 4. Press [Record] [Cue] [3] [Enter]. | Records the current level settings as cue 3  |

## Group Editing mode

To enter Group Editing mode and modify a recorded group, follow these steps:

| Keystrokes:                                   | Action:  |
|---|--|
| 1. Press [Blind].                             | Selects Blind display mode   |
| 2. Press [Group] [1].                         | Selects group 1's channels<br>Prompt reads:<br><b>Group mode – To recall a group, select the number and set it to a level</b><br><b>To create or modify a group, select the number and press ENTER</b> |
| 3. Press [Enter].                             | Selects group 1. Group status bar appears above softkeys. Channel levels are white<br>Prompt reads:<br><b>Select channel numbers</b>   |
| 4. Add, delete or modify channels as desired. |  |
| 5. Press [Record] [Enter].                    | Records the modified group 1   |

*Note: Once you are in Group Editing mode, use [S1], **Select Group**, rather than [Group], to bring up a different group. Use [Group] to access another group's levels as you modify the selected group.*

# Modifying groups

Insight 2 allows you to modify groups in Stage or Blind modes.

## In Blind

Follow these steps to add channels to a group in Blind display mode:

| Keystrokes:   | Action:   |
|---|---|
| 1. Press [Blind].   | Selects Blind display mode  |
| 2. Press [Group].   | Prompt reads:<br><b>Group mode – To recall a group, select the number and set it to a level</b>                           |
| 3. Press [1].   | Selects group 1's channels<br>Corner reads: <b>Group 1</b>  |
| 4. Press [Enter].   | Brings up group 1 in group editing mode. Channel levels should be white<br>Prompt reads:<br><b>Select channel numbers</b> |
| <i>Warning: You must press [Enter] after you enter the group number. If you do not, Insight 2 displays the channels used in the group, but does not enter Group Editing mode.</i> |   |
| 5. Press [2][5] [Thru] [3][0] [At] [5][0].  | Modifies look, adding channels 25 through 30 at 50 percent  |
| 6. Press [Record].  | Prompt reads:<br><b>To record group, select number and press ENTER</b><br><b>To cancel, press CLEAR</b>                   |
| 7. Press [Enter].   | Records group 1 with new levels   |

*Note: This process can also be used to create a new group in Blind display mode. If the group number you enter to modify doesn't exist, it is created as a new group.*

## ***In Stage***

Follow these steps to change a group's channel levels in Stage display mode:

| <b>Keystrokes:</b>   | <b>Action:</b>  |
|--|---|
| 1. Press [Stage].  | Selects Stage display mode  |
| 2. Press [Group] [2].  | Selects the group number you want to modify<br>Prompt reads:<br><b>Group mode – Select group number to use as group</b> |
| 3. Press [Full].   | Prompt reads:<br><b>Group mode – Press AT or use wheel to alter levels, or select channel numbers to edit</b>           |
| 4. Select channels you want to modify and adjust channel levels. | Alters look   |
| 5. Press [Record] [Group].                                       | Prompt reads:<br><b>To record group, select number and press ENTER</b><br><b>To cancel, press CLEAR</b>                 |
| 6. Press [2].  | Enters the group number you are modifying<br>Corner reads:<br><b>Group 2</b>  |
| 7. Press [Enter].  | Re-records group 2 with modified levels   |

## ***Using Update to modify groups***

The Update feature allows you to easily record changed levels on Stage into a selected group. You may record all levels on Stage into the group, or you may record only changes to channels that were previously recorded in the group. You may also add specific new channels to the group at their current Stage levels, to add all channels on Stage to the group at their current levels.

## ***Using Update to add new channels to a group***

You may use Update to add new channels to an existing group. To do so, you must specify the channels you wish to add. Follow these steps to use Update to add channels:

| <b>Keystrokes:</b>   | <b>Actions:</b>  |
|--|--|
| 1. Press [Stage].  | Selects Stage display mode   |
| 2. Select channels to add to the group and set their levels.           | Alters look  |
| 3. Press [S2], <b>Update</b> , [Group].                                | Prompt reads:<br><b>To update group, select number and press ENTER</b><br><b>(Press ONLY + ENTER to update only those channels already in group)</b> |
| 4. Press [2].  | Selects group 2 to update<br>Corner reads: <b>Group 2</b>  |
| 5. Press [Channel].  | Prompt reads:<br><b>To update channel(s), select number(s) and press ENTER</b><br><b>To cancel, press CLEAR</b>                                      |
| 6. Specify the channels to add. In this case, press [5] [Thru] [1][0]. | Corner reads: <b>Chan 10</b>   |
| 7. Press [Enter].  | Updates group 2 to include channels 5 through 10   |

## ***Using Update to change levels in a group***

Follow these steps to use Update to modify channels in a group:

| <b>Keystrokes:</b>  | <b>Actions:</b>  |
|---|--|
| 1. Press [Stage].   | Selects Stage display mode   |
| 2. Press [Group] [5].   | Selects group 5<br>Prompt reads:<br><b>Group mode – Select group number to use as group</b>  |
| 3. Press [Full].  | Brings group 5's channels up on stage<br>Prompt reads:<br><b>Group mode – Press AT or use wheel to alter levels, or select channel numbers to edit</b> |
| 4. Change the levels for the channels you want to modify in the group. This process will <b>not</b> add new channels. | Selects channels and sets levels   |
| 5. Press [S2], <b>Update</b> [Group].   | Prompt reads:<br><b>To update group, select number and press ENTER (Press ONLY + ENTER to update only those channels already in group)</b>             |
| 6. To update only channels already recorded in the group, press [Only].   | Limits update to channels already in group   |
| 7. Press [5] [Enter].   | Updates channel levels in group 5  |

## Labeling groups

Insight 2 allows you to use an alphanumeric keyboard to assign labels to groups. See page 282 for more information about selecting and installing a keyboard. Group labels can consist of any combination of letters, numbers and symbols, and may be up to 16 characters long.

Follow these steps to add a label to a group:

| <b>Keystrokes:</b>   | <b>Action:</b>   |
|--|--|
| 1. Press [Blind].  | Selects Blind display mode   |
| 2. Press [Group] [1].  | Prompt reads:<br><b>Group mode – To recall a group, select the number and set it to a level</b><br><b>To create or modify a group, select the number and press ENTER</b> |
| 3. Press [Enter].  | Prompt reads:<br><b>Select channel numbers</b>   |
| 4. Press [Label].  | Prompt reads:<br><b>Type group label</b><br><b>(F6 = clear to end,</b><br><b>F7 = last group label,</b><br><b>F8 = next group label)</b>                                 |
| 5. Use the alphanumeric keyboard to enter a label. Type "Scene 1 Cyc." | Corner reads:<br><b>Label Scene 1 Cyc</b>  |
| 6. On the Insight 2 keypad, press [Enter].                             | Group 1 is labeled   |

*Note: Press [F7] or [F8] on the alphanumeric keyboard to select the previous group or the next group to label.*

## Deleting groups

You must be in Stage mode to delete individual groups. To delete all groups, you can use the Clear Groups option from the Clear Functions menu, as described in *Chapter 18, Clear Functions*, on page 197.

To delete individual groups, follow these steps:

| <b>Keystrokes:</b>  | <b>Actions:</b>   |
|---|---|
| 1. Press [Stage]  | Selects Stage display   |
| 2. Press [S7], <b>More Soft-keys</b> , [S6], <b>Delete</b> , [Group]. | Prompt reads:<br><b>To delete group, press ENTER</b><br><b>To cancel, press CLEAR</b> |
| 3. Press [2].   | Enters group number to delete<br>Corner reads: <b>Group 2</b>                         |
| 4. Press [Enter].   | Prompt reads:<br><b>To confirm, press ENTER</b><br><b>To cancel, press CLEAR</b>      |
| 5. Press [Enter] to delete the group or [Clear] to cancel the action. | Group 2 is deleted from your show   |

## Copying groups

You may make a copy of a group, then use the copy as the foundation for a new group. You can copy groups in Stage or Blind modes. To copy a look from one group to another, follow these steps:

| <b>Keystrokes:</b>                                      | <b>Actions:</b>   |
|---|---|
| 1. Press [Blind] or [Stage].                            | Selects display mode  |
| 2. Press [Group].                                       | Prompt reads:<br><b>Group mode – Select group number to use as group</b>                                      |
| 3. Press [1].   | Enters the number of the group you wish to copy<br>Corner reads: <b>Group 1</b>                               |
| 4. Press [Full].  | Prompt reads:<br><b>Group mode – Press AT or use wheel to alter levels, or select channel numbers to edit</b> |
| 5. Once the group is displayed, press [Record] [Group]. | Prompt reads:<br><b>To record group, select number and press ENTER</b><br><b>To cancel, press CLEAR</b>       |
| 6. Press [5].   | Enters the number of the new group<br>Corner reads: <b>Group 5</b>  |
| 7. Press [Enter].                                       | Group copy is complete. You can now modify the new group  |

*Note: You may also copy a group's channels and levels to a cue or a sub-master. To do so, press [Cue] or [Sub] in place of [Group] in step 5.*

## Using cues or submasters as groups

If you wish, you can treat the channels recorded in a cue or a submaster as if they were a group, bringing them up on stage or including them in other level setting operations.

For example, to bring up a cue on stage as a group, follow these steps:

| <b>Keystrokes:</b>  | <b>Actions:</b>  |
|---|--|
| 1. Press [Stage].   | Selects Stage display mode   |
| 2. Press [Group].   | Tells Insight 2 to treat the next entry as a group<br>Prompt reads:<br><b>Group mode – Select group number to use as group</b>   |
| 3. Press [Cue] and enter the number of the cue you want to bring up.                        | Prompt reads:<br><b>Group mode – Select cue number to use as group</b>   |
| 4. Press [At] and enter the level at which you wish to bring the cue up. (Or press [Full].) | The cue's channels are brought up on stage at the specified level<br>Prompt reads:<br><b>Group mode – Press AT or use wheel to alter levels, or select channel numbers to edit</b> |

To use a submaster as a group, follow the same procedure, but press [Sub] instead of [Cue] in step 3.

*Note: You may not group the channels in a cue part, only in a whole cue.*

*Note: You may not group the channels in an effect cue or effect submaster.*

## ***Using groups to modify cues or submasters in Blind***

You can use groups to modify cues or submasters. For example, let's say you have created a group 3 that contains channels 1 through 10 at a level of 75 percent. Follow these steps to add group 3 to submaster 2:

| <b>Keystrokes:</b>   | <b>Action:</b>   |
|--|--|
| 1. Press [Blind].  | Selects Blind display mode   |
| 2. Press [Sub] [2].  | Prompt reads:<br><b>Select submaster number</b><br><b>To select submaster type, press TYPE</b>   |
| 3. Press [Group] [3].  | Selects group 3's channels<br>Prompt reads: <b>Group mode –</b><br><b>To recall a group, select the number and set to a level</b><br><b>To create or modify a group, select the number and press ENTER</b> |
| 4. Set channel levels. (Or, press [Enter] to impose only the group's proportions on the currently set levels.) | Prompt reads:<br><b>Group mode – Press AT or use wheel or trackpad to alter levels, or select channel numbers to edit</b>  |
| 5. Press [Record].   | Prompt reads:<br><b>To record submaster, select number and press ENTER</b><br><b>To cancel, press clear</b>  |
| 6. Press [Enter] to re-record the modified submaster.  | Records submaster 2 with group 3's channels added  |

Submaster 2 now contains channels 1 through 10 at 75 percent, in addition to whatever other channels are already part of it. If any of the channels between 1 and 10 were already included, their levels were modified to match those in the group.

The same procedure can be used to combine groups and cues. Groups can also be used as elements in effects. Anywhere you set channel levels, you can use a group to select those channels and set their levels.

# Only

Only allows you to select several groups and then adjust only the channels the groups have in common. For example, say you are working with moving lights. Each fixture is controlled by a number of channels, each of which controls a single parameter (level, tilt (vertical movement), pan (horizontal movement), colors, and so forth). You create groups that contain all the control channels for each light, as shown below.

In the example below, each group contains six channels, corresponding to pan, tilt, intensity, cyan, magenta, and yellow for a specific fixture.

Group 1 contains all channels for fixture 1  
01 02 03 04 05 06

Group 2 contains all channels for fixture 2  
11 12 13 14 15 16

Group 3 contains all channels for fixture 3  
21 22 23 24 25 26

Group 4 contains all channels for fixture 4  
31 32 33 34 35 36

Next you create a set of groups that each contain all the channels that control one parameter for your moving lights.

Group 5 contains all pan-controlling channels  
01 11 21 31

Group 6 contains all tilt-controlling channels  
02 12 22 32

Group 7 contains all level-controlling channels  
03 13 23 33

Now, say you wish to change the level for fixtures 1 and 3. The following keystrokes would select only the appropriate channels.

[Group] [1] [And] [3] [Only] [Group] [7]

This selects groups 1 and 3, which correspond to fixtures 1 and 3, then selects only the channels in those groups which are also in Group 7, the level group (3 and 23). You may now press [At] [7][5] to set the levels of the two fixtures at 75 percent.

# Group List

Press [Blind] [Group] [Enter] [S2], **Group List**, to display the Group List.

The Group List displays the group number and label of all recorded groups. Up to 38 groups may be displayed at a time. Use [S4], **Previous Page**, and [S5], **Next Page**, to move forward and backward from page to page or use [+] and [-] to scroll through the groups. The selected group is displayed in white and the selected field is highlighted in yellow; other groups are displayed in gray.

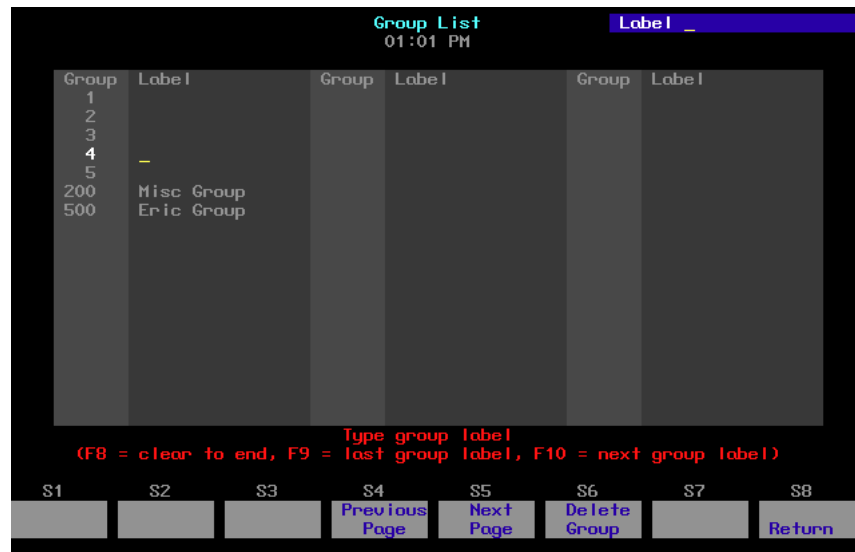



# chapter 1 1

## submasters

Insight 2 provides you with 108 submasters. A submaster is a group of channels recorded at proportional levels and controlled by a slider and a bump button. Submasters enable you to save complex looks you use frequently and play them back manually. They can also be used as building blocks when you create scenes, cues or other submasters.

A channel may be included in any number of submasters. You can record a total of 1,080 submasters. (108 submasters in each of ten pages of submaster memory.)

Each submaster consists of a slider and a bump button with one or two LEDs. The slider allows you to bring the submaster look up manually. The bump button allows you to flash the submaster to its full recorded level, or to begin its programmed fade, if it has one. The green LEDs show you which sliders contain recorded submasters. The red LEDs in the bottom row indicate whether the submasters are pile-on (green) or inhibitive (red).

This chapter includes the following sections:

- Submaster types
- Submaster pages
- Playback Submaster List
- Submaster LEDs
- Submaster bump buttons
- Recording submasters
- Creating inhibitive submasters
- Modifying submasters in Blind
- Modifying submasters in Stage
- Using Update to modify submasters
- Live control of a submaster
- Controlling submaster fades manually
- Labeling submasters
- Copying submasters
- Loading cues or groups to submasters
- Copying cues or groups to submasters
- Clearing submasters
- Submaster List

## **Submaster types**

Submasters can be pile-on, inhibitive or effect.

### ***Pile-on submaster***

A pile-on submaster consists of channels recorded at proportional levels. If a pile-on submaster's channel levels are higher than established channel levels, the submaster's levels take precedence (except as noted below). If they are lower, the established levels take precedence. If a submaster slider contains a recorded pile-on submaster, the green LED lights.

*Note: Channel levels set on the keypad and inhibitive submasters both override pile-on submaster levels.*

### ***Inhibitive submaster***

An inhibitive submaster holds the output of channels below a specified level. An inhibitive submaster doesn't actually set channel levels, it just prevents them from exceeding a specified level. Only submasters 73 through 108 may be inhibitive. If a submaster slider contains a recorded inhibitive submaster, the red LED lights.

### ***Effect submaster***

An effect submaster has an effect recorded in it. Press an effect submaster's bump button or move its slider to start the effect running. See *Chapter 12, Working with effects*, for more information on effect submasters. Any submaster may be programmed with an effect. If a submaster slider contains a recorded effect submaster, the green LED lights.

## Changing type

You can change a submaster's type by using the [Type] key. When you change a submaster type, levels recorded in the submaster are retained. This means that you can change a submaster from pile-on to inhibitive and back without losing any level or timing information. If you change the type to effect, channel and level information is erased.

To change a submaster's type, follow these steps:

| <b>Keystrokes:</b>                       | <b>Action:</b>  |
|--|---|
| 1. Press [Blind].                        | Selects Blind display   |
| 2. Press [Sub] [#].                      | Prompt reads:<br><b>Select submaster number</b>   |
| 3. Press [Type].                         | Prompt reads:<br><b>Select submaster type</b><br><b>(1 = Pile-on, 2 = Inhibitive, 3 = Effect)</b> |
| 4. Press [1], [2] or [3] to select type. | New type is entered in submaster status bar   |

Type changes do not take effect while the submaster is active. An active submaster's bump button LED blinks after you change its type. To deactivate it, move its slider to zero if the green LED blinks, or to **10** if the red LED blinks.

The LED then blinks to indicate the new type. Again, move its slider to zero if the green LED blinks or to **10** if the red LED blinks. See *Submaster LEDs* on page 127 for more information about the LED.

## Submaster pages

Insight 2 provides ten pages of submasters. A page is a block of console memory that contains one set of 108 recorded submasters, corresponding to the 108 submaster sliders. The ten pages of memory increases the number of possible submasters to 1,080.

Insight 2 displays the message **Sub page 1 (2, 3...)** in the upper left corner of the display to indicate the current submaster page. To switch from one page to the other, press [Page], enter the desired page number, and press [Enter].

When you switch submaster pages, any submasters on stage remain on stage until you move their sliders to the home position. Until the new submaster loads, submaster LEDs flash slowly, indicating that the submaster on stage is from the previously loaded page. If flashing red, the new submaster is inhibitive; if green, the new submaster is pile-on. When you move the slider to its home position the new submaster is loaded and the LED stops flashing. This prevents the stage from going black or changing levels when you switch pages. (Fast flashes designate a submaster with a dwell time of **Hold**. See *Submaster LEDs* on page 127 for more information about LEDs.)

*Note: When you read a new show into the console from a disk, the console loads the same page number that was loaded from the previous show. Any submasters on stage when you read a new show into the console remain on stage until you move their sliders to the home position. Until the new submaster loads, submaster LEDs flash, indicating that the submaster on stage is from the previously loaded show. If flashing red, the new submaster is inhibitive; if green, the new submaster is pile-on. When you move the slider to its home position the new submaster is loaded and the LED stops flashing.*

## Submaster LEDs

Each submaster bump button contains one or two LEDs. The color and state of the LED indicates the current state of that submaster, as shown on the chart below:

| <b>Color</b> | <b>State</b> | <b>Meaning</b>   |
|--------------|--------------|--|
| —            | Off          | Submaster not loaded.  |
| Green        | Solid        | Submaster (pile-on or effect) loaded.  |
| Green        | Slow Blink   | New pile-on or effect submaster. Loads when slider reaches home position.          |
| Green        | Fast Blink   | Submaster (pile-on or effect) on timed hold. Press bump button to begin downfade.  |
| Red          | Solid        | Inhibitive submaster loaded.   |
| Red          | Slow Blink   | New submaster is an inhibitive submaster. Loads when slider reaches home position. |
| Red          | Fast Blink   | Inhibitive submaster on timed hold. Press bump button to begin downfade.           |
| Red & Green  | Both on      | Submaster slider serves as master for DMX In.                                      |

If the LED on a slider is blinking slowly, it means that you have changed pages and a new submaster is waiting to load. The old submaster stays loaded until you move the slider to the home position. If the green LED is blinking, move the slider to zero. If the red LED is blinking, move the slider to 10. If the submasters are changing type, you may need to do both. When the slider reaches home, the channel levels from the new page replace the old levels.

*Note: If a submaster slider has both a submaster loading and a submaster on hold, the submaster on hold takes priority and the LED blinks fast. Press the bump button to downfade the old submaster.*

## ***Submaster bump buttons***

A bump button is located immediately below each submaster slider. The bump button's function depends on its status (see below) and on whether the submaster has a programmed fade.

If the submaster does not have a programmed fade, the bump button allows you to bring up the submaster's contents on stage instantly. Press the bump button to raise the submaster to its full recorded level. Hold the button to maintain the levels on stage. Release the button to remove the submaster's levels.

If the submaster has a programmed fade, the bump button allows you to start the fade, or to reverse the direction of an ongoing fade. Press the bump button to start the upfade. Press the button again to interrupt the upfade and start the downfade.

### ***Bump button status***

Submaster bump buttons may be individually enabled, disabled or placed in Solo mode. An enabled bump button functions normally, a disabled button doesn't function at all, and a button in Solo mode brings its channels to their recorded level and reduces all other channels to zero.

If a submaster's bump button is disabled or in Solo mode a **D** or an **S** appear next to the submaster's number on the Submaster List and the Status Bar.

To set a bump button's status, follow these steps:

| <b>Keystrokes:</b>                  | <b>Action:</b>  |
|-------------------------------------|---|
| 1. Press [Blind].                   | Selects Stage display mode  |
| 2. Press [Sub] [5].                 | Selects submaster 5   |
| 3. Press [S1], <b>Bump Status</b> . | Prompt reads: <b>Select bump status and press ENTER</b><br><b>(1 = enabled, 2 = disabled, 3 = solo)</b> |
| 4. Press [2].                       | Selects <b>disabled</b> . The keypad corner indicates the choice you have made                          |
| 5. Press [Enter].                   | Submaster 5's bump button is disabled   |

## ***Bump button mode***

Submaster bump buttons may be set in Channel or Submaster modes. In either mode, you have the option of putting them in Solo mode. The following sections describe each mode.

### ***Submaster mode***

Press the [Sub Mode] key to switch the submaster bump buttons into Submaster mode. The submasters recorded in the console's submaster memories are loaded into the submaster sliders. Each submaster slider and bump button now controls its assigned submaster.

### ***Channel mode***

Press the [Sub Mode] key again to switch the submaster bump buttons into Channel mode. In channel mode, each submaster slider and bump button controls the correspondingly numbered channel, i.e., slider 1 controls channel 1, slider 2 controls channel 2 and so forth.

### ***Solo mode***

Press [Solo Bump] to put the submaster bump buttons into Solo mode. The LED inset into the key lights to indicate that Solo mode is active. In Solo mode, pressing any submaster bump button brings its channels to their recorded level (or brings its channel to Full if in Channel mode) and takes all other channels to zero.

## Recording submasters

You can create submasters in Live or Blind mode. Follow these steps to record a simple, pile-on submaster:

| Keystrokes:  | Action:   |
|--|---|
| 1. Press [Stage].  | Selects Stage display mode  |
| 2. Select channels and set channel levels.                             | Creates look  |
| 3. Press [Record].   | Prompt reads:<br><b>To record cue, select number and press ENTER</b><br><b>To cancel, press CLEAR</b> |
| 4. Press [Sub] [5] [Enter]<br>or...<br>Press Submaster 5's bump button | The current stage look is recorded into submaster 5   |

*Note: Use Solo to record specific channels into the submaster (rather than the full stage look). For example: [5] [Thru] [1][0] [Solo] [Record] [Sub] [5] [Enter] records only the current levels of channels 5 through 10 in submaster 5, regardless of what other channel levels may be up on stage.*

## Fade and dwell times for submasters

Normally, pressing a sub bump brings channel levels to their recorded level immediately. If you prefer, you can record submasters with fades. Insight 2 provides a submaster upfade time, downfade time and dwell time.

Upfade time is the length of time it takes a submaster's channels to fade to their recorded levels when the submaster bump button is pressed.

Dwell time is the length of time the submaster's channel levels stay at their full recorded levels before the downfade starts.

Downfade time is the length of time it takes a submaster's channels to fade from their recorded levels to zero.

When you record fade times for a submaster, you can play the recorded fade with the bump button or override it manually with the slider. See *Controlling submaster fades manually* on page 138 for more information.

*Note: Default fade time is 0/Man/0, meaning the submaster has a zero upfade, a manually controlled dwell time, and a zero downfade. Channels stay at full recorded levels as long as the bump button is held.*

Fade times may be expressed in minutes and seconds, or as fractions of seconds (in decimal format). Fade times can be programmed from .1 second to 99:59 minutes. Acceptable time values include: .2 (.2 seconds), 00:12 (12 seconds), 5.5 (5.5 seconds), or 5:30 (five minutes, 30 seconds).

## ***Adding fade and dwell times***

You can add fade and dwell times to a submaster from Stage or Blind mode. To add fade times to a submaster, follow these steps in either mode:

| <b>Keystrokes:</b>  | <b>Action:</b>  |
|---|---|
| 1. Press [Sub].   | Prompt reads:<br><b>Select submaster number</b><br><b>To select submaster type, press</b><br><b>TYPE</b>                    |
| 2. Press [5].   | Selects submaster 5<br>Corner reads:<br><b>Sub 5</b>  |
| 3. Press [Time].  | Prompt reads:<br><b>Enter upfade time</b>   |
| 4. Use keypad to enter upfade time and press [Time].  | Prompt reads:<br><b>Enter dwell time</b><br><b>(Press CLEAR for hold, press CLEAR</b><br><b>CLEAR for manual operation)</b> |
| 5. Use keypad to enter dwell time and press [Time].<br>(See next page for information about using a <b>Hold</b> dwell.) | Prompt reads:<br><b>Enter downfade time</b>   |
| 6. Use keypad to enter downfade time and press [Enter].   | New fade times are recorded into submaster 5  |

*Note: Once a timed submaster is running, press the bump button to change the direction of the fade. For example, if the upfade is half finished, pressing the bump button starts the downfade from 50 percent. If a downfade is running, pressing the bump button begins an upfade again from the current level.*

## ***Hold dwell time***

If you record a submaster with a dwell time of **Hold**, the submaster fades up when you press the bump button, then holds until you press it again.

To add a dwell time of **Hold** to a submaster, follow these steps:

| <b>Keystrokes:</b>        | <b>Action:</b>  |
|---------------------------|---|
| 1. Press [Sub].           | Prompt reads:<br><b>Select submaster number<br/>To select submaster type, press<br/>TYPE</b>                    |
| 2. Press [5].             | Selects submaster 5<br>Corner reads: <b>Sub 5</b>   |
| 3. Press [Time] [Time].   | Prompt reads:<br><b>Enter dwell time<br/>(Press CLEAR for hold, press CLEAR<br/>CLEAR for manual operation)</b> |
| 4. Press [Clear].         | Corner reads: <b>Dwell Hold</b>   |
| 5. Press [Enter] [Enter]. | Dwell time is set to <b>Hold</b> for<br>submaster 5   |

## ***Manual dwell time***

If you record a submaster with a dwell time of **manual** and an upfade time other than zero, the upfade starts when you press and hold the bump button. It runs until channels reach full recorded levels, then holds at full as long as you hold the bump button; the downfade begins when you release it. If you don't hold the bump button for the duration of the upfade time, channels do not reach their full recorded levels.

*Note: If you do not enter a dwell time for a submaster, the submaster defaults to a manual dwell.*

To convert a timed dwell to a manual dwell in Blind mode, follow these steps:

| <b>Keystrokes:</b>        | <b>Action:</b>  |
|---------------------------|---|
| 1. Press [Sub].           | Prompt reads:<br><b>Select submaster number<br/>To select submaster type, press<br/>TYPE</b>                    |
| 2. Press [5].             | Selects submaster 5<br>Corner reads: <b>Sub 5</b>   |
| 3. Press [Time] [Time].   | Prompt reads:<br><b>Enter dwell time<br/>(Press CLEAR for hold, press CLEAR<br/>CLEAR for manual operation)</b> |
| 4. Press [Clear] [Clear]. | Corner reads: <b>Dwell Man</b>  |
| 5. Press [Enter] [Enter]. | Dwell time is set to <b>Manual</b> for<br>submaster 5   |

## Adding a rate to a submaster

Rate allows you to record submasters that play back faster or slower than their recorded fade times. This can be especially helpful when you are trying to calculate complex timing information for effects loaded to a submaster.

*Note: If you adjust the rate on a submaster containing an effect, the rate adjustments affect individual step timing, but do not change the overall effect timing.*

Rate is expressed as a percentage. A submaster with a rate of 100 plays back at its recorded fade time. A rate of 300 plays the submaster back three times faster than its recorded fade time. A rate of 50 causes it to play back half as fast as its recorded fade time. You may assign a rate of up to 2,000 percent.

To add a rate to submaster 7, follow these steps:

| Action:                      | Keystrokes:  |
|------------------------------|--|
| 1. Press [Blind].            | Selects Blind display mode   |
| 2. Press [Sub] [7].          | Prompt reads:<br><b>Select submaster number</b><br><b>To select submaster type, press TYPE</b> |
| 3. Press [S3], <b>Rate</b> . | Prompt reads:<br><b>Use keypad to select submaster rate (0 to 2000, 100 = Normal)</b>          |
| 4. Press [1][5][0].          | Corner reads: <b>Rate 150</b>  |
| 5. Press [Enter].            | Rate of 150 percent is recorded into submaster 7   |

## Specifying a submaster's page

You may specify the page to which you record submasters. For example, if page 1 is loaded, you can record a submaster to page 2. To do so, follow these steps:

| Keystrokes:                         | Action:   |
|-------------------------------------|---|
| 1. Create a look in Stage.          |   |
| 2. Press [Record] [Sub].            | Prompt reads:<br><b>To record submaster, select number and press ENTER</b><br><b>To cancel, press CLEAR</b> |
| 3. Press [Page] [2].                | Prompt reads:<br><b>Select page on which to record submaster, then press submaster bump button</b>          |
| 4. Press submaster 6's bump button. | Current levels are recorded into submaster 6 on submaster page 2  |

## ***Using Except to record a submaster without another submaster's channels***

Insight 2 allows you to program a submaster containing all the current levels on stage except for those contributed by a specific cue, group, or another submaster.

This example illustrates how you record a submaster without including levels contributed by the specified submaster:

| <b>Keystrokes:</b>                                 | <b>Action:</b>   |
|--|--|
| 1. Press [Stage].                                  | Selects Stage display mode   |
| 2. Select desired channels and set channel levels. |  |
| 3. Press [Record] [Sub].                           | Prompt reads:<br><b>To record submaster, select number and press ENTER</b><br><b>To cancel, press CLEAR</b>        |
| 4. Press [5].                                      | Selects submaster 5 to be recorded   |
| 5. Press [Except] [Sub] [3].                       | Instructs that levels raised by submaster 3 be ignored<br>Prompt reads:<br><b>Select excepted submaster number</b> |
| 6. Press [Enter].                                  | Records submaster 5 minus submaster 3's levels   |

*Note: Press [Cue] or [Group] in place of [Sub] in step 5 to leave out the channels supplied by a cue or group.*

*Note: [Except] will not work with effect cues or effect submasters.*

## Creating inhibitive submasters

A red LED on the bump button indicates an inhibitive submaster. Only submasters 73 through 108 may be inhibitive.

Inhibitive submasters allow you to limit the output of a group of channels. Channel outputs are limited to the level at which you set the slider. An inhibitive submaster set at **10** (100 percent), does not affect channel output. An inhibitive submaster controls the levels of its assigned channels in the same way the Grandmaster controls the levels of all channels.

*Note: If channels that you expect to see on stage are missing or at the wrong levels, check to see if a submaster is inhibiting them. If a channel is fully inhibited by a submaster, its level will be displayed as a yellow zero.*

Follow these steps to create an inhibitive submaster:

| <b>Keystrokes:</b>  | <b>Actions:</b>  |
|---|--|
| 1. Press [Stage].   | Selects Stage display  |
| 2. Press [Sub] and enter the number of the submaster (73 to 108) you wish to be inhibitive. | Selects sub to change<br>Prompt reads:<br><b>Select submaster number</b><br><b>To select submaster type, press TYPE</b>      |
| 3. Press [Type].  | Prompt reads:<br><b>Select submaster type</b><br><b>(1 = Pile-on, 2 = Inhibitive</b><br><b>[Other types are Blind only])</b> |
| 4. Press [2]. LED flashes green, unless slider is at zero.                                  | Channel levels change to <b>IN</b> and the submaster number is red   |
| 5. Move slider to zero. LED flashes red.  | Pile-on levels are unloaded  |
| 6. Move slider to <b>10</b> .   | Inhibitive control is loaded   |

Follow the same procedure to convert back to pile-on.

- You may include the same channel in more than one inhibitive submaster.
- If you press an inhibitive submaster's bump button, the submaster fades from its current slider location to zero and back, using its recorded fade times.

## ***Modifying submasters in Blind***

To modify a submaster in Blind, follow these steps:

| <b>Keystrokes:</b>                                   | <b>Actions:</b>   |
|--|---|
| 1. Press [Blind].                                    | Selects Blind display   |
| 2. Press [Sub] [1].                                  | Prompt reads:<br><b>Select submaster number</b><br><b>To select submaster type, press TYPE</b>              |
| 3. Press [Enter].                                    | Brings up current level settings for submaster 1<br>Prompt reads:<br><b>Select channel numbers</b>          |
| 4. Enter channel numbers and set desired new levels. | Sets new levels   |
| 5. Press [Record].                                   | Prompt reads:<br><b>To record submaster, select number and press ENTER</b><br><b>To cancel, press CLEAR</b> |
| 6. Press [Enter].                                    | Changes to submaster 1 are recorded   |

## ***Modifying submasters in Stage***

To modify a submaster in Stage, follow these steps:

| <b>Keystrokes:</b>   | <b>Actions:</b>  |
|--|--|
| 1. Press [Stage].  | Selects Stage display  |
| 2. Use the submaster slider to raise submaster 2 to full on stage. | Submaster 2's channels rise on stage to recorded levels  |
| 3. Enter channel numbers and set desired new levels.               | New levels are set on stage  |
| 4. Press [Record], then press submaster 2's bump button.           | Submaster 2 is recorded with the new levels. Submaster LED blinks, indicating that submaster 2 has been changed and the changes have not been loaded |
| 5. Press [Rel].  | Releases newly set levels  |
| 6. Slide submaster slider to zero, then back to full.              | Loads submaster 2's new levels and brings them up on stage   |

## Using Update to modify submasters

The Update feature allows you to easily record changed levels on Stage into a selected submaster. You may record all levels on Stage into the submaster, or you may record only changes to channels that were previously recorded in the submaster.

*Note: When you use Update to modify a submaster, the updated submaster takes control of all stage levels for channels in the submaster.*

Follow these steps to update a submaster:

| <b>Keystrokes:</b>  | <b>Actions:</b>   |
|---|---|
| 1. Press [Stage].   | Selects Stage display mode  |
| 2. Set submaster 6's slider to <b>10</b> . <sup>†</sup>                       | Puts submaster 6's current look on stage  |
| 3. Select and set desired levels for channels to update in the submaster.     | Selects channels and sets levels  |
| 4. Press [S2], <b>Update</b> , [Sub].   | Prompt reads:<br><b>To update submaster(s), select number(s) and press ENTER (Press ONLY + ENTER to update only those channels already in submaster(s))</b> |
| 5. To update only the channels already recorded in submaster 6, press [Only]. | Limits update   |
| 6. Press submaster 6's bump button.   | Submaster 6 is updated  |

<sup>†</sup>*Note: If you do not set the slider to **10**, Insight 2 will update the submaster proportionally. This means that the outputs on stage will match their current level only when the slider is at its current position.*

*For example, if the slider is at 50 percent, channel 1 is on stage at 25 percent and you press [Update], channel 1 is set so that when the slider returns to **5**, channel 1 returns to 25 percent. This means that when the submaster is full, channel 1 is at 50 percent.*

*The console will not allow you to update a channel in a submaster to a level higher than the level to which the submaster slider is set.*

## ***Live control of a submaster's rate***

In Stage mode, selecting a submaster and pressing [S3], **Rate**, allows the timing of the submaster to be controlled by the rate wheel or keyboard entry.

Follow these steps to change the rate of an active submaster in Stage. (This procedure also works if the submaster is not active. In either case, the new rate is automatically recorded in the submaster.)

| <b>Keystrokes:</b>           | <b>Action:</b>  |
|------------------------------|---|
| 1. Press [Stage].            | Selects Live display  |
| 2. Press [Sub] [5].          | Selects submaster 5   |
| 3. Press [S3], <b>Rate</b> . | Activates rate control<br>Prompt reads:<br><b>Select submaster rate and press ENTER, or use wheel or trackpad to alter rate (0 to 2000, 100 = Normal)</b> |
| 4. Move Rate wheel.          | Sets and records fade rate for submaster 5. If submaster is running, fade proceeds at new rate  |

*Note: When the submaster rate is controlled by the rate wheel, the submaster's number turns blue on the Submaster List.*

## ***Controlling submaster fades manually***

When you press the bump button on a timed submaster, recorded fade times play back as you recorded them. Insight 2 allows you to use the slider to take manual control of submasters recorded with fade times.

The Submaster List shows the progress of the submaster's fade. To override the fade, push the submaster's slider to a higher level than the fade (lower, if inhibitive).

Once the slider passes the fade (or meets it at Full on pile-on submasters or zero on inhibitive submasters), control of the fade transfers to the slider and you have full manual control of the submaster. Move the slider to set the fade level.

## Labeling submasters

Insight 2 allows you to use an alphanumeric keyboard to label submasters. Submaster names can consist of any combination of letters, numbers and symbols, and may be up to 16 characters long. See page 282 for information about installing an alphanumeric keyboard.

Follow these steps to add the name “Bedroom wash” to submaster 4:

| Keystrokes:  | Action:  |
|--|--|
| 1. Press [Stage].  | Selects Stage display  |
| 2. Press [Sub] [4].  | Prompt reads:<br><b>Select submaster number<br/>To select submaster type, press<br/>TYPE</b> |
| 3. Press [Label].  | Prompt reads:<br><b>Type submaster name</b>  |
| 4. Use the alphanumeric keyboard to enter the label.<br>Type <b>Bedroom wash</b> . | Corner reads:<br><b>Label: Bedroom wash</b>  |
| 5. On the Insight 2 keypad, press [Enter].   | Submaster 4 is labeled <b>Bedroom wash</b>   |

## Copying submasters

To copy a look from one submaster to another, follow these steps:

| Keystrokes:  | Actions:  |
|--|---|
| 1. Press [Blind].                                      | Selects Blind display mode  |
| 2. Press [Sub].  | Prompt reads:<br><b>Select submaster number<br/>To select submaster type, press<br/>TYPE</b>              |
| 3. Enter the number of the submaster you wish to copy. | Corner reads:<br><b>Sub 1</b>   |
| 4. Press [Record] [Sub].                               | Prompt reads:<br><b>To record submaster, select number<br/>and press ENTER<br/>To cancel, press CLEAR</b> |
| 5. Enter the number of the new submaster.              | Corner reads:<br><b>Sub 9</b>   |
| 6. Press [Enter]. Submaster copy is complete.          | Contents of submaster 1 are copied to submaster 9   |

*Note: You may also copy a look from a submaster to a cue or a group. To do so, press [Cue] or [Group] in place of [Sub] in step 4.*

## ***Loading cues or groups to submasters***

[Load Sub] allows you to load the contents of one or more recorded groups or cues into submasters.

To load a look from a range of cues or groups to submasters, follow these steps:

| <b>Keystrokes:</b>                            | <b>Actions:</b>  |
|---|--|
| 1. Press [Load Sub].                          | Prompt reads:<br><b>Select submaster(s) to load</b><br><b>To cancel, press CLEAR</b>             |
| 2. Press [9] [Thru] [1][2].                   | Selects submasters 9 through 12<br>Corner reads: <b>Sub 12</b>                                   |
| 3. Press [Cue] (or [Group]).                  | Prompt reads:<br><b>Select cue(s) to load into submaster(s)</b><br><b>To cancel, press CLEAR</b> |
| 4. Press [1] [And] [3] [Thru] [5].            | Selects cues 1, 3, 4, and 5 to copy to submasters 9 through 12<br>Corner reads: <b>Cue 5</b>     |
| 5. Press [Enter]. Submaster copy is complete. | Contents of cues 1, 3, 4, and 5 are copied to submasters 9, 10, 11, and 12, respectively         |

## ***Copying cues or groups to submasters***

To copy a look from a cue or a group to a submaster, follow these steps:

| <b>Keystrokes:</b>                            | <b>Actions:</b>   |
|---|---|
| 1. Press [Blind].                             | Selects Blind display mode  |
| 2. Press [Cue] (or [Group]).                  | Prompt reads:<br><b>Select cue number</b><br><b>To select cue type, press TYPE</b>                          |
| 3. Press [1].                                 | Selects cue to copy<br>Corner reads: <b>Cue 1</b>   |
| 4. Press [Record] [Sub].                      | Prompt reads:<br><b>To record submaster, select number and press ENTER</b><br><b>To cancel, press CLEAR</b> |
| 5. Press [9].                                 | Selects submaster 9<br>Corner reads: <b>Sub 9</b>   |
| 6. Press [Enter]. Submaster copy is complete. | Contents of cue 1 are copied to submaster 9   |

## Clearing submasters

You must be in Blind or Stage display mode to clear the contents of individual submasters. This process erases all level setting instructions and attributes from the submaster. To clear all submasters, use the Clear Submasters option from the Clear Functions menu as described in *Chapter 18, Clear Functions*, on page 198.

To clear submasters, follow these steps:

| <b>Keystrokes:</b>  | <b>Actions:</b>   |
|---|---|
| 1. Press [Blind].   | Selects Blind display   |
| 2. Press [Sub].   | Prompt reads:<br><b>Select submaster number</b>   |
| 3. Press [S6], <b>Delete Sub.</b>   | Prompt reads:<br><b>To delete submaster(s), select number(s) and press ENTER</b><br><b>To cancel, press CLEAR</b> |
| 4. Enter the number of the submaster you want to clear.                   | Corner reads:<br><b>Sub 2</b>   |
| 5. Press [Enter].   | Prompt reads:<br><b>To confirm, press ENTER</b><br><b>To cancel, press CLEAR</b>                                  |
| 6. Press [Enter] to delete the submaster or [Clear] to cancel the action. | Contents of submaster 2 are cleared   |

# Submaster List

The Submaster List (shown below) displays a list of the submasters in your show. Each page is displayed separately, with up to 18 submasters on screen at any time. The Submaster List includes the submaster number, its bump button status, its current level on stage, its upfade, downfade and dwell times, its type, its rate, and its label.

Submasters with recorded levels (pile-on submasters) are displayed in green, inhibitive submasters in red and effect submasters in white. Submasters with no recorded levels are displayed in gray. As you scroll through the submasters, the currently selected submaster's attributes are highlighted in white and the currently selected field is highlighted in yellow. Use [S4], **Previous Page**, and [S5], **Next Page**, to move through the list within each page of submasters.

| Sub | %  | Bump | Up | Dwell | Down | Type    | Rate | Label  |
|-----|----|------|----|-------|------|---------|------|--------|
| 1   |    |      | 1  | 0     | 0    | Pile-on |      | SUB 1  |
| 2   |    |      | 1  | 0     | 0    | Pile-on |      | SUB 2  |
| 3   |    |      | 1  | 0     | 0    | Pile-on |      | SUB 3  |
| 4   |    |      | 1  | 0     | 0    | Pile-on |      | SUB 4  |
| 5   |    |      | 1  | 0     | 0    | Pile-on |      | SUB 5  |
| 6   |    |      | 1  | 0     | 0    | Pile-on |      | SUB 6  |
| 7   |    |      | 1  | 0     | 0    | Pile-on |      | SUB 7  |
| 8   |    |      | 1  | 0     | 0    | Pile-on |      | SUB 8  |
| 9   |    |      | 1  | 0     | 0    | Pile-on |      | SUB 9  |
| 10  | FL |      | 1  | 0     | 0    | Pile-on |      | SUB 10 |
| 11  | FL |      | 1  | 0     | 0    | Pile-on |      | SUB 11 |
| 12  |    |      | 1  | 0     | 0    | Pile-on |      | SUB 12 |
| 13  |    |      | 1  | 0     | 0    | Pile-on |      | SUB 13 |
| 14  | 49 |      | 1  | 0     | 0    | Pile-on |      | SUB 14 |
| 15  | 26 |      | 1  | 0     | 0    | Pile-on |      | SUB 15 |
| 16  | 40 |      | 1  | 0     | 0    | Pile-on |      | SUB 16 |
| 17  |    |      | 1  | 0     | 0    | Pile-on |      | SUB 17 |
| 18  |    |      | 1  | 0     | 0    | Pile-on |      | SUB 18 |

Select submaster number(s) Sub Page 1

S1 S2 S3 S4 S5 S6 S7 S8  
 Bump Status Hold Rate Previous Page Next Page Delete Sub Return

Follow these steps to display Submaster List:

### Keystrokes:

1. Press [Stage] [S7], **More Softkeys**, [S2], **Sub List**.
2. Press [Page] [2] [Enter].
3. Press [Page] [1] [Enter].

### Actions:

- Displays Submaster List, page 1
- Switch from Blind submaster page 1 to page 2
- Switch from Blind submaster page 2 to page 1

## ***Editing attributes in Submaster List***

The Submaster List allows you to edit any attributes shown on the list across a range of submasters simultaneously.

For example, you can assign a five second wait time to submasters 1 through 5 in one command. Follow these steps to do so:

| <b>Keystrokes:</b>                               | <b>Actions:</b>  |
|--|--|
| 1. Press [Blind] [Sub] [S2],<br><b>Sub List.</b> | Displays Submaster List  |
| 2. Press [1] [Thru] [5].                         | Selects submasters 1 through 5<br>Prompt reads:<br><b>Select submaster number(s)</b> |
| 3. Press [Time] and enter [5].                   | Prompt reads:<br><b>Enter upfade time</b>  |
| 4. Press [Enter].                                | Sets upfade time for submasters 1 through 5 to five seconds                          |



# chapter 12

## effects

The screenshot shows a lighting control software interface. At the top, it displays 'Grandmaster 100%', 'Blind 12:35 PM', 'Park Enabled', and 'Cue 100'. Below this, it shows 'Attributes: Positive Bounce' and 'Random rates: 100 / 100'. The main part of the interface is a table with columns for Step, Channel, Time, In, Dwell, Out, Lo, and Hi. The table contains 10 rows of data. Below the table, there are several control panels. One panel shows 'Fader A/B Cue 5' with 'Complete' and '100%' indicators. Another panel shows 'Fader C/D' with 'Clear' and '100%' indicators. A third panel shows 'Cue/Type Time Wait Link Follow Rate' with values '100 EF 0 Hold 100'. A fourth panel shows 'Cue/Type Time Wait Link Follow Rate' with values '6 PT 5 10 5'. A fifth panel shows 'Cue/Type Time Wait Link Follow Rate' with values '2 5 10 5'. At the bottom, there are several buttons: 'Step', 'Cue List', 'Rate', 'Previous Page', 'Next Page', 'Delete Cue', 'More Softkeys', and 'Toad exits'.

| Step | Channel | Time | In | Dwell | Out | Lo | Hi |
|------|---------|------|----|-------|-----|----|----|
| 1    | 1       | 26   | 51 | 76    | 101 | 0  | FL |
| 2    | 2       | 27   | 52 | 77    | 102 | 0  | FL |
| 3    | 3       | 28   | 53 | 78    | 103 | 0  | FL |
| 4    | 4       | 29   | 54 | 79    | 104 | 0  | FL |
| 5    | 5       | 30   | 55 | 80    | 105 | 0  | FL |
| 6    | 6       | 31   | 56 | 81    | 106 | 0  | FL |
| 7    | 7       | 32   | 57 | 82    | 107 | 0  | FL |
| 8    | 8       | 33   | 58 | 83    | 108 | 0  | FL |
| 9    | 9       | 34   | 59 | 84    | 109 | 0  | FL |
| 10   | 10      | 35   | 60 | 85    | 110 | 0  | FL |

An effect runs steps, containing channels, in a variety of patterns called chases. An effect can be positive, with lights starting off and being turned on in patterns, or negative, with lights starting on and being turned off in patterns.

Insight 2 allows you to record effects, each with up to 100 steps, into cues or submasters. Each effect includes level and timing controls for the steps in the effect, and overall timing controls for the effect itself. Each effect step can last for up to 99:59 minutes.

*Note: Channel levels are not affected by an effect until a step runs that specifically addresses the channel.*

This chapter includes the following sections:

- Steps
- Creating steps
- Configuring effects
- Modifying effects
- Running an effect cue
- Using an effect submaster

# Steps

An effect may consist of up to 100 steps. A step is made up of elements. Elements may be either channels or groups. Each step may contain up to ten elements. For example, channels 1 through 10 would constitute ten elements, filling the step. However, a group containing channels 1 through 10 would constitute only one element, allowing nine more channels or groups to be added.

Each step in an effect is assigned a high and low level, a step time, and an in, dwell, and out time.

## **Step time**

Step time is the time between the beginning of a step and the beginning of the next step. Default Step time is 0.2 seconds.

## **In time**

In a positive effect, the time the step takes to fade from its starting level to its high level is the In time. In a negative effect, it is the time it takes to fade from its starting level to its low level. Default In time is zero seconds.

## **Dwell time**

Dwell time is the length of time between the end of the In fade and the start of the Out fade. Default Dwell time is zero.

## **Out time**

In a positive effect, the time the step takes to fade from its high level to its low level is the Out time. In a negative effect, it is the time it takes the step to fade from its low level to its high level. Default Out time is zero seconds.

*Note: If the In/Dwell/Out times are 0/0/0, the step will rise instantly to its High level and remain there until the Step time has elapsed. Then it will drop instantly to its Low level.*

## **High and Low levels**

The High and Low levels represent the range of levels channels in the step are allowed to reach. Default High level is Full, default Low level is zero.

*Note: If you create an effect step that includes groups, its high and low values are proportional levels.*

# Creating steps

Create an effect by selecting the effect type for a cue or submaster, then creating a series of steps in the Effect display. Use the arrow keys to move around the Effect display and enter settings. When you create a new step, it takes the previous step's attributes as its defaults. You may then edit the new step.

To edit a step attribute, use the arrow keys to select the field of the attribute you wish to edit. Use the keypad to enter the new setting for that attribute. Then, either press [Enter] to confirm the change without leaving the attribute field or press any arrow key to make the change and move to a different attribute field. You can also use softkeys to move from field to field.

Follow these instructions to create a series of steps:

| <b>Keystrokes:</b>   | <b>Action:</b>   |
|--|--|
| 1. Press [Blind].  | Selects the Blind display  |
| 2. Press [Cue] or [Sub] [1].   | Selects cue or submaster 1<br>Prompt reads:<br><b>Select cue number</b><br><b>To select cue type, press TYPE</b><br>or...<br><b>Select submaster number</b><br><b>To select submaster type, press TYPE</b> |
| 3. Press [Type].   | Prompt reads:<br><b>Select fade type (1 = Crossfade, 2 = Allfade, 3 = Effect, or 4 = Subroutine)</b><br>or...<br><b>Select submaster type (1 = Pile-on, 2 = Inhibitive, 3 = Effect)</b>                    |
| 4. Press [3].  | Identifies cue or submaster 1 as an effect. Selects Effect display<br>Prompt reads:<br><b>Select step numbers</b>  |
| 5. If you are creating an effect submaster, press [S7], <b>More Softkeys</b> ,                     |  |
| 6. Press [S1], <b>Step</b> , and enter the number of the step to edit. Press [Enter].              | Prompt reads:<br><b>Select channel numbers (Precede with AND to add to existing step, or EXCEPT to delete from step)</b>   |
| 7. Use the keypad to enter the channels or groups you want to include in the step, then press [→]. | Prompt reads:<br><b>Select step time</b>   |
| 8. Use the keypad to enter step time (range is 0 to 9:59 minutes), then press [→].                 | Prompt reads:<br><b>Enter step in time</b>   |

9. Use the keypad to enter the **In** time, then press [→].  
Prompt reads:  
**Enter step dwell time**
10. Use the keypad to enter **Dwell** time, then press [→].  
Prompt reads:  
**Enter step out time**
11. Use the keypad to enter **Out** time, then press [→].  
Prompt reads:  
**Select low level**
12. Use the keypad to enter the low level, then press [→].  
Prompt reads:  
**Enter high level**
13. Use the keypad to enter high level, then press [Enter].  
Prompt reads:  
**Select step numbers**
14. Repeat steps 5 through 13 for each effect step you wish to create.
15. Press [Record], enter the cue or submaster number and press [Enter]. Press [Clear] to cancel.  
Cue or submaster containing effect is recorded

## Default element assignment

Rather than assign elements to steps one at a time, you can assign a range of elements to a range of steps on a one-to-one basis.

The console assigns elements (channels or groups) to each step in turn, i.e., channel 1 to step 1, channel 2 to step 2, and so on. If there are more elements than steps, Insight 2 assigns an element to each step, then returns to the first step and continues assigning elements, one per step, until all are assigned.

Follow these steps to create an effect that uses a one-to-one channel assignment. In the example, channels 1 through 22 are assigned to steps 1 through 10, creating a ten-step effect.

### Keystrokes:

1. Press [Blind] [Cue] [2] [Type] [3].
2. Press [S1], **Step**, and enter [1] [Thru] [1][0].
3. Press [Enter].
4. Press [1] [Thru] [2][2], the range of channels to assign to the steps.
5. Press [Enter].

### Action:

Selects cue 2 in the Blind display and designates it as an effect cue

Prompt reads:

**Select step numbers**

Prompt reads:

**Select channel numbers**

Prompt reads:

**Select channel numbers**

Channels are assigned to steps as indicated above; see chart below

| <b>Step number:</b> | <b>Contains channels:</b> |    |    |
|---------------------|---------------------------|----|----|
| Step 1              | 1                         | 11 | 21 |
| Step 2              | 2                         | 12 | 22 |
| Step 3              | 3                         | 13 |    |
| Step 4              | 4                         | 14 |    |
| Step 5              | 5                         | 15 |    |
| Step 6              | 6                         | 16 |    |
| Step 7              | 7                         | 17 |    |
| Step 8              | 8                         | 18 |    |
| Step 9              | 9                         | 19 |    |
| Step 10             | 10                        | 20 |    |

# Controlling effects

Effect steps are controlled by assigned attributes, fade times and rates. In addition, the cue or submaster containing the effect may be assigned fade times and rates that apply to the effect overall.

## Attributes

Attributes control how the effect plays its steps. Press [S7], **More Soft-keys**, [S8], **Attribute**, to reveal the attribute softkeys. Assign attributes using the following rules:

- All effects are either Positive or Negative. When you initially create an effect, it defaults to Positive.
- Alternate, Reverse, Bounce, and Build can be applied in any combination to a Positive or Negative effect.
- Random can be applied to any Positive or Negative effect. Random may not be combined with Alternate, Reverse, Bounce, or Build.

*Note: In the following descriptions, "On" means elements are set to their high level, "Off" means they are set to their low level.*

|                       |  |
|-----------------------|--|
| <b>[S1] Positive</b>  | In a positive effect, all elements start Off. Each step turns its assigned elements On and the previous step's elements Off.   |
| <b>[S1] Negative</b>  | In a negative effect, all elements start On. Each step turns its assigned elements Off and the previous step's elements On.  |
|                       | <i>Note: [S1], <b>Positive/Negative</b>, switches back and forth between positive and negative.</i>  |
| <b>[S2] Alternate</b> | The effect alternates between positive and negative chases through the steps. The first pass is positive if the effect is positive, negative if the effect is negative.  |
| <b>[S3] Reverse</b>   | Steps run in reverse numerical order.  |
| <b>[S4] Bounce</b>    | Steps run first in forward, then in reverse order. Subsequent passes alternate between forward and reverse.  |
| <b>[S5] Build</b>     | All elements are Off at the beginning of the chase. Each step turns its assigned elements On, and leaves the previous step On. At the end of the chase, all steps are On; they all turn Off to start the next pass.<br><br>In a negative effect, all steps are On at the beginning of the chase. Each step turns its assigned elements Off, and leaves previous step elements Off. At the end of the chase, all elements are Off; they all turn On to start the next pass. |
| <b>[S6] Random</b>    | A Random effect plays steps back in random order. Random is ideal for creating lightning, flashing, or strobe effects.   |

## ***Assigning attributes***

Follow these steps to assign attributes to the effect you created in the previous example.

### **Keystrokes:**

1. Press [Blind] [Cue] [2].
2. Press [S7], **More Softkeys**, [S8], **Attribute**.
3. Select attributes from the softkeys on the screen.

### **Action:**

- Selects cue 2 in the Blind display
- Displays attributes across the bottom of the screen  
Prompt reads:  
**Select effect attributes**
- Selected patterns are displayed at the top of the effects display

*Note: To remove an attribute, select it again.*

## Effect fade times

Each effect has an overall upfade, dwell and downfade time. When you create an effect cue, the times default to the cue fade times in your system settings. If you have not changed the default settings, this means an upfade of five seconds, a dwell of **hold**, and a downfade of five seconds. See *Setting default fade times* on page 17. [Time] allows the user to set the upfade, dwell and downfade time for the overall effect.

*Note: Dwell time is the length of time the effect runs between the upfade of the first step and the downfade of the last step. **Hold** assigns an infinite dwell time, meaning the effect runs until the associated [Clear] key or bump button is pressed to start the downfade.*

Times may be expressed in minutes and seconds, or as fractions of seconds (in decimal format). Times can be programmed from .1 second to 99:59 minutes. Acceptable time values include: .2 (.2 seconds), 00:12 (12 seconds), 5.5 (5.5 seconds), or 5:30 (five minutes, 30 seconds).

### Change upfade, dwell and downfade

Follow these steps to change the effect's fade times.

| Keystrokes:  | Action:  |
|--|--|
| 1. Press [Blind] [Cue] [2].  | Selects cue 2 in the Blind display   |
| 2. Press [Time] and enter the upfade time.                                 | Prompt reads:<br><b>Enter effect upfade time</b>                           |
| 3. Press [Time] and enter the dwell time.                                  | Prompt reads:<br><b>Enter effect dwell time</b>                            |
| 4. Press [Time] and enter the downfade time. Press [Clear] for hold dwell. | Prompt reads:<br><b>Enter effect downfade time</b>                         |
| 5. Press [Enter].  | Fade time entry is complete<br>Prompt reads:<br><b>Select step numbers</b> |

### Change upfade only

Follow these steps to change only the effect's upfade time.

| Keystrokes:                       | Action:  |
|-----------------------------------|--|
| 1. Press [Blind] [Cue] [2].       | Selects cue 2 in the Blind display               |
| 2. Press [Time].                  | Prompt reads:<br><b>Enter effect upfade time</b> |
| 3. Enter the upfade time.         | Prompt reads:<br><b>Enter effect upfade time</b> |
| 4. Press [Enter] [Enter] [Enter]. | Prompt reads:<br><b>Select step numbers</b>      |

## ***Change downfade only***

Follow these steps to change only the effect's downfade time.

| <b>Keystrokes:</b>             | <b>Action:</b>                                     |
|--------------------------------|--|
| 1. Press [Blind] [Cue] [2].    | Selects cue 2 in the Blind display                 |
| 2. Press [Time] [Time] [Time]. | Prompt reads:<br><b>Enter effect downfade time</b> |
| 3. Enter the downfade time.    | Prompt reads:<br><b>Enter effect downfade time</b> |
| 4. Press [Enter].              | Prompt reads:<br><b>Select step numbers</b>        |

## ***Change dwell only***

Follow these steps to change only the effect's dwell time.

| <b>Keystrokes:</b>          | <b>Action:</b>                                  |
|-----------------------------|---|
| 1. Press [Blind] [Cue] [2]. | Selects cue 2 in the Blind display              |
| 2. Press [Time] [Time].     | Prompt reads:<br><b>Enter effect dwell time</b> |
| 3. Enter the dwell time.    | Prompt reads:<br><b>Enter effect dwell time</b> |
| 4. Press [Enter] [Enter].   | Prompt reads:<br><b>Select step numbers</b>     |

## ***Reset Hold dwell time***

If the dwell time is set to **Hold**, an effect submaster will continue to run until you press the bump button. An effect cue will continue to run until you press either [Go] or [Hold] [Hold]. To reset the dwell time to **Hold** follow these steps:

| <b>Keystrokes:</b>          | <b>Action:</b>   |
|-----------------------------|--|
| 1. Press [Blind] [Cue] [2]. | Selects cue 2 in the Blind display   |
| 2. Press [Time] [Time].     | Prompt reads:<br><b>Enter effect dwell time</b>                              |
| 3. Press [Clear].           | Prompt reads:<br><b>Enter effect dwell time</b>                              |
| 4. Press [Enter] [Enter].   | Dwell time set to <b>Hold</b><br>Prompt reads:<br><b>Select step numbers</b> |

## Using a random rate

An effect with a random rate runs at varying speeds, changing at random, within a range that you select.

The console applies a random rate to the assigned step time and to the step fade times.

To assign random rate and to select your maximum and minimum rates (from 0 percent to 2,000 percent), follow the steps below:

| <b>Keystroke:</b>   | <b>Action:</b>  |
|---|---|
| 1. Press [Blind] [Cue] [2].                                     | Selects cue 2 in the Blind display  |
| 2. Press [S7], <b>More Soft-keys</b> , [S8], <b>Attribute</b> . | Displays available attributes across the bottom of the screen               |
| 3. Press [S7], <b>Random Rate</b> .                             | Prompt reads:<br><b>Select low random rate<br/>(0 to 2000, 100=Normal)</b>  |
| 4. Enter the slowest desired effect rate. Press [Enter].        | Prompt reads:<br><b>Select high random rate<br/>(0 to 2000, 100=Normal)</b> |
| 5. Enter the highest desired effect rate.                       |   |
| 6. Press [Enter].   | Prompt reads:<br><b>Select step number</b>                                  |

*Note: You can control an effect's rate by adjusting the rate of the submaster or cue in which the effect is recorded. Adjusting the rate does not affect the overall Up/Dwell/Down times for the cue or submaster. It does, however, speed up or slow down the individual steps.*

*For more information about controlling cue or submaster rates, see pages 105 and 138.*

## Modifying effects

Insight 2 allows you to modify recorded effects by adding or deleting effect steps, changing step attributes, and adding or deleting step elements.

### Inserting steps

You can insert a new step at any point in an effect. For example, to insert a step between steps 4 and 5, follow these steps:

#### Keystrokes:

1. Press [Blind] [Cue] [2].
2. Press [S7], **More Soft-keys**.
3. Press [S5], **Insert Step**.
4. Use the [↑] and [↓] keys to highlight the step you wish to insert or...  
Enter the number of the step.
5. Press [Enter].
6. Enter desired channels and settings.

#### Action:

Selects cue 2 in the Blind display

Prompt reads:

**Select step number to insert, then press ENTER**  
**To cancel, press CLEAR**

Prompt reads:

**Select step number to insert, then press ENTER**  
**To cancel, press CLEAR**

Prompt reads:

**Select channel numbers**  
**(Precede with AND to add to existing step, or EXCEPT to delete from step**

The new step is inserted in place of the old one. The old step 5 becomes step 6; step 6 becomes step 7 and so on. The timing and level attributes from step 4 are set as initial defaults in the new step 5.

## Deleting steps

You may also delete steps from an effect. For example, to delete step 5, follow these instructions:

| <b>Keystrokes:</b>   | <b>Action:</b>  |
|--|---|
| 1. Press [Blind] [Cue] [2].  | Selects cue 2 in the Blind display  |
| 2. Press [S7], <b>More Soft-keys</b> .                                 |   |
| 3. Press [S6], <b>Delete Step</b> .                                    | Prompt reads:<br><b>Select step number to delete, then press ENTER</b><br><b>To cancel, press CLEAR</b>                   |
| 4. Use the [↑] and [↓] keys to highlight step 5<br>or...<br>Press [5]. | Selects step 5<br>Prompt reads:<br><b>Select step number to insert, then press ENTER</b><br><b>To cancel, press CLEAR</b> |
| 5. Press [Enter], or press [Clear] to cancel.                          | Deletes step 5; Step 6 becomes step 5; step 7 becomes step 6 and so on<br>Prompt reads:<br><b>Select step numbers</b>     |
| 6. Press [Record] [Enter],   | Records your changes to the cue   |

## Editing step characteristics

Use the arrow keys to select step characteristics to edit. For example, to edit a step's **In** time, follow these instructions:

| <b>Keystrokes:</b>   | <b>Action:</b>                              |
|--|---|
| 1. Press [Blind] [Cue] [2].  | Selects cue 2 in the Blind display          |
| 2. Use [↓] to select the step you want to edit, for example step 2<br>or...<br>Press [S1], <b>Step</b> , [2].                          | Prompt reads:<br><b>Select step numbers</b> |
| 3. Use [→] to highlight the <b>In</b> time field in step 2<br>or...<br>Press [S7], <b>More Soft-keys</b> , [S3], <b>In Dwell Out</b> . | Prompt reads:<br><b>Enter step in time</b>  |
| 4. Press [8], the new <b>In</b> time.  | New step time is added                      |

## Adding elements

To add a channel or group to a step, follow these steps:

| <b>Keystrokes:</b>   | <b>Action:</b>   |
|--|--|
| 1. Press [Blind] [Cue] [2].  | Selects cue 2 in the Blind display   |
| 2. Select the step you wish to modify using [↓] and [↑], or press [S1], <b>Step</b> , and enter the step number. | Prompt reads:<br><b>Select step numbers</b>  |
| 3. Press [Enter] [And].  | Prompt reads:<br><b>Select channel numbers (Precede with AND to add to existing step, or EXCEPT to delete from step)</b> |
| 4. Enter the channel or group number to add.   | Prompt reads:<br><b>Select channel numbers</b>   |
| 5. Press [Enter].  | Channel 7 is added to element list<br>Prompt reads:<br><b>Select step numbers</b>  |
| 6. Press [Record] [Enter].   | Records your changes to the cue  |

*Note: If you enter elements without using [And] or [Except], the channels or groups you enter replace the current element list.*

## Deleting elements

To remove a channel or group from a step, follow these steps:

| <b>Keystrokes:</b>   | <b>Action:</b>   |
|--|--|
| 1. Press [Blind] [Cue] [2].  | Selects cue 2 in the Blind display.  |
| 2. Select the step you wish to modify using [↓] and [↑], or press [S1], <b>Step</b> , and enter the step number. | Prompt reads:<br><b>Select step numbers</b>  |
| 3. Press [Enter] [Except].   | Prompt reads:<br><b>Select channel numbers (Precede with AND to add to existing step, or EXCEPT to delete from step)</b> |
| 4. Enter the channel or group number to remove.  | Prompt reads:<br><b>Select channel numbers</b>   |
| 5. Press [Enter].  | Prompt reads:<br><b>Select step numbers</b>  |
| 6. Press [Record] [Enter],   | Records your changes to the cue  |

## ***Running an effect cue***

Play back effects recorded as cues on the console's A/B or C/D faders, just as you would any other cue. The effect will run, using the cue's Up, Dwell and Down times to determine how long the cue lasts. To run the cue, press [Cue], enter the effect cue number, and press [Go].

An effect cue with a **Hold** dwell time runs on the fader until you press that fader's [Clear] key to begin the downfade. Press [Clear] once to fade out an effect cue in the recorded downfade time.

You may use the playback sliders to manually control the cue, allowing you to fade the effect up and down with the playback slider.

*Note: Press the fader's [Clear] key twice to cancel an effect from the fader immediately.*

## ***Using an effect submaster***

An effect recorded to a submaster interacts with cues and other submasters on a pile-on basis. Bring up the effect by pressing the submaster's bump button or raising the slider.

An effect submaster fades proportionally between zero and the effect's high level. The slider acts as a master. If the effect's low level is normally 10 percent, moving the slider to 50 percent will reduce the effect's low level to 5 percent.

*Note: See Adding a rate to a submaster on page 133 for information on changing the rate of a submaster.*

# chapter 13

## subroutines

A subroutine is a cue that controls the playback of a series of recorded cues. Subroutines are similar to linked cues, except that they have more playback options.

You can use subroutines and effects to create similar looks. However, subroutines have some advantages over effects. Since each step of a subroutine is a cue with channels set at proportional levels, you can create loops or chases with proportional looks. In an effect, channels are assigned to steps, but no levels are assigned. Thus, all channels in a step are at the same level. You can also create nested loops, or even use an effect cue as a step in a subroutine.

This chapter contains the following sections:

- Steps
- Cue steps
- Style steps
- Creating a subroutine
- Editing a subroutine
- Deleting a step
- Inserting a step

## **Steps**

All subroutine steps are either cue steps or style steps. A cue step contains an existing recorded cue. The subroutine lets you change levels and fade rates for the cue step without changing the original cues. A cue step may contain an effect cue

A style step contains an instruction that controls the subroutine's playback pattern. This allows you to run loops, run bounces, pause the subroutine until you press go, or end the subroutine and jump to any other cue. The following display shows a subroutine that runs a series of cues in a loop.

The next two pages describe the types of cue and style steps that are available.

## **Cue steps**

There are two types of cue step, crossfade and allfade.

### **Crossfade**

In a crossfade step, all increasing levels fade in the upfade time; all decreasing levels fade in the downfade time.

### **Allfade**

In an allfade step, all channels in both faders fade to a level that you choose and assign to the step.

## Style steps

The following playback styles are available for subroutines. A style is assigned to a step. When the subroutine runs, the steps play back in numeric order, until the subroutine reaches a style step. The style step then determines whether the subroutine will loop, bounce, hold, or end and run a different cue.

|                    |   |
|--------------------|---|
| <b>Loop</b>        | <p>The subroutine runs through steps until it reaches a Loop step. It then returns to the first step, and repeats the sequence for the number of times you specify.</p> <p>When you create the Loop step, enter the number of times you want the loop to return to the top of the step list. If you enter <b>5</b>, the sequence will play six times. Enter <b>0</b> to create a continuous loop.</p>                   |
| <b>Bounce</b>      | <p>The subroutine runs through steps until it reaches a Bounce step. It then runs back through the steps in reverse order, and repeats the sequence for the number of times you specify.</p> <p>When you create the Bounce step, enter the number of times you want the subroutine to bounce. One bounce equals running through the sequence forward once and reverse once. Enter <b>0</b> for a continuous bounce.</p> |
| <b>Jump-to-cue</b> | <p>The subroutine runs through steps until it reaches a Jump-to-cue step. It then automatically starts another cue which is not included in the subroutine. You can jump to any type of cue: regular, subroutine or effect.</p> <p>When you create the Jump-to-cue step, enter the number of the cue to which to jump.</p>  |
| <b>Hold-for-Go</b> | <p>The subroutine runs through steps until it reaches a Hold-for-Go step. It then pauses until you press [Go].</p>  |

## Subroutine attributes

The following attributes may be applied to each cue step.

|                    |   |
|--------------------|---|
| <b>Level</b>       | <p>Sets an intensity level for the cue within the subroutine. The level proportionally affects the channel levels assigned to the original cue. Levels must be entered as two-digit numbers (e.g., <b>20</b> for 20 percent, <b>05</b> for five percent). Use [Full] for 100 percent.</p> |
| <b>Fade times</b>  | <p>Upfade times may range from .1 seconds to 99:59 minutes. If you do not enter a time, the downfade will match the upfade.</p>   |
| <b>Follow time</b> | <p>Follow time is the time between the start of one step and the start of the next. Follow times may range from .1 seconds to 99:59 minutes.</p>  |

# Creating subroutines

Each subroutine can hold up to 100 steps. Each step lists a cue or a style.

To create a subroutine, follow these steps:

- | <b>Keystrokes:</b>  | <b>Action:</b>   |
|---|--|
| 1. Create the cues you want to use in your subroutine.                                |  |
| 2. Press [Blind].<br>(You must be in Blind mode to create subroutines.)               | Displays Blind mode screen   |
| 3. Press [Cue] [7].   | Selects cue 7 to be your subroutine cue  |
| 4. Press [Type].  | Displays fade type menu<br>Prompt reads: <b>Select fade type (1 = Crossfade, 2 = Allfade, 3 = Effect, or 4 = Subroutine)</b> |
| 5. Press [4], <b>Subroutine</b> .<br>Insight 2 displays the screen illustrated below. | Select subroutine fade type<br>Prompt reads: <b>Select step number(s), then press ENTER</b>                                  |

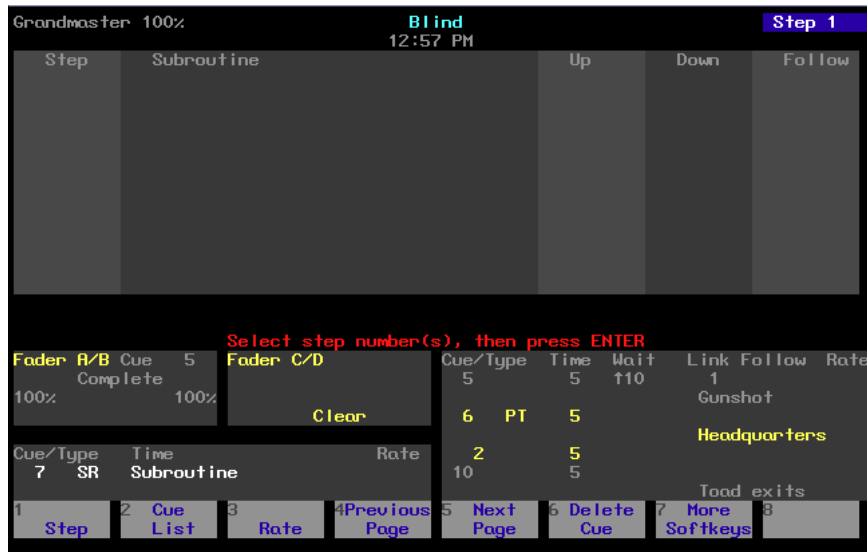

- |                   |   |
|-------------------|---|
| 6. Press [1] [→]. | Selects step 1<br>Prompt reads:<br><b>Enter cue number to fade, or press STYLE to change step type</b>            |
| 7. Press [1] [→]. | Selects cue 1 for step 1 of the subroutine<br>Prompt reads: <b>Enter type of cue (1 = Crossfade, 2 = Allfade)</b> |
| 8. Press [1].     | Designates cue as a crossfade within the subroutine<br>Prompt reads: <b>Enter intensity</b>                       |

9. Press [5][5].  
Selects a level of 55 percent for the cue within the subroutine  
Prompt reads: **Enter upfade time**
10. Press [8] [→].  
Sets an upfade time of eight seconds  
Prompt reads: **Enter downfade time**
11. Press [→].  
Sets a downfade time of eight seconds  
Prompt reads: **Enter follow time**
12. Press [2][0].  
Sets a follow time of 20 seconds. Step 1 is now complete
13. Press [S1], **Step**, [2] [Enter].  
Selects step 2 to edit
14. Repeat steps 7 through 13, altering attributes as desired, to add additional cues as subroutine steps.
15. Press [S1], **Step**, [6] [Enter].  
Selects step 6 to edit
16. Press [S2], **Style**, to select a subroutine style. (You may need to press [S7], **More Softkeys**, first.)  
Styles are described on page 161.  
Prompt reads: **Select style of subroutine command**  
**(1 = Loop, 2 = Bounce, 3 = Jump to cue, 4 = Hold for go)**
17. Press [3] [Enter].  
Selects Jump to cue style for step 6  
Prompt reads:  
**Select cue number**
18. Press [8] [Enter].  
Selects cue 8 for Jump to cue. When subroutine reaches step 6, the subroutine ends and runs cue 8
19. Complete entering all cue steps and style steps as described above.
20. Press [Record], enter cue number, and press [Enter] to record subroutine cue.

## ***Editing a subroutine***

To edit a subroutine, select the step you wish to change by pressing [S1], **Step**, and entering the step number. Use [And] and [Thru] to select multiple steps. Selected steps are displayed in white on the monitor.

*Note: If you select a range of steps, only cue steps will be selected. Style steps may only be edited individually and will be left out of selected ranges.*

Once the step is selected, choose the attribute you wish to edit by pressing one of the following softkeys. The selected attribute is displayed in yellow on the monitor.

- |                             |  |
|-----------------------------|--|
| [S2], <b>Style</b>          | Allows you to select a style from the style menu.                          |
| [S3], <b>Select Cue</b>     | Allows you to enter a cue number for the selected step.                    |
| [S4], <b>Type/Level</b>     | Allows you to select a crossfade or an allfade and to set intensity level. |
| [S8], <b>Up/Down/Follow</b> | Allows you to set upfade and downfade times and to set follow time.        |

Once you finish editing the subroutine, press [Record] [Enter] to save your changes.

*Note: You may use the arrow keys to move from one field or line to the next. For example, press [↓] to select the next step, or press [→] to enter information one field to the right of the current field.*

## ***Deleting a step***

Press [S6], **Delete Step**, and enter the step number. Then press [Enter]. Insight 2 deletes the selected step and renumbers the remaining steps.

## ***Inserting a step***

Press [S1], **Step**, and enter the step number where you want to insert the new step. Then press [Enter]. Insight 2 inserts a blank step before the selected step.

# *chapter 14*

## *MACROS*

A macro allows you to record a series of keystrokes and later replay it with one or two keystrokes. This can simplify complex tasks that you perform often. You can program up to 2,000 macros in Insight 2, depending on how large they are.

This chapter includes the following sections

- Creating macros
- Playing macros
- Modifying macros
- Clearing macros
- Copying macros
- Sample macros

# Creating macros

There are two ways to create a macro. You can create it in Macro display mode, entering and editing keystrokes without actually executing the instructions, or you can use Insight 2's Learn mode to record a sequence of keystrokes as you perform the operation.

You can include any key or button on the console except [Enter Macro] in a macro. You cannot enter slider settings or wheel movements. Each macro can contain up to 50 keystrokes. In addition, you can link macros.

## Using Learn

Insight 2's Learn function allows you to create a macro by performing an actual sequence of keystrokes. Insight 2 records the keystrokes as you make them. The recorded keystroke sequence can then be rerun by pressing the appropriate macro key. Once you record a macro in Learn mode you can edit the sequence in Macro mode to adjust its operation. Learn works in any display mode except the Macro Editing display and the Designer's Worksheet Editing display.

To create a sample macro using Learn, follow these steps:

| <b>Keystrokes:</b>                                  | <b>Action:</b>  |
|---|---|
| 1. Press [Stage].                                   | Selects Live display mode   |
| 2. Press [Learn].                                   | Prompt reads:<br><b>Select macro number to learn, then press ENTER</b><br><b>To cancel, press CLEAR</b>   |
| 3. Press [7] [Enter].                               | <b>Learning Macro 7</b> flashes in red in the upper left corner of the monitor<br>Prompt reads:<br><b>Select operation(s) for this macro – press ENTER MACRO when done (Wheels and sliders are not valid entries in macros)</b> |
| 4. Enter [Channel] [1] [Thru] [5] [At] [5] [Enter]. | Sets channels 1 through 5 at 50 percent   |
| 5. Press [Macro Wait].                              | Prompt reads:<br><b>Enter wait time</b><br><b>Press ENTER when done</b>   |
| 6. Press [5] [Enter].                               | Inserts a five second wait into the macro<br>Prompt reads:<br><b>Select operation(s) for this macro – press ENTER MACRO when done (Wheels and sliders are not valid entries in macros)</b>                                      |
| 7. Enter [Channel] [1] [Thru] [1][0] [Full].        | Sets channels 1 through 10 at Full  |
| 8. Press [Macro Wait].                              | Prompt reads:<br><b>Enter wait time</b><br><b>Press ENTER when done</b>   |

- |   |  |
|---|--|
| 9. Press [5] [Enter].                                   | Inserts a five second wait into the macro<br>Prompt reads:<br><b>Select operation(s) for this macro –<br/>press ENTER MACRO when done<br/>(Wheels and sliders are not valid<br/>entries in macros)</b> |
| 10. Enter [Channel] [1] [Thru] [1][0] [At] [0] [Enter]. | Sets channels 1 through 10 at zero   |
| 11. Press [Enter Macro].                                | Concludes macro recording  |
| 12. Press [M*] [7] [Enter].                             | Macro 7 runs. Channels 1 through 5 rise to 50 percent. After five seconds, channels 1 through 10 rise to Full. After five seconds, levels drop to zero   |

*Note: If your macro needs to contain softkeys from display modes other than the Macro Editing display, you must use Learn to create it.*

## Using Macro display mode

Macro display mode allows you to create or edit macros without affecting channel levels. Softkeys, [Enter Macro], [←], and [→] may not be entered in a macro in Macro display mode.



Follow these steps to create a macro to record a show to diskette:

- | Keystrokes:  | Action:  |
|--|--|
| 1. Press [Setup].                                      | Selects Setup display screen   |
| 2. Select 8, <b>Macro Editing</b> , and press [Enter]. | Selects Macro display screen<br>Prompt reads:<br><b>Select macro number, then press ENTER</b>  |
| 3. Press [8] [Enter].                                  | Blank macro created<br>Prompt reads:<br><b>Select operation(s) for this macro – press ENTER MACRO when done (Wheels and sliders are not valid entries in macros)</b> |
| 4. Press [Setup] [3] [Enter].                          | Enters setup display<br>Macro contents line reads: <b>SETUP 3 ENTER</b>  |
| 5. Press [1] [Enter].                                  | Selects <b>Write Show To Disk</b><br>Macro contents line reads: <b>SETUP 3 ENTER 1 ENTER</b>   |
| 6. Press [Enter].                                      | Confirms selection<br>Macro contents line reads: <b>SETUP 3 ENTER 1 ENTER ENTER</b>  |
| 7. Press [Enter Macro].                                | Stores macro 8   |

*Caution: Insight 2 does not check the sequence of keystrokes to confirm that it will work. It is possible to create macros that don't work. When you run the macro, you will receive whatever error messages are appropriate.*

To avoid problems, you should plan your macro before you start recording it by determining exactly what keystrokes you want to include. You might want to do this by running through the task and writing down each keystroke.

## **Next macro**

When you press [Enter Macro], the Macro display selects the next macro. If you wish to begin recording the next macro, press [Enter].

## **Macro wait**

To program a pause in the macro, press [Macro Wait] at the point in the macro where you want the pause to occur. Enter the time you would like the macro to hold, then press [Enter]. Continue to enter remaining macro commands.

Times may be expressed in minutes and seconds, or as fractions of seconds (in decimal format). Times can be programmed from .1 second to 99:59 minutes. Acceptable time values include: .2 (.2 seconds), 00:12 (12 seconds), 5.5 (5.5 seconds), or 5:30 (five minutes, 30 seconds).

## Linking macros

Any macro may end with a link to another macro. When macros are linked, the first macro runs, then the second macro follows automatically. Press the appropriate macro key at the end of your sequence to create the link. Pressing the macro key automatically ends and stores the macro.

For example, to create a macro that sets all active channels to 50 percent, fades them out, then runs another macro, follow these steps:

| Keystrokes:                              | Action:   |
|--|---|
| 1. Press [Setup] [8] [Enter].            | Selects Macro editing mode  |
| 2. Press [1] [Enter].                    | Selects macro 1 to create<br>Prompt reads:<br><b>Select operation(s) for this macro –<br/>press MACRO ENTER when done<br/>(Wheels and potentiometers are<br/>not valid entries in macros)</b> |
| 3. Press [Enter] [At] [5][0]<br>[Enter]. | Sets all active channels to 50 percent<br>Macro line reads:<br><b>ENTER AT 5 0 ENTER</b>  |
| 4. Press [Macro Wait] [1][0]<br>[Enter]. | Macro pauses for ten seconds<br>Macro line reads:<br><b>ENTER AT 5 0 ENTER Mwait-10</b>   |
| 5. Press [Enter] [At] [0]<br>[Enter]     | Fades all active channels out<br>Macro line reads:<br><b>ENTER AT 5 0 ENTER Mwait-10<br/>ENTER AT 0 ENTER</b>   |
| 6. Press [M3].                           | Stores macro. Links macro to macro 3<br>Macro line reads:<br><b>ENTER AT 5 0 ENTER Mwait-10<br/>ENTER AT 0 ENTER M3</b>   |

*Note: You may also link a macro to a cue so the macro will run at the same time the cue does. See Chapter 6, Working with cues, for more details.*

## Using submasters in macros

Submaster bump buttons can function in macros in three different ways: as a normal bump button; to always fade a submaster to full (regardless of its current condition); or to always fade a submaster out (regardless of its current condition).

To include a bump button that starts a timed submaster or changes the direction of a running fade, press the submaster bump button while programming the macro.

Use [S1], **On Sub-Bump**, to fade the submaster up, regardless of its current setting. Use [S2], **Off Sub-Bump**, to fade a submaster out, regardless of its current setting.

To create a macro that turns a submaster on for five seconds, then turns it off, follow these steps:

| Keystrokes:   | Action:   |
|---|---|
| 1. Press [Setup] [8] [Enter].                                     | Selects Macro editing mode  |
| 2. Press [4] [Enter].   | Selects macro 4 to create<br>Prompt reads: <b>Select operation(s) for this macro – press ENTER MACRO when done (Wheels and sliders are not valid entries in macros)</b> |
| 3. Press [S7], <b>More Soft-keys</b> , [S1], <b>On Sub-Bump</b> . | Macro line reads: <b>OnBump</b><br>Prompt reads: <b>Enter submaster number</b>  |
| 4. Press [3] [Enter].   | Macro line reads: <b>OnBump3</b>  |
| 5. Press [Macro Wait].  | Macro line reads: <b>OnBump3 Mwait-0</b>  |
| 6. Enter [5] and press [Enter].                                   | Macro line reads: <b>OnBump3 Mwait-5</b>  |
| 7. Press [S2], <b>Off Sub-Bump</b> .                              | Macro line reads: <b>OnBump3 Mwait-5 OffBump</b><br>Prompt reads: <b>Enter submaster number</b>   |
| 8. Press [3] [Enter].   | Macro line reads: <b>OnBump3 Mwait-5 OffBump3</b>   |
| 9. Press [Enter Macro].   | Records macro 4; leaves editing mode  |
| 10. Press [Stage] [M4].   | Macro runs  |

## Playing macros

As a macro runs, the LED in the macro's key flashes. Only one macro may run at a time.

To run macros 1 through 5, press the appropriate macro key. For example, to run macro 1, press [M1].

To play a macro recorded in [M1] - [M5], follow these steps:

| <b>Keystrokes:</b> | <b>Action:</b>   |
|--------------------|--|
| 1. Press [Stage].  | Selects Stage display mode   |
| 2. Press [M#].     | Macro runs; prompt shows sequence of activity as if you were entering the keystrokes |

To run any other macro, press [M\*], the number of the macro, and [Enter]. For example, to run macro 10, press [M\*] [1][0] [Enter].

To play a macro without its own key, follow these steps:

| <b>Keystrokes:</b>                        | <b>Action:</b>   |
|---|--|
| 1. Press [Stage].                         | Selects Stage display mode   |
| 2. Press [M*] and enter the macro number. | Prompt reads: <b>Select macro number, then press ENTER</b>                           |
| 3. Press [Enter].                         | Macro runs; prompt shows sequence of activity as if you were entering the keystrokes |

## Canceling a macro

To cancel a running macro, press any other macro key.

## Powerup macro

You may select a macro to run automatically each time you turn your console on. To do so, follow these steps:

| <b>Keystrokes:</b>       | <b>Action:</b>  |
|--------------------------|---|
| 1. Press [Setup].        | Selects the Setup menu  |
| 2. Press [6] [Enter].    | Selects the Options Settings menu   |
| 3. Press [1][0] [Enter]. | Selects the Powerup Macro option<br>Prompt reads: <b>Select powerup macro number (Enter 0 to disable)</b> |
| 4. Press [2][0] [Enter]. | Selects macro 20 as your powerup macro. Each time you turn on the console, macro 20 runs                  |

# Modifying macros

## Editing mode

In the Macro mode display, you can edit macros in Insert or Replace modes. In Insert mode, if you highlight a keystroke and type another keystroke, Insight 2 inserts the new keystroke before the highlighted one. In Replace mode, if you highlight a keystroke and type another keystroke, Insight 2 replaces the highlighted keystroke with the new one.

To switch from Insert mode to Replace mode, press [S2], **Replace**. To switch from Replace mode to Insert mode, press [S2], **Insert**. Insight 2 indicates the editing mode in the upper left corner of the command display.

## Editing keys

[←] and [→] move the highlight left or right when you are editing a macro.

[S3], **Delete entry**, deletes highlighted keystroke.

# Clearing macros

You must be in Macro display mode to clear individual macros. To clear all macros, you can use the Clear Macros option from the Clear Functions menu, as described on page 199.

To clear macros, follow these steps:

| <b>Keystrokes:</b>   | <b>Actions:</b>  |
|--|--|
| 1. Press [Setup].  | Selects Setup display  |
| 2. Press [8], <b>Macro Editing</b> , and press [Enter].              | Selects Macro display mode   |
| 3. Press [S6], <b>Delete Macro</b> .                                 | Prompt reads: <b>To delete macro(s), select macro number(s) and press ENTER</b><br><b>To cancel, press CLEAR</b> |
| 4. Enter macro or range of macros you want to clear.                 | Corner reads: <b>Macro 7</b>   |
| 5. Press [Enter].  | Prompt reads: <b>To confirm, press ENTER</b><br><b>To cancel, press CLEAR</b>                                    |
| 6. Press [Enter] to clear the macro or [Clear] to cancel the action. | Clears macro 7   |

## Copying macros

You may want to copy a macro or use macros as building blocks for new macros. To copy contents of one macro to another, follow these steps:

| <b>Keystrokes:</b>   | <b>Actions:</b>   |
|--|---|
| 1. Press [Setup].  | Selects Setup display   |
| 2. Press [8], <b>Macro Editing</b> , and press [Enter].          | Selects Macro display mode<br>Prompt reads: <b>Select macro number, then press ENTER</b>                                  |
| 3. Press [S7], <b>More Soft-keys</b> , [S5], <b>Copy Macro</b> . | Prompt reads:<br><b>To copy macro(s), select macro number(s) to copy and press ENTER</b><br><b>To cancel, press CLEAR</b> |
| 4. Press [2].  | Enters the number of the macro you wish to copy<br>Corner reads: <b>Macro 2</b>   |
| 5. Press [Enter].  | Prompt reads:<br><b>To copy selected macro(s), select target macro and press ENTER</b><br><b>To cancel, press CLEAR</b>   |
| 6. Press [2][5], the number of the new macro.                    | Corner reads: <b>Macro 25</b>   |
| 7. Press [Enter].  | Macro copy is complete. The contents of macro 2 have been copied into macro 25  |

*Note: In step 4, you may use [And] and [Thru] to enter multiple macros to copy. If you do, the new macros will be numbered consecutively, starting with the macro you enter in step 6.*

## Sample macros

To create these sample macros, go to Macro display mode ([Setup] [8] [Enter]), select a macro and enter the keystroke sequences as shown below. More sample macros, created by Expression style console users, are available on ETC's World Wide Web page at the following URL:

[http://www.etcconnect.com/html/service\\_macros.html](http://www.etcconnect.com/html/service_macros.html)

### Channel check

This macro brings each channel up to full for a channel check. Before you begin, you'll probably want to bring up at least one channel for working light, then clear all other channels from stage. Press [Stage] and start macro. Press macro key again to check each subsequent channel.

[At] [0] [Enter] [+] [Full]  
Macro line reads: **At 0 Enter + Full**

### Auto channel check

This macro automatically runs through each channel with a two second wait between each channel. To pause the check, press [Macro Wait]. To resume macro, press macro key again.

[At] [0] [Enter] [+] [Full] [Macro Wait] [2] [Enter] [M#]  
Macro line reads: **At 0 Enter + Full Mwait2 M#**  
(# = this macro's macro number)

### Turn off all lights except work lights

This macro captures all channels and sets them to zero. This overrides all faders and submasters. Then the macro sets work lights at full. You can easily return to previous settings by pressing [Rel] to release captured channels.

[Channel] [1] [Thru] [-] [At] [0] [Enter] [Channel] [#] [Full]  
Macro line reads: **Chan 1 Thru - At 00 Enter Chan # Full (#=work lights channel)**

### Clear faders and turn work lights on

This macro clears both faders and selects work lights.

[Clear AB] [Clear CD] [Channel] [#] [Full]  
Macro line reads: **Clear-AB Clear-CD Chan # Full**  
(#=work lights channel)

### Clear unused channels in Flexichannel mode

This macro clears channels that are visible, but no longer in use. (Because this macro uses a softkey, you must create it using Learn.)

[Setup] [1] [Enter] [S1] [Stage]  
Macro line reads: **Setup 1 Enter PurgeFlexi Stage**

### Record show on disk

This macro records the current show on disk.

[Setup] [3] [Enter] [1] [Enter] [Enter]  
Macro line reads: **Setup 3 Enter 1 Enter Enter**



# chapter 15

## diskette functions

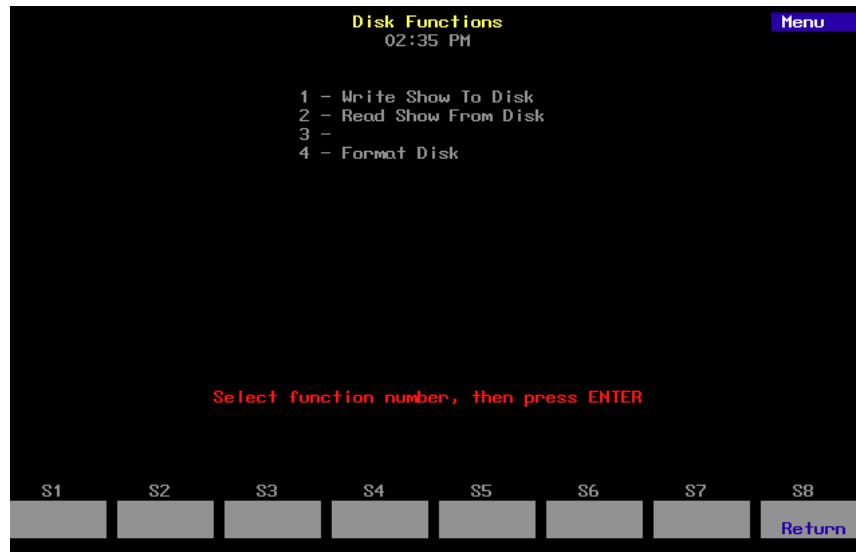

This chapter includes instructions for using Insight 2's diskette options. Insight 2 is equipped with a 3.5-inch, high density diskette drive on the console's right end panel. It allows you to save backup copies of shows on diskette. The following options are described in this chapter:

- Formatting diskettes
- Recording a show on diskette
- Reading a show from diskette

## ***Diskette management***

Insight 2's diskette drive lets you save one show per high density 3.5-inch computer diskette. This allows you to work on more than one show at a time or to use more than 600 cues for your production by loading a second show into memory.

Label each diskette carefully and clearly to help you keep track of what show is on the diskette. You can also use the Read Show from Disk option to find out the name, storage date and time of the show on any diskette.

*Note: For information on naming a show in the Setup menu, see page 27.*

We recommend that you make two back-up copies of each show on separate diskettes and that you keep them in different locations. If your show diskette were damaged, a back-up diskette stored at home could save you hours of work.

When you select diskette options, any fades in progress are stopped. Therefore, if you need to load an additional show in the middle of a performance, load it between cues when all channels are static. Fader and sub-master outputs are maintained as the new show loads.

Before you can use a diskette in Insight 2, you must format it on the console or on an IBM PC-compatible with a high-density drive. Formatting instructions are on the following page.

### ***Storing diskettes***

- Store diskettes at a temperature between 50 and 140 degrees Fahrenheit.
- Keep diskettes away from magnets, magnetized objects or heavy electrical equipment, including large lighting equipment.
- Do not touch the magnetic disk inside the plastic diskette case.
- Do not eat, drink or smoke when you handle diskettes.

# Formatting diskettes

*Warning: Formatting a diskette erases all information recorded on the diskette. Formatting does not affect show in console.*

Before you can use a diskette in an Insight 2, you must format it on either an Expression 2 line console or a standard PC-compatible personal computer. To format a diskette on Insight 2, follow these steps:

- | <b>Keystrokes:</b>  | <b>Action:</b>                  |
|---|---------------------------------|
| 1. Press [Setup].   | Selects Setup display           |
| 2. Press [3], <b>Disk Functions</b> , [Enter].                    | Selects Diskette Functions menu |
| 3. Insert standard 3.5-inch, high-density diskette in disk drive. |                                 |
| 4. Press [4], <b>Format Disk</b> , [Enter].                       | The following screen appears:   |



- |   |   |
|---|---|
| 5. Press [Enter] to format the diskette, or press [Clear] to cancel the format command. | Message appears on screen: <b>Formatting disk - Do not remove from drive.</b> Message remains until disk is formatted |
|---|---|

*Warning: When you select this option, any fade in progress stops; once the formatting process is complete, the fade jumps to the point it would have reached if it hadn't been interrupted.*

## Recording a show on diskette

When you record a show to diskette, all system settings, patch settings, cues, groups, submasters, effects, and any other information that you have in the console at the time you record the show, are saved. We recommend that you keep at least two backup copies of each show on diskette.

When using the record option, any fades being executed are interrupted during the record operation; fades resume when record is complete. To record a show from memory to a diskette follow these steps:

- | Keystrokes:  | Action:                         |
|--|---------------------------------|
| 1. Insert a formatted diskette in disk drive.      |                                 |
| 2. Press [Setup].                                  | Selects Setup display           |
| 3. Press [3], <b>Disk Functions</b> , [Enter].     | Selects Diskette Functions menu |
| 4. Press [1], <b>Write Show to Disk</b> , [Enter]. | The following screen appears:   |



- |   |  |
|---|--|
| 5. Press [Enter], or press [Clear] to cancel the operation. | Message appears on screen: <b>To disk in progress</b> . Message remains until show is recorded |
|---|--|

## Reading a show from diskette

When you read a show and system settings from a diskette and load it into memory, the new show completely overwrites the current show, including channel and dimmer counts and default times and level. Therefore, if you want to keep the current show, follow the instructions on page 180 to record current show before you read a new show from diskette. If your Designer's Worksheet setup is different in the new show, a message will warn you.

Fades being executed are interrupted during the read operation; fades resume when read is complete. To read all information from diskette into memory follow these steps:

| Keystrokes:   | Action:  |
|---|--|
| 1. Insert diskette in disk drive.                   |  |
| 2. Press [Setup].                                   | Selects Setup display  |
| 3. Press [3], <b>Disk Functions</b> , [Enter].      | Selects Diskette Functions menu  |
| 4. Press [2], <b>Read Show from Disk</b> , [Enter]. | The following screen appears. Show information is displayed, including show name, date recorded, etc |

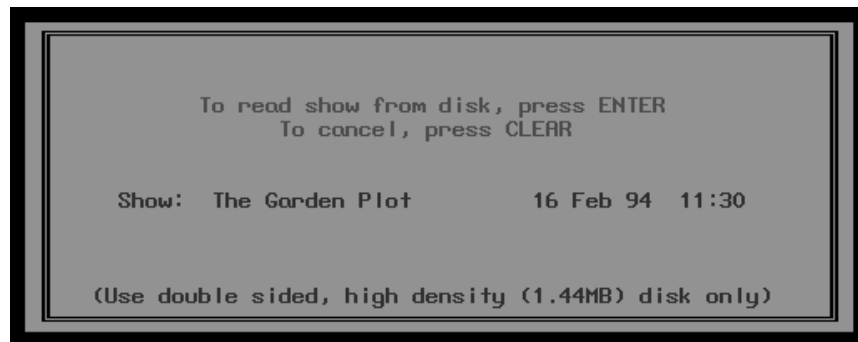

|   |  |
|---|--|
| 5. Press [Enter], or press [Clear] to cancel the operation. | Message appears on screen: <b>From disk in progress</b> . Message remains until show is loaded |
|---|--|



# chapter 16

## printing

Insight 2 supports parallel printers, including some laser printers. Printer installation is described on page 283 of *Appendix A, Installation*. This chapter includes instructions for using Insight 2's print options. Each of the following printouts is explained and illustrated on the following pages.

- Stage display
- Cues
- Groups
- Submasters
- Cue list
- Group list
- Submaster list
- Macros
- Patch
- Channel attributes
- Real Time Programs
- SMPTE events
- Tracksheet

## Printer options

Before you begin printing, verify that your printer is installed correctly and that it is turned on. For instructions on installing printers, see *Appendix A, Installation*.

All print options are located on the Print Functions menu. To display the menu press [Setup], then select [5], **Print Functions**, and press [Enter]. Insight 2 displays the Print Functions menu illustrated below.



You may pause the current printing job or cancel it at any time while printing. To stop the printer temporarily while it is printing, press [S2], **Pause Printer**. The printer prints a few more lines, then stops and waits. Press [S2] again to resume printing. To cancel a print job, press [S1], **Stop Printer**. The printer prints a few more lines, then stops.

## Stage display

Print Stage display prints channel settings as they currently appear on Stage. To print a Stage display report, follow these steps:

- | Keystrokes:   | Action:  |
|---|--|
| 1. Press [Setup].   | Displays Setup menu  |
| 2. Press [5], <b>Print Functions</b> , [Enter].                   | Displays Print Functions menu  |
| 3. Press [1], <b>Print Stage Display</b> , [Enter].               | Prompt reads:<br><b>To confirm, press ENTER</b><br><b>To cancel, press CLEAR</b> |
| 4. Press [Enter], or press [Clear] to cancel the print operation. | File sent to the printer   |

# Cues

Print Cues prints a list of cues recorded in the currently loaded show. Cues are listed by number. Information provided includes all cue attributes and levels of all channels included in each cue. To print a full list of cues, follow these steps:

| <b>Keystrokes:</b>  | <b>Action:</b>   |
|---|--|
| 1. Press [Setup].   | Displays Setup menu  |
| 2. Press [5], <b>Print Functions</b> , [Enter].                   | Displays Print Functions menu  |
| 3. Press [2], <b>Print Cues</b> , [Enter].                        | Prompt reads:<br><b>Press ENTER to print all cues, or select 1st cue number to print</b> |
| 4. Press [Enter].   | Prompt reads:<br><b>To confirm, press ENTER</b><br><b>To cancel, press CLEAR</b>         |
| 5. Press [Enter], or press [Clear] to cancel the print operation. | File sent to the printer   |

To print a partial list of cues from the Print menu, follow these steps:

| <b>Keystrokes:</b>  | <b>Action:</b>   |
|---|--|
| 1. Press [2], <b>Print Cues</b> , [Enter].  | Prompt reads:<br><b>Press ENTER to print all cues, or select 1st cue number to print</b> |
| 2. Use the keypad to enter the first cue in the range you wish to print. Press [Enter]. | Prompt reads:<br><b>Press ENTER to print cue, or select last cue number to print</b>     |
| 3. Use the keypad to enter the last cue in the range you wish to print. Press [Enter].  | File sent to the printer   |

# Groups

Print Groups prints a list of groups recorded in the currently loaded show. Groups are listed by number. Information provided includes the group's label and the levels of all channels included in each group.

To print a full list of groups, follow these steps:

| <b>Keystrokes:</b>  | <b>Action:</b>   |
|---|--|
| 1. Press [Setup].   | Displays Setup menu  |
| 2. Press [5], <b>Print Functions</b> , [Enter].                   | Displays Print Functions menu  |
| 3. Press [3], <b>Print Groups</b> , [Enter].                      | Prompt reads:<br><b>Press ENTER to print all groups, or select 1st group number to print</b> |
| 4. Press [Enter].   | Prompt reads:<br><b>To confirm, press ENTER</b><br><b>To cancel, press CLEAR</b>             |
| 5. Press [Enter], or press [Clear] to cancel the print operation. | File sent to the printer   |

To print a partial group printout from the Print menu, follow these steps:

| <b>Keystrokes:</b>  | <b>Action:</b>   |
|---|--|
| 1. Press [3], <b>Print Groups</b> , [Enter].  | Prompt reads:<br><b>Press ENTER to print all cues, or select 1st cue number to print</b> |
| 2. Use the keypad to enter the first group in the range you wish to print. Press [Enter]. | Prompt reads:<br><b>Press ENTER to print cue, or select last cue number to print</b>     |
| 3. Use the keypad to enter the last group in the range you wish to print. Press [Enter].  | File sent to the printer   |

# Submasters

Print Submasters prints full information about all 1,080 submaster memories. Submasters are listed by number. Upfade, dwell and downfade times, and rates and labels are included in the printout. Levels of all channels included in each submaster are also provided. To print a full list of submasters, follow these steps:

| <b>Keystrokes:</b>                               | <b>Action:</b>   |
|--|--|
| 1. Press [Setup].                                | Displays Setup menu  |
| 2. Press [5], <b>Print Functions</b> , [Enter].  | Displays Print menu  |
| 3. Press [4], <b>Print Submasters</b> , [Enter]. | Prompt reads:<br><b>Press ENTER to print all submasters, or press PAGE to select submasters to print</b> |
| 4. Press [Enter].                                | File sent to the printer   |

To print a partial submaster list, follow these steps:

| <b>Keystrokes:</b>   | <b>Action:</b>   |
|--|--|
| 1. Press [4], <b>Print Submasters</b> , [Enter].                                     | Prompt reads:<br><b>Press ENTER to print all submasters, or press PAGE to select submasters to print</b>         |
| 2. Press [Page].   | Prompt reads:<br><b>Select submaster page to print, then press ENTER (1 = Page 1, 2 = Page 2, 0 = All pages)</b> |
| 3. Press [0], [1] or [2], then press [Enter].  | Prompt reads:<br><b>Press ENTER to print all submasters, or select 1st submaster to print</b>                    |
| 4. Use the keypad to enter the first submaster in the range to print. Press [Enter]. | Prompt reads:<br><b>Press ENTER to print submaster, or select last submaster to print</b>                        |
| 5. Use the keypad to enter the last submaster in the range to print. Press [Enter].  | File sent to the printer   |

## Cue List

Cue List prints a list of cues recorded in the currently loaded show as well as all cue attributes. Cues are listed by number. To print a full cue list printout, follow these steps:

| <b>Keystrokes:</b>  | <b>Action:</b>   |
|---|--|
| 1. Press [Setup].   | Displays Setup menu  |
| 2. Press [5], <b>Print Functions</b> , [Enter].                   | Displays Print Functions menu  |
| 3. Press [5], <b>Print Cue List</b> , [Enter].                    | Prompt reads:<br><b>To confirm, press ENTER</b><br><b>To cancel, press CLEAR</b> |
| 4. Press [Enter], or press [Clear] to cancel the print operation. | File sent to the printer   |

## Group List

Print Group List prints a list of groups recorded in the currently loaded show. Groups are listed by number. Information provided includes each group's label.

To print a full group list printout, follow these steps:

| <b>Keystrokes:</b>  | <b>Action:</b>   |
|---|--|
| 1. Press [Setup].   | Displays Setup menu  |
| 2. Press [5], <b>Print Functions</b> , [Enter].                   | Displays Print Functions menu  |
| 3. Press [6], <b>Print Group List</b> , [Enter].                  | Prompt reads:<br><b>To confirm, press ENTER</b><br><b>To cancel, press CLEAR</b> |
| 4. Press [Enter], or press [Clear] to cancel the print operation. | File sent to the printer   |

## ***Submaster List***

Print Submaster List prints full information about all 1,080 submaster memories. Submasters are listed by number. Upfade, dwell and downfade times, and rates and labels are included in the printout.

To print a full submaster list printout, follow these steps:

| <b>Keystrokes:</b>  | <b>Action:</b>   |
|---|--|
| 1. Press [Setup].   | Displays Setup menu  |
| 2. Press [5], <b>Print Functions</b> , [Enter].                   | Displays Print Functions menu  |
| 3. Press [7], <b>Print Submaster List</b> , [Enter].              | Prompt reads:<br><b>To confirm, press ENTER</b><br><b>To cancel, press CLEAR</b> |
| 4. Press [Enter], or press [Clear] to cancel the print operation. | File sent to the printer   |

# Macros

Print Macros prints a list of macro sequences recorded in the currently loaded show. Macros are listed by number. The printout provides complete information about each macro and its keystrokes.

To print a full macro list, follow these steps:

| <b>Keystrokes:</b>  | <b>Action:</b>   |
|---|--|
| 1. Press [Setup].   | Displays Setup menu  |
| 2. Press [5], <b>Print Functions</b> , [Enter].                   | Displays Print Functions menu  |
| 3. Press [8], <b>Print Macros</b> , [Enter].                      | Prompt reads:<br><b>Press ENTER to print all macros, or select 1st macro number to print</b> |
| 4. Press [Enter].   | Prompt reads:<br><b>To confirm, press ENTER<br/>To cancel, press CLEAR</b>                   |
| 5. Press [Enter], or press [Clear] to cancel the print operation. | File sent to the printer   |

To print a partial macro list from the Print menu, follow these steps:

| <b>Keystrokes:</b>  | <b>Action:</b>   |
|---|--|
| 1. Press [8], <b>Print Macros</b> , [Enter].  | Prompt reads:<br><b>Press ENTER to print all macros, or select 1st macro number to print</b> |
| 2. Use the keypad to enter the first macro in the range you wish to print. Press [Enter]. | Prompt reads:<br><b>Press ENTER to print macro, or select last macro number to print</b>     |
| 3. Use the keypad to enter the last macro in the range you wish to print. Press [Enter].  | File sent to the printer   |

## ***Patch***

Print Patch prints the current dimmer-to-channel patch. To print a full patch report, follow these steps:

| <b>Keystrokes:</b>  | <b>Action:</b>   |
|---|--|
| 1. Press [Setup].   | Displays Setup menu  |
| 2. Press [5], <b>Print Functions</b> , [Enter].                   | Displays Print Functions menu  |
| 3. Press [9], <b>Print Patch</b> , [Enter].                       | Prompt reads:<br><b>To confirm, press ENTER</b><br><b>To cancel, press CLEAR</b> |
| 4. Press [Enter], or press [Clear] to cancel the print operation. | File sent to the printer   |

## ***Channel Attributes***

Print Channel Attributes prints a list of channel attributes recorded in the currently loaded show.

To print a full list of channel attributes, follow these steps:

| <b>Keystrokes:</b>  | <b>Action:</b>   |
|---|--|
| 1. Press [Setup].   | Displays Setup menu  |
| 2. Press [5], <b>Print Functions</b> , [Enter].                   | Displays Print Functions menu  |
| 3. Press [1][1], <b>Print Channel Attributes</b> , [Enter].       | Prompt reads:<br><b>To confirm, press ENTER</b><br><b>To cancel, press CLEAR</b> |
| 4. Press [Enter], or press [Clear] to cancel the print operation. | File sent to the printer   |

## ***Real Time Programs***

Print Real Time Programs prints a list of programs recorded in the currently loaded show. The printout provides complete information about the programs.

To print a full list of programs, follow these steps:

| <b>Keystrokes:</b>  | <b>Action:</b>   |
|---|--|
| 1. Press [Setup].   | Displays Setup menu  |
| 2. Press [5], <b>Print Functions</b> , [Enter].                   | Displays Print Functions menu  |
| 3. Press [1][2], <b>Print Real Time Programs</b> , [Enter].       | Prompt reads:<br><b>Press ENTER to print all program events, or select first program number to print</b> |
| 4. Press [Enter], or press [Clear] to cancel the print operation. | File sent to the printer   |

## ***SMPTE events***

Print SMPTE Events prints a list of events recorded in the currently loaded show. The printout provides complete information about the events.

To print a full SMPTE program, follow these steps:

| <b>Keystrokes:</b>  | <b>Action:</b>   |
|---|--|
| 1. Press [Setup].   | Displays Setup menu  |
| 2. Press [5], <b>Print Functions</b> , [Enter].                   | Displays Print Functions menu  |
| 3. Press [1][3], <b>Print SMPTE Events</b> , [Enter].             | Prompt reads:<br><b>Press ENTER to print all SMPTE events, or select first event number to print</b> |
| 4. Press [Enter], or press [Clear] to cancel the print operation. | File sent to the printer   |

# Tracksheet

Print Tracksheet lists channel tracking information from your Tracksheet. To print a track for any channel, follow these steps:

| <b>Keystrokes:</b>                                  | <b>Action:</b>   |
|---|--|
| 1. Press [Setup].                                   | Displays Setup menu  |
| 2. Press [5], <b>Print Functions</b> , [Enter].     | Displays Print Functions menu  |
| 3. Press [1][4], <b>Print Tracksheet</b> , [Enter]. | Prompt reads:<br><b>Select channel number to track, then press ENTER</b> |
| 4. Enter channel number, then press [Enter].        | File sent to the printer   |



# *chapter 17*

## *clear functions*

This chapter includes instructions for using Insight 2's clear options. Each of the following clear functions is explained and illustrated on the following pages.

- Show
- Cues
- Groups
- Submasters
- Show and patch
- Designer's Worksheet
- Macros
- Reset patch
- Channel attributes
- Real Time Programs
- SMPTE events
- Reset system

## Clear functions

Each option on the Clear Functions menu erases information regarding an Insight 2 function from the console's memory. If that information is saved in a show on a diskette, it can be restored to the console. Otherwise, the information is lost permanently.

*Warning: Be certain to save your shows on disk before erasing information you may need in the future. See Chapter 16, Diskette functions, for information about saving shows.*

All clear options are located on the Clear Functions menu. To display the menu, press [Setup], then select [4], **Clear Functions**, and press [Enter]. Insight 2 displays the Clear Functions menu illustrated below.



## Show

Clear Show erases all information associated with a specific show from your console's memory. This does not include patch information or system configuration information.

To erase a full show, follow these steps:

| <b>Keystrokes:</b>                              | <b>Action:</b>   |
|---|--|
| 1. Press [Setup].                               | Displays Setup menu  |
| 2. Press [4], <b>Clear Functions</b> , [Enter]. | Displays Clear Functions menu<br>Prompt reads: <b>Select function number, then press ENTER</b> |
| 3. Press [1], <b>Clear Show</b> , [Enter].      | Prompt reads:<br><b>To clear show data, press ENTER</b><br><b>To cancel, press CLEAR</b>       |
| 4. Press [Enter].                               | Show cleared. Returns to Stage display mode  |

## Cues

Clear Cues erases all recorded cues from a show.

To erase all cues, follow these steps:

| <b>Keystrokes:</b>                              | <b>Action:</b>   |
|---|--|
| 1. Press [Setup].                               | Displays Setup menu  |
| 2. Press [4], <b>Clear Functions</b> , [Enter]. | Displays Clear Functions menu<br>Prompt reads: <b>Select function number, then press ENTER</b> |
| 3. Press [2], <b>Clear Cues</b> , [Enter].      | Prompt reads:<br><b>To clear cues, press ENTER</b><br><b>To cancel, press CLEAR</b>            |
| 4. Press [Enter].                               | Cues cleared. Returns to Setup menu  |

## Groups

Clear Groups erases all recorded groups from a show.

To erase all groups, follow these steps:

| <b>Keystrokes:</b>                              | <b>Action:</b>   |
|---|--|
| 1. Press [Setup].                               | Displays Setup menu  |
| 2. Press [4], <b>Clear Functions</b> , [Enter]. | Displays Clear Functions menu<br>Prompt reads: <b>Select function number, then press ENTER</b> |
| 3. Press [3], <b>Clear Groups</b> , [Enter].    | Prompt reads:<br><b>To clear groups, press ENTER</b><br><b>To cancel, press CLEAR</b>          |
| 4. Press [Enter].                               | Groups cleared. Returns to Setup menu  |

## Submasters

Clear Submasters erases all recorded submasters from a show.

To erase all submasters, follow these steps:

| <b>Keystrokes:</b>                              | <b>Action:</b>   |
|---|--|
| 1. Press [Setup].                               | Displays Setup menu  |
| 2. Press [4], <b>Clear Functions</b> , [Enter]. | Displays Clear Functions menu<br>Prompt reads: <b>Select function number, then press ENTER</b> |
| 3. Press [4], <b>Clear Submasters</b> .         | Prompt reads:<br><b>To clear submasters, select page and press ENTER (0 = All pages)</b>       |
| 4. Press [Enter].                               | Submasters cleared. Returns to Setup menu  |

## Show and Patch

Clear Show and Patch erases all information associated with a specific show from your console's memory, including patch information and system configuration information.

To erase a full show and patch, follow these steps:

| <b>Keystrokes:</b>                                   | <b>Action:</b>   |
|--|--|
| 1. Press [Setup].                                    | Displays Setup menu  |
| 2. Press [4], <b>Clear Functions</b> , [Enter].      | Displays Clear Functions menu<br>Prompt reads: <b>Select function number, then press ENTER</b> |
| 3. Press [5], <b>Clear Show and Patch</b> , [Enter]. | Prompt reads: <b>To clear show and patch, press ENTER</b><br><b>To cancel, press CLEAR</b>     |
| 4. Press [Enter].                                    | Show cleared. Returns to Stage display mode  |

# Designer's Worksheet

Designer's Worksheet erases all regions from the Designer's Worksheet layout. Macros assigned to the regions are not erased.

To erase all regions, follow these steps:

| <b>Keystrokes:</b>   | <b>Action:</b>  |
|--|---|
| 1. Press [Setup].  | Displays Setup menu   |
| 2. Press [4], <b>Clear Functions</b> , [Enter].            | Displays Clear Functions menu<br>Prompt reads: <b>Select function number, then press ENTER</b>      |
| 3. Press [7], <b>Clear Designer's Worksheet</b> , [Enter]. | Prompt reads:<br><b>To clear Designer's Worksheet, press ENTER</b><br><b>To cancel, press CLEAR</b> |
| 4. Press [Enter].  | Designer's Worksheet regions cleared. Returns to Setup menu   |

# Macros

Clear Macros erases all macro information from a show.

To erase all macros, follow these steps:

| <b>Keystrokes:</b>                              | <b>Action:</b>   |
|---|--|
| 1. Press [Setup].                               | Displays Setup menu  |
| 2. Press [4], <b>Clear Functions</b> , [Enter]. | Displays Clear Functions menu<br>Prompt reads: <b>Select function number, then press ENTER</b> |
| 3. Press [8], <b>Clear Macros</b> , [Enter].    | Prompt reads:<br><b>To clear macros, press ENTER</b><br><b>To cancel, press CLEAR</b>          |
| 4. Press [Enter].                               | Macros cleared<br>Returns to Setup menu  |

## Reset 1-to-1 Patch

Reset Patch 1-to-1 resets your console's patch to a one-to-one, patch. Thus, channel 1 is patched to dimmer 1, channel 2 is patched to dimmer 2, and so on. This function is independent of your show. It does not clear label, level or profile settings. See *Chapter 5, Patch*, for more information about patch.

To clear all patch information, including label, level and profile settings, press [Setup] [4] [Enter] and select Clear Show and Patch or press [S1], **Reset System**.

To reset your patch, follow these steps:

| <b>Keystrokes:</b>                                 | <b>Action:</b>   |
|--|--|
| 1. Press [Setup].                                  | Displays Setup menu  |
| 2. Press [4], <b>Clear Functions</b> , [Enter].    | Displays Clear Functions menu  |
| 3. Press [9], <b>Reset Patch 1-to-1</b> , [Enter]. | Prompt reads:<br><b>To reset patch, press ENTER</b><br><b>To cancel, press CLEAR</b> |
| 4. Press [Enter].                                  | Patch is reset. Returns to Setup menu  |

## Channel Attributes

Clear Channel Attributes erases all channel attribute information from a show.

To erase all channel attribute information, follow these steps:

| <b>Keystrokes:</b>   | <b>Action:</b>  |
|--|---|
| 1. Press [Setup].  | Displays Setup menu   |
| 2. Press [4], <b>Clear Functions</b> , [Enter].            | Displays Clear Functions menu<br>Prompt reads: <b>Select function number, then press ENTER</b>    |
| 3. Press [1][1], <b>Clear Channel Attribute</b> , [Enter]. | Prompt reads:<br><b>To clear channel attributes, press ENTER</b><br><b>To cancel, press CLEAR</b> |
| 4. Press [Enter].  | Channel attribute settings are cleared.<br>Returns to Setup menu                                  |

# Real Time Programs

Clear Real Time Programs erases all program information from a show.

To erase all programs, follow these steps:

| <b>Keystrokes:</b>  | <b>Action:</b>  |
|---|---|
| 1. Press [Setup].   | Displays Setup menu   |
| 2. Press [4], <b>Clear Functions</b> , [Enter].             | Displays Clear Functions menu<br>Prompt reads: <b>Select function number, then press ENTER</b>              |
| 3. Press [1][2], <b>Clear Real Time Programs</b> , [Enter]. | Prompt reads:<br><b>To clear all real time clock programs, press ENTER</b><br><b>To cancel, press CLEAR</b> |
| 4. Press [Enter].   | Programs cleared. Returns to Setup menu.  |

# SMPTE

Clear SMPTE Events erases all SMPTE information from a show.

To erase all SMPTE events, follow these steps:

| <b>Keystrokes:</b>                                    | <b>Action:</b>  |
|---|---|
| 1. Press [Setup].                                     | Displays Setup menu   |
| 2. Press [4], <b>Clear Functions</b> , [Enter].       | Displays Clear Functions menu<br>Prompt reads: <b>Select function number, then press ENTER</b>  |
| 3. Press [1][3], <b>Clear SMPTE Events</b> , [Enter]. | Prompt reads:<br><b>To clear all SMPTE events, press ENTER</b><br><b>To cancel, press CLEAR</b> |
| 4. Press [Enter].                                     | SMPTE events cleared.<br>Returns to Setup menu.   |

## ***Reset system***

Reset System erases all show information from the console, resets your patch, and resets all configuration information to factory defaults.

To reset Insight 2, follow these steps:

| <b>Keystrokes:</b>                              | <b>Action:</b>  |
|---|---|
| 1. Press [Setup].                               | Displays Setup menu   |
| 2. Press [4], <b>Clear Functions</b> , [Enter]. | Displays Clear Functions menu<br>Prompt reads: <b>Select function number, then press ENTER</b>                    |
| 3. Press [S1], <b>Reset System</b> .            | Prompt reads: <b>To clear entire system and reset to default settings, press ENTER<br/>To cancel, press CLEAR</b> |
| 4. Press [Enter].                               | System resets and returns to Stage mode display   |

# chapter 18

## accessories

This chapter includes instructions for working with the following Insight 2 accessories:

- Remote Focus Unit (RFU)
- Infrared Remote Focus Unit (IRFU)
- Designer's Worksheet
- Alphanumeric keyboard

For accessory installation instructions, see *Appendix A, Installation*. For purchase information, please contact your local dealer or ETC.

# Remote Focus Unit (RFU)

The Remote Focus Unit (RFU) is a small, portable control panel you can use from a remote location, such as in the house, on your studio set or from backstage. You can use an RFU with or without a remote monitor.

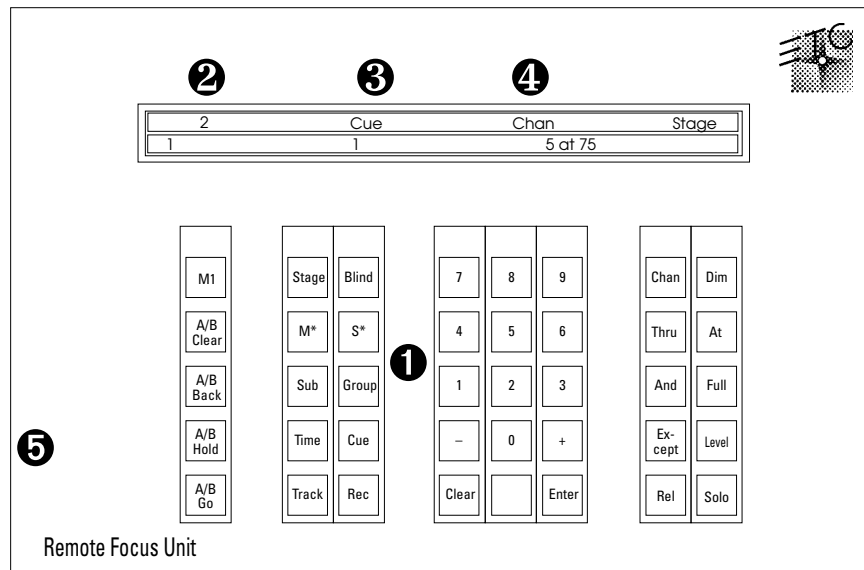

## ① Keypad

The keys on the RFU's keypad function exactly like their counterparts on the console.

## ② Fader window

The top line displays the next cue on the cue list. The bottom line displays the cue in the A/B fader on the left and the cue in the C/D fader on the right.

## ③ Cue/channel number window

Displays the currently selected cue, group or submaster

## ④ Keypad prompt window

Displays the same prompt that appears in the upper right corner of the Stage or Blind display.

## ⑤ Power switch

Power switch is on in the up position and off in the down position.

For RFU installation instructions see *Appendix A, Installation*. RFU must be turned **Off** before you install it. For instruction on installing a remote monitor, see *Installing remote video monitors* on page 300.

To operate your installed RFU, move power switch to **On**.

The console keypad and RFU are able to operate simultaneously. Changes made from both console and RFU are displayed immediately on both console monitor and RFU.

You can control most console functions with RFU; you cannot control submasters, however.

*Warning: Do not connect or disconnect the RFU when it is turned on.*

# Infrared Remote Focus Unit (IRFU)

The Infrared Remote Focus Unit (IRFU) allows you to control the Insight 2 console from distances up to 50 meters. With it you can play back cues and macros, and access dimmers, channels, groups, and cues. The IRFU can also be wired to the main control console. To enable the IRFU in Insight 2, ETC must modify the console at the factory and setup options must be adjusted. See *Installing Infrared Remote Focus Unit* on page 301 for more information.

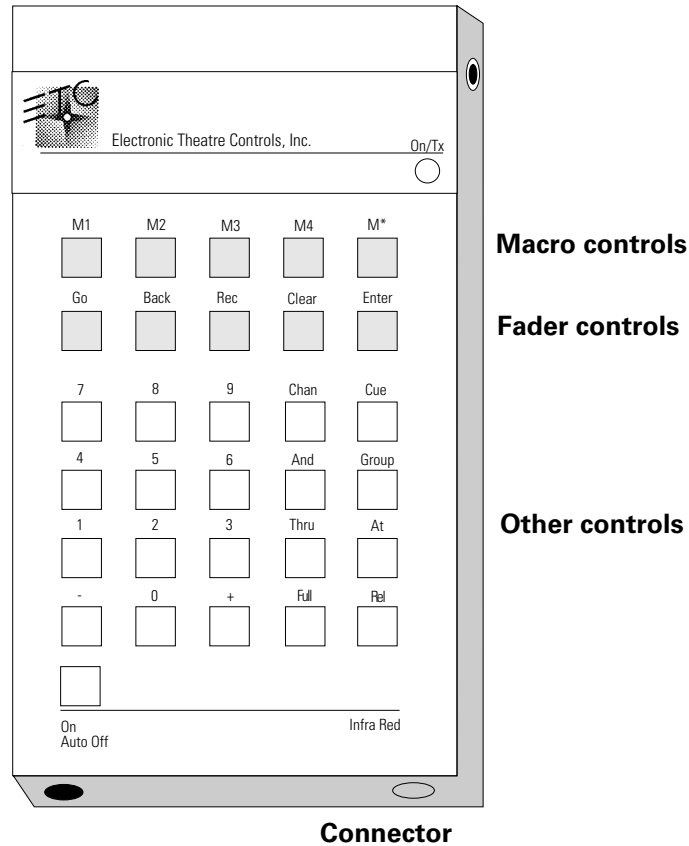

### **Macro controls**

The five macro keys allow you to access macros. M1, M2, M3, and M4 allow you to access macros 1,951 through 1,954. M\* allows you to enter any other macro. To access other macros, press [M\*], enter the desired macro number, and press [Enter].

### **Fader controls**

The fader control keys allow you to play back cues in the console's cross-faders. [Go] controls the AB fader pair; the remaining keys function as on the console keypad.

### **Other controls**

The remaining controls enable you to select dimmers, channels, groups, and cues. Keys function as they do on the console keypad.

### **Connector**

Connector for hard wire connection to receiving unit.

Press [On] key on the infrared controller to turn power on. The unit shuts off after three minutes if no key is pressed. The unit is powered by a 9V, size PP3 battery.

Console controls and the infrared controller may operate simultaneously. Changes made from both console and infrared controller are displayed immediately on the console monitor.

# Designer's Worksheet

Designer's Worksheet gives you control of the console from remote locations such as in the house, on the set, or backstage. The Designer's Worksheet is a digitizer tablet that emulates the console face panel and provides user-definable regions. All functions may be selected using the stylus supplied with the Designer's Worksheet.

If you have not yet installed your Designer's Worksheet, see *Appendix A, Installation*.

Three digitizer templates are available. The correct template for your worksheet depends on your digitizer's size. Each digitizer allows you to program up to 2,000 regions, each of which may be associated with a macro.

## **12 x 12 inch digitizer**

If you own a 12 x 12 inch digitizer, you can select one of two digitizer layouts. One layout provides control of submasters and faders, while the other deletes the submasters for increased workspace area.

## **12 x 17 inch digitizer tablet**

The 12 x 17 layout provides control of fader keys and all console functions other than submasters, fader sliders, and the Grandmaster slider.

*Note: You may control submaster sliders from either the console or the digitizer, but not both. Use the Designer's Worksheet Setup display to select this option. See Setting Designer's Worksheet options on page 20 for information on the Designer's Worksheet Setup display.*

## **Using the Designer's Worksheet**

To use the Designer's Worksheet to control console keys, touch the corresponding area on the worksheet with the stylus. To use submaster sliders or the wheels, drag the stylus along the corresponding control strip.

The remaining area of the tablet is available for user-definable regions. To each of these regions you may assign a macro containing a sequence of up to 50 console keystrokes. Each region's macro can execute cues, manipulate channel levels or execute any series of keystrokes. Once you assign a macro to a region, start the macro by touching the region on the tablet.

For example, you might draw a picture of the stage and outline regions corresponding to various instruments or fixtures on stage or in a studio. You might program each region to select the channels for that area of the stage. You can then touch that region to select channels, and then enter desired level.

Or, you might program more abstract regions on the worksheet. For example, you might program several areas on the worksheet, each representing a song in a band's play list.

## Programming regions

Before you begin programming, design your worksheet regions by drawing them on the worksheet tablet provided. Be certain that the tablet has been calibrated. See *Appendix A, Installation*, for details on calibrating the tablet. Place your drawing under the clear plastic cover sheet, and you're ready to start.

To create new or edit existing regions and macros, follow these steps:

### Keystrokes:

1. Turn Designer's Worksheet on.
2. With the worksheet pen, touch [Setup].
3. Select 7, **Designer's Worksheet Editing**, and touch [Enter].

### Actions:

Selects Setup display

Prompt reads:

**Select region number or touch a previously defined region, then touch ENTER**

Insight 2 displays the following screen

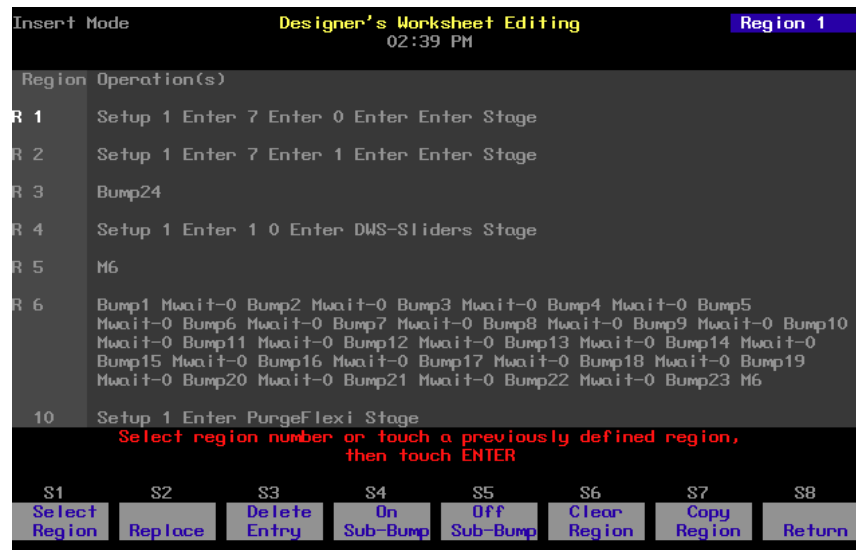

4. Enter the new region number, or select an existing region, either by touching the region or by entering its number from the keypad.
5. Touch [Enter].
6. To create a new region or to add to an existing region, trace the area you want to define for that region number, then press [Enter]. To keep an existing region, touch [Enter].

Prompt reads: **Outline region or touch ENTER to continue**

The console displays a highlighted **R** next to the macro number to indicate that it has been assigned to a region  
Prompt reads:

**Select operations for this region  
Touch ENTER MACRO when done**

7. Touch desired keystrokes to create a new macro assigned to the new region. As you touch keys on the worksheet or console, they are displayed on the editing screen
8. Use the arrow keys to edit macros, if necessary. Macro editing is described in greater detail in *Chapter 15, Working with macros*.
9. Press or touch [Enter Macro] to save the macro. Each macro has a 50 keystroke limit. Prompt reads: **Select region number or touch a previously defined region, then touch ENTER**
10. Enter another macro or edit an existing macro by following steps 4 through 9. Or, return to another mode by touching the appropriate key.

*Hint: If you need to exceed the 50 keystroke limit, link another macro to the end by entering its number as the last keystroke, then enter the rest of your commands in the linked macro.*

## **Macro Wait**

To program a pause in the macro, press [Macro wait]. Insight 2 displays **Mwait-0**. Enter the length of the pause in minutes and seconds, or as a fraction of a second in decimal form from .1 second to 99:59 minutes.

## Copying regions

You may want to copy a region or use regions as building blocks for new regions. To copy contents of one region to another, follow these steps:

| Keystrokes:  | Actions:  |
|--|---|
| 1. Press [Setup].  | Selects Setup display   |
| 2. Press [7], <b>Designer Worksheet Editing</b> , and press [Enter]. | Selects Macro display mode<br>Prompt reads:<br><b>Select region number or touch a previously defined region, then touch ENTER</b> |
| 3. Press [S7], <b>Copy Region</b> .                                  | Prompt reads:<br><b>To copy region(s), select region number(s) to copy and touch ENTER</b><br><b>To cancel, touch CLEAR</b>       |
| 4. Press [2] [Enter].  | Prompt reads:<br><b>To copy selected region(s), select target region and touch ENTER</b><br><b>To cancel, touch CLEAR</b>         |
| 5. Press [Enter].  | Prompt reads:<br><b>To copy selected macro(s), select target macro and press ENTER</b><br><b>To cancel, press CLEAR</b>           |
| 6. Press [2][5], the number of the new region.                       | Corner reads: <b>Region 25</b>  |
| 7. Press [Enter].  | Region copy is complete. The contents of region 2 have been copied into region 25   |

*Note: In step 4, you may use [And] and [Thru] to enter multiple regions to copy. If you do, the new regions will be numbered consecutively, starting with the region you enter in step 6.*

## Clearing regions

You must be in Designer's Worksheet Editing display mode to clear individual regions. To clear all regions, you can use the Clear Designer's Worksheet option from the Clear Functions menu, as described on page 199.

*Note: Clearing regions does not affect the macro assigned to the region. Clearing a region removes it from the digitizer and the Designer's Worksheet display, and removes the macro assignment.*

To clear regions, follow these steps:

| <b>Keystrokes:</b>   | <b>Actions:</b>  |
|--|--|
| 1. Press [Setup].  | Selects Setup display  |
| 2. Press [7], <b>Designer's Worksheet Editing</b> , and press [Enter]. | Selects Designer's Worksheet Editing display mode  |
| 3. Press [S6], <b>Clear Region</b> .                                   | Prompt reads:<br><b>To clear region(s), select region number(s) and touch ENTER</b><br><b>To cancel, touch CLEAR</b> |
| 4. Press [7].  | Selects region 7 to clear<br>Corner reads:<br><b>Region 7</b>  |
| 5. Press [Enter].  | Prompt reads:<br><b>To confirm, touch ENTER</b><br><b>To cancel, touch CLEAR</b>                                     |
| 6. Press [Enter] to clear the region or [Clear] to cancel the action.  | Clears region 7 from the Designer's Worksheet layout; removes the assignment of macro 7 to region 7                  |

## Alphanumeric keyboard

Insight 2 supports a standard alphanumeric keyboard. The keyboard allows you to assign names to cues, dimmers, submasters, groups and shows.

See *Installing an alphanumeric keyboard* on page 282 for installation information.

### ***Naming cues, submasters, groups, and shows***

You can use the alphanumeric keyboard to assign names to cues, submasters, groups, and shows. Names can consist of letters, numbers or the symbols **#, %, &, \*, (, ), +, ', -, [, ], /** as well as the comma and period.

Follow these steps to name a cue, submaster or group:

1. Press [Stage], [Blind] or [Fader] to select a display mode.
2. Press [Cue], [Submaster] or [Group], then use the console's number keys to select the desired cue, submaster or group.
3. Press [Label] on the console or [F5] on the keyboard, and type the desired name on the alphanumeric keyboard. Names can have up to 16 characters.

You may enter the name using overwrite or insert mode. In overwrite, you type over any previously entered characters; in insert mode, each new character pushes the previously entered characters one space to the right. Press [Insert] on the keyboard to toggle between insert and overwrite mode.

4. Press [Enter] on the alphanumeric keyboard to record the name, or press [Esc] to quit and return to the original Insight 2 display screen.

*Note: Press [F8] on the alphanumeric keyboard to advance to the next cue, submaster or group. Press [F7] to go to the previous cue, submaster or group. Press [F6] to clear the name from the cursor to the end of the line.*

### ***Naming shows***

To name a show, press [Setup] [S1], **Show Name**, then use the alphanumeric keyboard to enter the show's name.

# chapter 19

## sensor dimming

Insight 2 lighting control systems may be connected to ETC Sensor dimming systems via the ETCLink communication network. In this configuration, the Insight 2 can provide you with a wide range of system status information, including overall system status and specific information about individual dimmer modules and dimmer racks.

You may access ETCLink through the ETCLink Functions menu. Most of the dimmer, rack and system information accessible through Insight 2 displays is also available from your Sensor dimming system through the Control Electronics Module (CEM).

To reach the ETCLink Functions menu, press [Setup] [9] [Enter]. The following display appears:

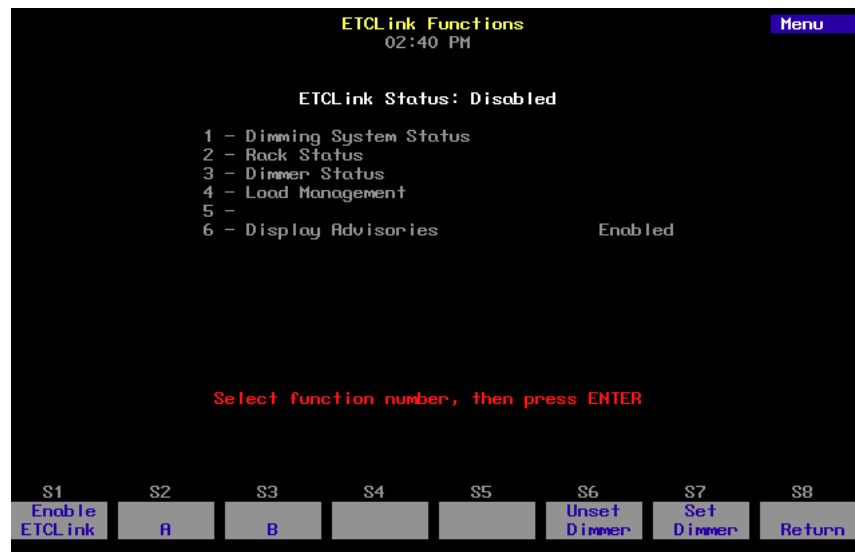

# Enabling ETCLink

Before using ETCLink functions, you must connect the system to the ETCLink network. Follow these steps to activate your ETCLink connection, allowing you to monitor the dimming system:

| <b>Keystrokes:</b>   | <b>Action:</b>   |
|--|--|
| 1. Press [Setup].  | Selects Setup menu.  |
| 2. Select 6, <b>Options Settings</b> , and press [Enter].                                  | Selects Options Settings menu  |
| 3. Press [8], <b>ETCLink</b> , [Enter].  | Prompt reads:<br><b>Enable/disable ETCLink (1 = Enable, 0 = Disable)</b> |
| 4. Press [1] [Enter].  | Dimmer Monitoring is enabled   |
| 5. If you wish to change the ETCLink address, press [9], <b>ETCLink Address</b> , [Enter]. | Prompt reads:<br><b>Select ETCLink address</b>                           |
| 6. Press [1] [Enter]. (ETCLink address may be <b>1</b> or <b>2</b> .)                      | ETCLink address is changed   |

*Note: If you change the ETCLink address, you must cycle power to the console before the new address will take effect.*

## Enabling ETCLink messages

If you wish ETCLink advisory messages to be displayed while you are operating the console, you must enable them from the ETCLink Functions menu.

To enable advisories, follow these steps:

| <b>Keystrokes:</b>  | <b>Action:</b>   |
|---|--|
| 1. Press [Setup].   | Selects Setup display  |
| 2. Select [9], <b>ETCLink Functions</b> , and press [Enter].  | Selects ETCLink Functions menu   |
| 3. Select [6], <b>Display Advisories</b> , and press [Enter]. | Prompt reads:<br><b>Enable/disable display of ETCLink advisories (1 = Enable all, 2 = Enable fatal error advisories only, 0 = Disable)</b> |
| 4. Press [1] [Enter].   | All ETCLink advisories are enabled   |

*Note: To disable some or all advisories, follow the same steps, but select **0** or **2** in step 4*

## Monitoring dimmers

When used in conjunction with Sensor dimming equipment, the Insight 2 allows you to monitor individual dimmer loads in your system. This can greatly simplify troubleshooting by identifying such things as burned out lamps, and incorrectly lamped or unplugged fixtures.

When dimmer monitoring is in use, Sensor electronics constantly monitor dimmer loads. If there is an unexpected fluctuation of more than 20 percent in the load on any dimmer, a message identifying the dimmer and describing the problem is displayed in a window on one of the console's display screens. (Note: Error messages are also displayed on the system's Sensor CEMs.)

In order to monitor normal dimmer loads, the system must first *learn* what constitutes a normal load. Record Loads is the operation that allows you to *teach* the system what the range of normal loads is. You may Record Loads either from the Insight 2, or from a Sensor AF CEM.

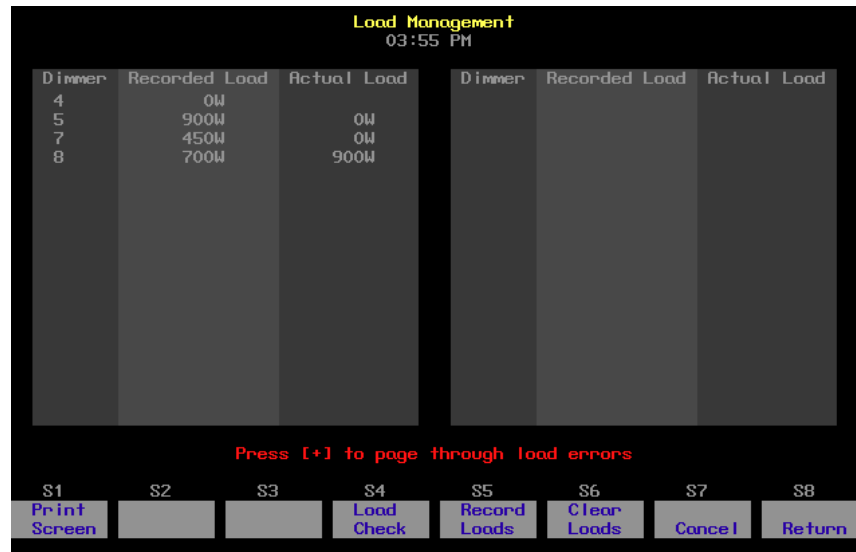

The screenshot shows a 'Load Management' window with a timestamp of 03:55 PM. It contains two tables side-by-side. The left table shows recorded and actual loads for dimmers 4, 5, 7, and 8. The right table is empty. Below the tables is a red instruction: 'Press [+] to page through load errors'. At the bottom is a control panel with buttons labeled S1 through S8.

| Dimmer | Recorded Load | Actual Load | Dimmer | Recorded Load | Actual Load |
|--------|---------------|-------------|--------|---------------|-------------|
| 4      | 0W            |             |        |               |             |
| 5      | 900W          | 0W          |        |               |             |
| 7      | 450W          | 0W          |        |               |             |
| 8      | 700W          | 900W        |        |               |             |

Press [+] to page through load errors

|              |    |    |            |              |             |        |        |
|--------------|----|----|------------|--------------|-------------|--------|--------|
| S1           | S2 | S3 | S4         | S5           | S6          | S7     | S8     |
| Print Screen |    |    | Load Check | Record Loads | Clear Loads | Cancel | Return |

You should run Record Loads any time you relamp your fixtures, change the type of fixtures you are using, change the dimmer numbering scheme, or make any other significant changes to your system. In general, Record Loads should be the last step in setting up your system. Loads are recorded from the Load Management display, shown above.

*Note: Loads may not be recorded on Sensor systems without the AF option. See the Sensor CEM Users Manual for more information on recording loads from your dimming system.*

## Recording dimmer loads

When you Record Loads, the system records load information only for the dimmers set at a level above zero. Choose the dimmers you wish to record, set them to a level, then run Record Loads.

Record Loads records 24 dimmers per rack at a time until all dimmers at levels above zero have been recorded. (If you have multiple racks, 24 dimmers in each rack are recorded simultaneously.)

*Note: On single phase racks, the system records 16 dimmers per rack at a time.*

*Caution: Record Loads changes levels on stage. Dimmer outputs rise and fall for several minutes during the procedure. To cancel a Record Load operation that has already started, press [S7], **Cancel**, [Enter].*

Follow these steps to Record Loads for your system.

### Keystrokes:

### Action:

- |   |                                 |
|---|---------------------------------|
| 1. Set desired dimmers to a level above zero. Only dimmers at levels above zero are recorded. |                                 |
| 2. Press [Setup].   | Selects Setup display           |
| 3. Select [9], <b>ETCLink Functions</b> , and press [Enter].                                  | Selects ETCLink Functions menu  |
| 4. Select [4], <b>Load Management</b> , and press [Enter].                                    | Selects Load Management display |

*Note: If you wish, instead of setting the desired dimmers to a level in step 1, you may enter a list of dimmers to record in step 5.*

- |   |  |
|---|--|
| 5. Press [S5], <b>Record Loads</b> . If you wish, you may enter a specific dimmer or dimmers to record. | Prompt reads:<br><b>To record loads, select dimmer(s) and press ENTER (Enter 0 to record loads for all dimmers)</b>  |
| 6. Press [0] [Enter].   | Advisory reads:<br><b>New loads will be recorded for all dimmers with levels above zero. Levels on stage will change while the Record Load is in progress. The system will automatically vary the dimmer outputs during the Record Load. The process may take several minutes to complete.</b> |
|   | Press [Enter] to proceed, or press [Clear] to cancel   |
| 7. Press [Enter] to proceed with the load record, or press [Clear] to cancel the operation.             | New loads are recorded for all dimmers with levels above zero  |

## Checking dimmer loads

Load Check compares the current load on selected dimmers with their recorded loads. Loads that differ by more than 20 percent are shown in the Load Management display. Use [Page +] and [Page -] to page through the display. The system checks load information only for selected dimmers. To identify the dimmer(s) you wish to check, use either the Insight 2 or the CEM to set the desired dimmers at a level above zero.

The system checks 24 dimmers per rack at a time until all dimmers at levels above zero have been checked. (If you have multiple racks, 24 dimmers in each rack are checked simultaneously.)

*Note: On single phase racks, the system checks 16 dimmers per rack at a time.*

*Caution: Load Check changes levels on stage. Dimmer outputs rise and fall for several minutes during the procedure. To cancel a check load operation in progress, press [S7], **Cancel**, [Enter].*

Follow these steps to check loads for your system.

| <b>Keystrokes:</b>   | <b>Action:</b>                  |
|--|---------------------------------|
| 1. Set dimmers to be checked to a level above zero. Only dimmers above zero are checked. |                                 |
| 2. Press [Setup].  | Selects Setup display           |
| 3. Select [9], <b>ETCLink Functions</b> , and press [Enter].                             | Selects ETCLink Functions menu  |
| 4. Select [4], <b>Load Management</b> , and press [Enter].                               | Selects Load Management display |

*Note: If you wish, instead of setting the desired dimmers to a level in step 1, you may enter a list of dimmers to record in step 5.*

5. Press [S4], **Load Check**.  
(You may enter specific dimmers to check.)

Prompt reads:

**To check loads, select dimmer(s) and press ENTER (Enter 0 to check loads for all dimmers)**

6. Press [0] [Enter].

Advisory reads:

**All dimmers with levels above zero will have their loads checked. Levels on stage will change while the Load Check is in progress. The system will automatically vary the dimmer outputs during the Load Check. The process may take several minutes to complete.**

Press [Enter] to proceed, or press [Clear] to cancel

7. Press [Enter] to proceed with the load check, or press [Clear] to cancel the operation.

Loads are checked for all dimmers with levels above zero

Once complete, advisory reads:

**Record Loads processing has completed  
Press any key to continue**

## Clearing dimmer loads

Clear Loads allows you to clear selected dimmer loads, thus disabling dimmer monitoring for those dimmers. This can be useful if you know that the load on a dimmer or group of dimmers will change over the course of a show and don't want to receive load error messages every time it happens.

To clear loads, follow these steps:

| <b>Keystrokes:</b>   | <b>Action:</b>  |
|--|---|
| 1. Press [Setup].  | Selects Setup display   |
| 2. Select [9], <b>ETCLink Functions</b> , and press [Enter].   | Selects ETCLink Functions menu  |
| 3. Select [4], <b>Load Management</b> , and press [Enter].   | Selects Load Management display   |
| 4. Press [S6], <b>Clear Loads</b> .<br>(If you wish, you may enter a specific dimmer or dimmers to clear.) | Prompt reads:<br><b>To clear loads, select dimmer(s) and press ENTER (Enter 0 to clear loads for all dimmers)</b>   |
| 5. Press [0] [Enter].  | Advisory reads:<br><b>Recorded loads will be erased for all dimmers with levels above zero, disabling load error messages for those dimmers.</b><br><br><b>Press [Enter] to proceed, or press [Clear] to cancel</b> |
| 6. Press [Enter] to proceed with the load clear, or press [Clear] to cancel the operation.                 | Loads are cleared for all dimmers with levels above zero<br><br>Once complete, advisory reads:<br><b>Clear Loads processing has completed</b><br><b>Press any key to continue</b>                                   |

## Load errors

When a dimmer's load isn't within 20 percent of its recorded load, it generates a load error that appears on the Load Management display. The information shown on the Load Management display includes the dimmer number, the recorded load of the dimmer, and the actual load the system has detected for that dimmer.

| Load Management |               |             |        |               |             |
|-----------------|---------------|-------------|--------|---------------|-------------|
| 03:55 PM        |               |             |        |               |             |
| Dimmer          | Recorded Load | Actual Load | Dimmer | Recorded Load | Actual Load |
| 4               | 0W            |             |        |               |             |
| 5               | 900W          | 0W          |        |               |             |
| 7               | 450W          | 0W          |        |               |             |
| 8               | 700W          | 900W        |        |               |             |

Press [+] to page through load errors

|              |    |    |            |              |             |        |        |
|--------------|----|----|------------|--------------|-------------|--------|--------|
| S1           | S2 | S3 | S4         | S5           | S6          | S7     | S8     |
| Print Screen |    |    | Load Check | Record Loads | Clear Loads | Cancel | Return |

Follow these steps to list all dimmers that have load errors:

### Keystrokes:

1. Press [Setup].
2. Select [9], **ETCLink Functions**, and press [Enter].
3. Select [4], **Load Management**, and press [Enter].

### Action:

1. Selects Setup display
2. Selects ETCLink Functions menu
3. Selects Load Management display

*Note: If you have a printer attached to your console, you may print the Load Errors screen. To print a list of dimmer load errors from this screen, press [S1], **Print Screen**. The console sends the Load Error list to the printer.*

# Sensor dimming system status

The System Status display provides information about your Sensor dimming system. Press [Setup] [9] [Enter] [1] [Enter] to access the System Status display.

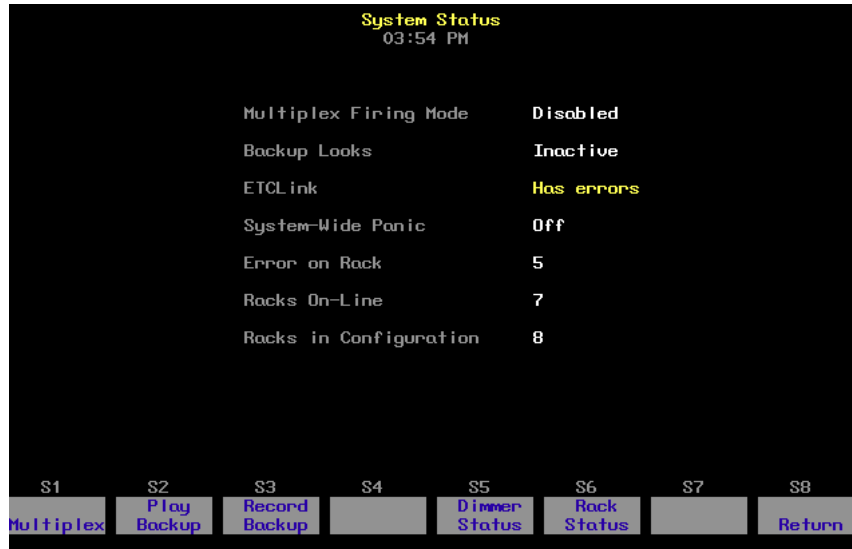

- **Multiplex firing mode** shows whether Multiplex mode is enabled or disabled for your system. If Multiplex mode is disabled, dimmers in multiplex mode function as normal dimmers.
- **Backup looks** indicates whether a backup look is active, and, if so, which one.
- **ETCLink** displays any ETCLink errors.
- **System-wide panic** displays status of system-wide panic.
- **Error on rack** displays the number of the rack with an ETCLink error. If errors exist on multiple racks, the first rack with an error is displayed.
- **Racks on-line** displays the number of racks presently on-line throughout the ETCLink network.
- **Racks in configuration** displays the total number of racks in the system.



## Dimmer status

The Dimmer Status display provides information about dimmers, including size and type, recorded load, firing mode, output curve, rack, slot, panic mode, and boost. Press [Setup] [9] [Enter] [3] [Enter] to access the Dimmer Status display.

| Dimmer Status |              |               |             |        |      |      |            |        |
|---------------|--------------|---------------|-------------|--------|------|------|------------|--------|
| 03:55 PM      |              |               |             |        |      |      |            |        |
| Dimmer        | Type         | Recorded Load | Firing Mode | Curve  | Rack | Slot | Panic Mode | Boost: |
| 1             | 20A Feedback | 1200W         | --          | Square | 1    | 1    | --         | --     |
| 2             | 20A Feedback | 650W          | --          | Square | 1    | 1    | --         | 102%   |
| 3             | 20A Feedback | 1200W         | --          | Square | 1    | 2    | --         | 116%   |
| 4             | 20A Feedback | 900W          | --          | Square | 1    | 2    | --         | --     |
| 5             | 20A Feedback | 900W          | --          | Square | 1    | 3    | --         | --     |
| 6             | 20A Feedback | 900W          | --          | Square | 1    | 3    | --         | --     |
| 7             | 20A Feedback | 450W          | --          | Square | 1    | 4    | --         | 104%   |
| 8             | 20A Feedback | 700W          | --          | Square | 1    | 4    | --         | --     |
| 9             | 20A Feedback | 0W            | --          | Square | 1    | 5    | --         | --     |
| 10            | 20A Feedback | 0W            | --          | Square | 1    | 5    | --         | --     |
| 11            | 20A Feedback | 0W            | --          | Square | 1    | 6    | --         | --     |
| 12            | 20A Feedback | 0W            | --          | Square | 1    | 6    | --         | --     |
| 13            | 20A Feedback | 0W            | --          | Square | 1    | 7    | --         | --     |
| 14            | 20A Feedback | 0W            | --          | Square | 1    | 7    | --         | --     |
| 15            | 20A Feedback | 0W            | --          | Square | 1    | 8    | --         | --     |
| 16            | 20A Feedback | 0W            | --          | Square | 1    | 8    | --         | --     |

Press [+] or [-] to page through dimmers

|    |    |    |               |               |             |    |        |
|----|----|----|---------------|---------------|-------------|----|--------|
| S1 | S2 | S3 | S4            | S5            | S6          | S7 | S8     |
|    |    |    | System Status | Select Dimmer | Rack Status |    | Return |

- **Type** shows the dimmer's amperage, and whether the dimmer is high-rise or standard. (**Feedback** indicates that the dimmers are Advanced Features modules.)
- **Recorded load** displays the load at which the selected dimmer was recorded.
- **Firing mode** indicates whether the dimmer is normal, multiplexed, or switched. "--" indicates a normal firing mode.
- **Curve** indicates the output curve assigned to the dimmer. "--" equals 00.
- **Rack** indicates the number of the rack where the dimmer is located.
- **Slot** indicates the number of the slot in the rack where the dimmer is located.
- **Panic mode** indicates whether the dimmer is assigned to a panic circuit. "--" indicates an unassigned dimmer.
- **Boost** indicates the dimmer's Boost level. "--" indicates a Boost level of 100 percent.

Up to 16 dimmers are shown on the display at once, along with error messages associated with each dimmer. Press [S5], **Select Dimmer**, [#] [Enter] to select a specific dimmer or use [+] and [-] to move through the list of dimmers a page at a time.

## Setting and unsetting dimmers

If your console is connected to an ETC Sensor dimming system by an ETCLink network, you may use your console to set and unset dimmers at the dimmer rack.

*Note: For more information on setting dimmers, see the Sensor CEM User Manual.*

### Setting a dimmer

To set a dimmer or group of dimmers to a level at the dimmer rack, ignoring any DMX512 outputs, follow these steps:

| Keystrokes:  | Action:   |
|--|---|
| 1. Press [Setup].  | Selects Setup display   |
| 2. Select [9], <b>ETCLink Functions</b> , and press [Enter].   | Selects ETCLink Functions menu  |
| 3. Press [S7], <b>Set Dimmer</b> .   | Prompt reads:<br><b>Select dimmer number(s) to set, then press ENTER</b><br><b>(To cancel, press CLEAR)</b> |
| 4. Enter the dimmers you wish to set and press [Enter].  | Prompt reads:<br><b>Select dimmer level</b><br><b>(Press FULL button for 100%)</b>                          |
| 5. Enter the level at which to set the dimmers. Enter in two-digit form (e.g., one percent = <b>01</b> ) | Advisory reads:<br><b>To confirm, press ENTER</b><br><b>To cancel, press CLEAR</b>                          |
| 6. Press [Enter].  | Dimmers are set to desired level  |

### Unsetting a dimmer

To unset a dimmer or group of dimmers and return them to normal operation, follow these steps:

| Keystrokes:   | Action:   |
|---|---|
| 1. Press [Setup].   | Selects Setup display   |
| 2. Select [9], <b>ETCLink Functions</b> , and press [Enter].  | Selects ETCLink Functions menu  |
| 3. Press [S6], <b>Unset Dimmer</b> .  | Prompt reads:<br><b>Select dimmer number(s) to unset, then press ENTER</b><br><b>(Enter 0 to unset all dimmers)</b> |
| 4. Enter the dimmers you wish to unset and press [Enter]. Press [0] [Enter] to unset all set dimmers. | Prompt reads:<br><b>To confirm, press ENTER</b><br><b>To cancel, press CLEAR</b>                                    |
| 5. Press [Enter].   | Dimmers are unset   |

## Working with Sensor backup looks

A backup look is a recording of a selected look on stage stored in the Sensor CEM. The Sensor system allows you to use either your Insight 2 console or any CEM to bring that look up on stage. You may save and use up to 32 backup looks.

### Recording a backup look

To record a backup look, follow these steps:

| Keystrokes:  | Action:  |
|--|--|
| 1. Use your console to create the desired look on stage.     | Creates look on stage  |
| 2. Press [Setup].  | Selects Setup display  |
| 3. Select [9], <b>ETCLink Functions</b> , and press [Enter]. | Selects ETCLink Functions menu   |
| 4. Press [1], <b>Dimming System Status</b> , [Enter].        | Selects System Status display  |
| 5. Press [S3], <b>Record Backup</b> .                        | Prompt reads:<br><b>Select backup look to record, then press ENTER</b>                       |
| 6. Enter the backup look number (1-32) and press [Enter].    | Advisory reads:<br><b>Record Backup processing has completed. Press any key to continue.</b> |

## ***Playing a backup look***

Playing a backup look brings up the recorded look on stage. You may play back a backup look from the console or from a CEM.

Only one backup look may be on stage at a time. If there is a backup look on stage when you bring up a new one, the second look replaces the first.

Up and down fade times for backup looks are five seconds. They cannot be modified.

To use the Insight 2 to play a recorded backup look, follow these steps:

| <b>Keystrokes:</b>   | <b>Action:</b>   |
|--|--|
| 1. Press [Setup].  | Selects Setup display  |
| 2. Select [9], <b>ETCLink Functions</b> , and press [Enter]. | Selects ETCLink Functions menu   |
| 3. Press [1], <b>Dimming System Status</b> , [Enter].        | Selects Dimming System Status display  |
| 4. Press [S2], <b>Play Backup</b> .                          | Prompt reads:<br><b>Select backup look to play, then press ENTER (Enter 0 to return to normal operation)</b> |
| 5. Enter the backup look number (1-32) and press [Enter].    | Advisory reads:<br><b>Play Backup processing has completed. Press any key to continue.</b>                   |

*Note: To clear a playing backup look follow the procedure listed above, but enter [0] in step 5 as the backup look number. The currently playing backup look will be cleared from the stage.*

# Error messages

ETCLink provides advisory messages for a wide variety of conditions, including information regarding your dimmers, racks, system, data, ports, and loads. These messages fall into two categories, fatal messages and secondary messages.

Fatal messages deal with anything that could potentially terminate or drastically change the look of your show. You may set fatal messages to be displayed even when secondary messages have been disabled.

Secondary messages deal with individual dimmer problems and warnings of potential rack temperature problems. These messages are generally less critical than the fatal messages. If you wish, secondary messages may be disabled without disabling fatal messages. See *Disabling secondary messages* on page 228 for more information.

Insight 2 displays error messages in advisory windows that appear regardless of which display mode you have chosen. They may also appear in abbreviated forms on the Status and About screens. Advisories are cleared as soon as you enter any keystroke.

For example, suppose the dimming system detects a problem with dimmer 1. As shown on the screen below, an advisory message appears, informing you of the problem.



See *ETCLink errors* on page 307 for a list of possible error messages.

## ***Disabling secondary messages***

You may prevent secondary ETCLink advisory messages from being displayed while you are operating the console. This is done from the ETCLink Functions menu.

For example, if you are rehung a show, a large number of load errors will be generated despite the fact that nothing is actually wrong. Under these circumstances, you might want to turn off the secondary messages until the show is completely rehung and the new loads have been recorded. This would allow the board operator to use the console uninterrupted.

*Note: See page 308 for a list of secondary messages.*

To disable advisories, follow these steps:

| <b>Keystrokes:</b>  | <b>Action:</b>   |
|---|--|
| 1. Press [Setup].   | Selects Setup display  |
| 2. Select [9], <b>ETCLink Functions</b> , and press [Enter].  | Selects ETCLink Functions menu   |
| 3. Select [6], <b>Display Advisories</b> , and press [Enter]. | Prompt reads:<br><b>Enable/disable display of ETCLink advisories</b><br><b>(1 = Enable all, 2 = Enable fatal error advisories only, 0 = Disable)</b> |
| 4. Press [0] [Enter].   | All ETCLink advisories are disabled; to enable advisories, follow the same steps, but select <b>1</b> or <b>2</b> in step 4                          |

# *chapter 20*

## *control interfaces*

Express allows you to control your console and/or remote devices using a variety of external and timed interfaces. This chapter describes the following choices:

- MIDI
- Real Time Clock
- DMX512 Input
- SMPTE
- Remote Macros

## **MIDI**

MIDI (Musical Instrument Digital Interface) is a digital communication protocol that allows you to interconnect musical instruments and digital electronic equipment, such as lighting control consoles. If you are not familiar with MIDI and would like more information on how it works, *Control Systems for Live Entertainment*, by John Huntington, includes several sections that deal with the subject.

Insight 2 supports two versions of MIDI. In addition to ETC MIDI, a proprietary MIDI implementation developed by ETC, you may also use the entertainment lighting industry standard, MIDI Show Control 1.0 (MSC).

### **ETC MIDI**

The console both transmits and receives MIDI messages with any MIDI instrument. The MIDI protocol can operate cues, macros and submaster bump switches.

ETC assumes that MIDI users have a working knowledge of MIDI. This section provides ETC MIDI interface information, message formats and message definitions. See *Installing MIDI* on page 289 for installation information. If you need more technical information about MIDI, contact ETC.

*Note: Macros cannot execute MIDI commands.*

## Configuring ETC MIDI

The console must be configured to operate in MIDI mode. If you have any questions about this, please contact your dealer or ETC.

Once the console is on, the MIDI Channel must be set. Select 1, **ETC MIDI Channel** in the Options Settings menu.

The console operates at all times in MIDI Mode 3 or Omni = off/Poly. This means it only receives or transmits MIDI commands on the user-selected channel. The **Select MIDI Channel** function allows the user to specify the desired channel. Insight 2 ignores all MIDI commands on channels other than the specified one, so be sure your MIDI gear is set to the same channel. The console remembers the selected MIDI channel the next time it is turned on.

Follow these steps to configure Insight 2 for MIDI use:

1. Turn console on.
2. Press [Setup] to display Setup menu. Then select 6, **Options Settings**, and press [Enter] to display the Options Settings menu. The following display appears:



3. Select 1, **ETC MIDI channel**, and press [Enter].
4. Enter the MIDI channel you will use (1-16), and press [Enter]. Verify that your MIDI equipment is also set to the same channel. Insight 2 will ignore MIDI commands on other channels. Press [S1], **Disable MIDI**, to disable ETC MIDI mode.

## ***ETC MIDI message formats***

The following table lists MIDI message formats used to control Insight 2. All numbers are in Hex format.

### ***Note off message format***

<8n><kk><vv>  
8 Note off status  
n MIDI channel number (0-F)  
kk Key number (0-7F)  
vv Note off velocity (0-7F)

### ***Note on message format***

<9n><kk><vv>  
9 Note on status  
n MIDI channel number (0-F)  
kk Key number (0-7F)  
vv Note on velocity (0-7F)  
[00=Note off]

### ***Control change message format***

<Bn><kk><vv>  
B Control change status  
n MIDI channel number (0-F)  
kk Control number (70-92)  
vv Control value (0-7F)

### ***Program change message format***

<Cn><kk>  
C Program (patch) change status  
n MIDI channel number (0-F)  
kk Program number (0-7F)

## **MIDI Message definitions**

### **Submaster bump switch execution**

|                    |          |            |
|--------------------|----------|------------|
| Submasters 1 - 36  | C#0 - C3 | #1 - #36   |
| Submasters 37 - 72 | C#3 - C6 | #37 - #72  |
| Submasters 73-108  | C#6 - C9 | #73 - #108 |

*Note: C5 = MIDI note #60 or middle C.*

### **Cue execution in AB fader pair**

|                |  |
|----------------|--|
| Next cue       | Program change 0                         |
| Cues 1 - 127   | Program change 1 - 127                   |
| Cues 128 - 255 | Controller change 70, parameters 0 - 127 |
| Cues 256 - 383 | Controller change 71, parameters 0 - 127 |
| Cues 384 - 511 | Controller change 72, parameters 0 - 127 |
| Cues 512 - 639 | Controller change 73, parameters 0 - 127 |
| Cues 640 - 767 | Controller change 74, parameters 0 - 127 |
| Cues 768 - 895 | Controller change 75, parameters 0 - 127 |
| Cues 896 - 999 | Controller change 76, parameters 0 - 103 |

### **Cue execution in CD fader pair**

|                |  |
|----------------|--|
| Next cue       | Controller change 77, parameter 0        |
| Cues 1 - 127   | Controller change 77, parameters 1- 127  |
| Cues 128 - 255 | Controller change 78, parameters 0 - 127 |
| Cues 256 - 383 | Controller change 79, parameters 0 - 127 |
| Cues 384 - 511 | Controller change 80, parameters 0 - 127 |
| Cues 512 - 639 | Controller change 81, parameters 0 - 127 |
| Cues 640 - 767 | Controller change 82, parameters 0 - 127 |
| Cues 768 - 895 | Controller change 83, parameters 0 - 127 |
| Cues 896 - 999 | Controller change 84, parameters 0 - 103 |

### **Macro execution**

|                  |  |
|------------------|--|
| Macros 1 - 127   | Controller change 85, parameters 1 - 127 |
| Macros 128 - 255 | Controller change 86, parameters 0 - 127 |
| Macros 256 - 383 | Controller change 87, parameters 0 - 127 |
| Macros 384 - 511 | Controller change 88, parameters 0 - 127 |
| Macros 512 - 639 | Controller change 89, parameters 0 - 127 |
| Macros 640 - 767 | Controller change 90, parameters 0 - 127 |
| Macros 768 - 895 | Controller change 91, parameters 0 - 127 |
| Macros 896 - 999 | Controller change 92, parameters 0 - 103 |

## ***MIDI Show Control (MSC)***

The consoles recognize the following MSC commands:

- Go
- Stop
- Resume
- Fire

The consoles ignore all other commands.

The commands can be received and/or transmitted.

## Configuring MIDI Show Control

Each device receiving MIDI Show Control information must be assigned a device ID. Insight 2 can receive MSC information, transmit MSC information, or both.

To enable input and/or output of MSC and to assign MSC device IDs for incoming and outgoing data, do the following:

1. Press [Setup] to go to the Setup menu.
2. Press [6] [Enter] to select the Options Settings menu. The following display appears:



3. Press [2] [Enter]. The message **Select MIDI receiver device (#0 - 126), or press DISABLE MIDI to disable MIDI Show Control** appears.
4. Enter the receiver device ID (the ID of the device generating the MSC signal to which the console is listening). The ID must be between zero and 126.
5. Press [Enter]. The message **Select MIDI transmitter device (#0 - 126), or press DISABLE MIDI to disable MIDI Show Control** appears.
6. Enter the transmitter device ID (the ID of the device to which the console is transmitting MIDI signal). The ID must be between zero and 126. Press [Enter].

### Disable MIDI Show Control

To disable MIDI Show Control from the Options Settings menu, press [2] [Enter] [S1], **Disable MIDI**.

## MSC commands received by Insight 2

Insight 2 consoles enabled for MSC accept the following MSC commands. When the console receives one of these commands, it executes the command immediately. In order to accept MSC commands, the console's receiver **Device ID** must match the target device ID for the MIDI device sending the signals.

|               |   |
|---------------|---|
| <b>Go</b>     | <p>If no cue number is sent, <b>Go</b> presses [A/B Go] on Insight 2. The next cue on the cue list runs in the A/B fader.</p> <p>If a cue number is sent, the specified cue runs on the A/B fader.</p> <p>If a cue number is sent, and <b>2</b> is sent as the list entry, that cue runs on the C/D fader.</p> <p>If cue <b>0</b> is sent, and <b>2</b> is sent as the list entry, the command presses [C/D Go]. The pending cue runs in the C/D fader. You may also press [A/B Go] by sending <b>Go-Cue 0-1</b>.</p> |
| <b>Stop</b>   | <p>The <b>Stop</b> command by itself holds all fades in both fader pairs.</p> <p>If Stop is sent with a cue number and a list entry of 1, only the cue running in the A/B fader holds.</p> <p>If Stop is sent with a cue number and a list entry of 2, only the cue running in the C/D fader holds.</p> <p>The cue number field is ignored, but must be included if a list entry is sent.</p>   |
| <b>Resume</b> | <p>The <b>Resume</b> command by itself resumes all holding fades in both fader pairs.</p> <p>If Resume is sent with a cue number and a list entry of 1, only a cue holding in the A/B fader resumes.</p> <p>If Resume is sent with a cue number and a list entry of 2, only the cue holding in the C/D fader resumes.</p> <p>The cue number field is ignored, but must be included if a list entry is sent.</p>   |
| <b>Fire</b>   | <p>The <b>Fire</b> command executes a specified macro. Macro number must be in the range 1-127. If no macro is specified, or if the macro number is out of range, the command is ignored.</p>   |

## ***MSC commands transmitted by Insight 2***

MIDI Show Control (MSC) allows the console to send the following commands to MIDI devices. If MSC output is enabled on the console, the console automatically sends the MSC commands. The console's transmitter **Device ID** must match the device ID for the MIDI device receiving the signals.

|                   |  |
|-------------------|--|
| <b>[A/B Go]</b>   | If a cue is pending, the console transmits [A/B Go] with cue number and a list entry of 1.<br><br>If a cue is holding, the console transmits [A/B Resume] with cue number and a list entry of 1. |
| <b>[C/D Go]</b>   | If a cue is pending, the console transmits [C/D Go] with cue number and a list entry of 2.<br><br>If a cue is holding, the console transmits [C/D Resume] with cue number and a list entry of 2. |
| <b>[A/B Hold]</b> | If a cue is running, the console transmits [A/B Stop] with cue number and a list entry of 1.   |
| <b>[C/D Hold]</b> | If a cue is running, the console transmits [C/D Stop] with cue number and a list entry of 2.   |
| <b>Macros</b>     | For macros 1-127, the console transmits <b>Fire</b> with the macro number.   |

## ***Real time clock***

The Real Time Clock allows you to program macros to run in real time, that is to run automatically at any time of day, on any day of the week. For example, you might program the work lights to come on for a choir rehearsal between 7 PM and 9 PM on Monday and Wednesday. Or, you might want to warm the filaments of your studio instruments 15 minutes prior to your news program.

You can record up to 500 real time programs. This section includes instructions for creating and editing real time programs. See *System Settings* for instructions on setting the real time clock.

## ***Real time programs***

The system will run recorded macros at specific times on specified days. Real time programs must be enabled before they will function.

### ***Enabling real time programs:***

To enable or disable real time programs, follow these steps. Default is enabled.

| <b>Keystrokes:</b>       | <b>Action:</b>  |
|--------------------------|---|
| 1. Press [Setup].        | Selects Setup display mode  |
| 2. Press [6] [Enter].    | Selects Options Settings menu   |
| 3. Press [1][1] [Enter]. | Selects Real Time Programs<br>Prompt reads:<br><b>Enable/Disable real time programs<br/>(1 = enable, 0 = disable)</b> |
| 4. Press [1] [Enter].    | Enables Real Time Programs.   |

*Note: To disable Real Time programs, repeat procedure and enter zero in step 4.*

## ***Creating real time programs***

Follow these steps to create a real time program.

| <b>Keystrokes:</b>                                  | <b>Action:</b>   |
|---|--|
| 1. Press [Setup].                                   | Selects Setup display mode   |
| 2. Press [1][2] [Enter].                            | Selects Real Time Programs display   |
| 3. Press [S1], <b>Select Program</b> , [1] [Enter]. | Prompt reads:<br><b>Enter time (12 hour clock)</b><br><b>Press [+] to enter AM or PM</b>                                 |
| 4. Press [8][0][0] [Enter].                         | Enters time to run macro<br>Prompt reads:<br><b>Enter days of week (1=Mon, 2=Tue, 3=Wed, 4=Thu, 5=Fri, 6=Sat, 7=Sun)</b> |
| 5. Press [1] [And] [3] [Thru] [5] [Enter].          | Enters days to run macro<br>Prompt reads:<br><b>Enter macro number</b>   |
| 6. Press [5] [Enter].                               | Creates real time program 1. Macro 5 will run at 8 AM every Monday, Wednesday, Thursday and Friday.                      |

## Editing real time programs

Once you have created a real time program, you can easily make changes in the Real Time Programs display. Press [←], [→], [↑] or [↓] to move the highlight. When you reach the right end of a line, press [→] to move to the next line. When you reach the last line, press [↓] and enter a time to add a new program.

## Deleting real time programs

To delete real time programs, follow these steps.

*Note: The Clear Real Time Programs menu option on the Clear menu allows you to delete all recorded programs.*

| Keystrokes:                           | Action:  |
|---------------------------------------|--|
| 1. Press [Setup].                     | Selects Setup display mode   |
| 2. Press [1][2] [Enter].              | Selects Real Time Programs display   |
| 3. Press [S6], <b>Delete Program.</b> | Prompt reads:<br><b>Select program number(s) to delete, then press ENTER</b><br><b>To cancel, press CLEAR</b>          |
| 4. Press [5] [And] [6] [Enter].       | Selects programs 5 and 6 to delete<br>Prompt reads:<br><b>To confirm, press ENTER</b><br><b>To cancel, press CLEAR</b> |
| 5. Press [Enter].                     | Deletes programs 5 and 6   |

## Inserting real time programs

| Keystrokes:  | Action:  |
|--|--|
| 1. Press [Setup].  | Selects Setup display mode   |
| 2. Press [1][2] [Enter].                                   | Selects Real Time Programs display   |
| 3. Press [S7], <b>More Softkeys, [S1], Insert Program.</b> | Prompt reads:<br><b>Select program number to insert, then press ENTER</b><br><b>To cancel, press CLEAR</b>   |
| 4. Press [4] [Enter].                                      | Selects program 4 to insert before<br>Prompt reads:<br><b>Select number of programs to insert, then press ENTER</b><br><b>To cancel, press CLEAR</b> |
| 5. Press [2] [Enter].                                      | Inserts two new programs before program 4. All following programs are renumbered   |

## ***Copying real time programs***

| <b>Keystrokes:</b>  | <b>Action:</b>  |
|---|---|
| 1. Press [Setup].   | Selects Setup display mode  |
| 2. Press [1][2] [Enter].  | Selects Real Time Programs display  |
| 3. Press [S7], <b>More Softkeys</b> , [S2], <b>Copy Program</b> . | Prompt reads:<br><b>Select program number(s) to copy, then press ENTER</b><br><b>To cancel, press CLEAR</b>   |
| 4. Press [1] [Thru] [5] [Enter].                                  | Selects programs 1 through 5 to copy<br>Prompt reads:<br><b>To copy selected programs(s), select time and press ENTER</b><br><b>Press [+] to enter AM or PM</b> |
| 5. Press [7][0][0] [+] [Enter].                                   | Copies program 1 to a new program starting at 7:00 AM; the rest of the programs maintain their original relationship in time                                    |

## ***Moving real time programs***

You may move one or more real time programs from one time slot to another. (To move a single program, you may also use the arrow keys to highlight the time for the program you want to move, use the keypad to enter the new time, then press [Enter].)

| <b>Keystrokes:</b>  | <b>Action:</b>  |
|---|---|
| 1. Press [Setup].   | Selects Setup display mode  |
| 2. Press [1][2] [Enter].  | Selects Real Time Programs display  |
| 3. Press [S7], <b>More Softkeys</b> , [S3], <b>Move Program</b> . | Prompt reads:<br><b>Select program number(s) to move, then press ENTER</b><br><b>To cancel, press CLEAR</b>   |
| 4. Press [1] [Thru] [5] [Enter].                                  | Selects programs 1 through 5 to move<br>Prompt reads:<br><b>To move selected programs(s), select time and press ENTER</b><br><b>Press [+] to enter AM or PM</b> |
| 5. Press [5][0][0] [Enter].                                       | Copies program 1 to a new program starting at 5:00 PM; the rest of the programs maintain their original relationship in time.                                   |

## DMX512 input

The DMX In feature allows you to combine console output with output from a second source of DMX512 (for example, a moving lights console). DMX512 input from the secondary source is routed through the main console and combined with the main DMX512 output signal.

In this scenario, the secondary DMX512 source maintains nominal control of its own levels, but a predetermined submaster on the main console has proportional control. On Insight 2, this proportional control is assigned to submaster 108. The submaster does not control independent channels.

*Note: While DMX In is enabled, submaster 108's normal recorded function is disabled. When DMX In is disabled, the submaster's normal function is restored.*

### DMX In Fader display

The Fader display's DMX In display option allows you to view the DMX In levels that are currently live on Stage. Press [Fader] [4] to select the DMX In Fader display.

### DMX In softkey

The DMX In softkey appears on the Stage and Fader displays. Use the softkey to record only the DMX512 input levels into a cue, group or sub.

For example, to record current DMX512 input into a cue, follow these steps:

| Keystrokes:                           | Action:   |
|---------------------------------------|---|
| 1. Press [Stage].                     | Selects Stage display   |
| 2. Press [S7], <b>More Softkeys</b> . | Reveals second set of Stage softkeys  |
| 3. Press [Record] [Cue] [8].          | Selects cue 8 to record<br>Prompt reads: <b>To record cue, select number and press ENTER</b><br><b>To cancel, press CLEAR</b> |
| 4. Press [S8], <b>DMX In</b> .        |   |
| 5. Press [Enter].                     | Records only current DMX In levels into cue 8   |

### DMX In starting channel

In order to enable DMX In, you must set the DMX In starting channel. The starting channel is the channel to which the first DMX In channel level will be assigned.

DMX512 levels from another source pile onto the levels set by your console. In other words, a channel set to two different levels goes to the higher of the levels. For this reason, it usually makes sense to assign the incoming levels to a range of channels that are not being actively used by your console.

For example, say you are using channels 1 through 200 in your show. You then use DMX In to bring in ten DMX512 levels from another console. If you set your DMX In starting channel as channel 201, the DMX In levels control channels 201 through 210.

## Enabling DMX In

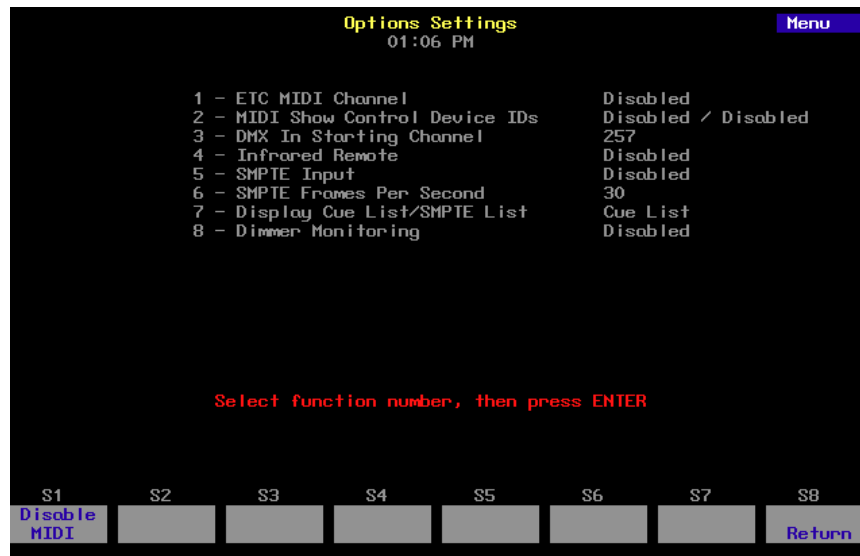

To enable the console to accept DMX512 input, follow these steps:

### Keystrokes:

1. Press [Setup].
2. Press [6] [Enter].
3. Press [3] [Enter].
4. Enter the first channel to be controlled by DMX In and press [Enter]. See *DMX In starting channel* on page 242 for more information.
5. If submaster 108's red LED is flashing, move its slider to 10, then to zero. If its green LED is flashing, move its slider to zero.

### Action:

- Selects Setup menu
- Selects Options Settings menu
- Prompt reads:  
**Select DMX512 In starting channel  
(Enter 0 to disable)**
- Enables DMX In and selects desired starting channel
- The DMX In slider is set to control DMX In; red and green LEDs both light

*Note: On Insight 2 consoles the submaster sliders must be in Submaster Mode to enable DMX In. Use the [Sub Mode] key to set the sliders to Submaster Mode.*

# SMPTE

Your console allows you to create and run shows controlled automatically by SMPTE time code. Shows consist of a series of lighting cues, submasters and macros programmed to play back at specified times. SMPTE times are provided by an internal SMPTE time clock. If you wish to run shows using SMPTE time code from an external source, you must purchase the optional SMPTE upgrade.

A SMPTE program consists of up to 3,000 individual SMPTE events and a Reset Loop time of up to 24 hours. A SMPTE event consists of any combination of two cues loaded in faders (one cue per fader), a submaster bump button, and a macro. The event is programmed to play back at a specified SMPTE time. SMPTE times are expressed in hours, minutes, seconds, and frames. Thirty frames equal one second. For example, 00:25:30:17 is twenty-five minutes, thirty seconds and seventeen frames. Up to 32 events may be assigned to the same SMPTE time.

*Note: You may change the number of frames per second to 24 or 25 in the Options Settings menu.*

The Reset Loop time allows you to set when the SMPTE program loop repeats. The Reset Loop time can be changed at any time, but you will most often set it when you are creating or editing your SMPTE program.

If you purchase the external SMPTE option, the system will run recorded SMPTE events in response to SMPTE time code it receives from an external source. If the flow of SMPTE data to the system is interrupted, the internal clock takes over and begins to generate its own time code. This allows the SMPTE program to continue to run even if the flow of external SMPTE data is stopped. Contact ETC for more information about this option.

*Note: SMPTE must be enabled on your console before you can create or run SMPTE programs. This requires setting DIP switch 4 to **On**. See page 291 for more details.*

## Enabling SMPTE input

Before you can run SMPTE programs driven by an external SMPTE time source, you must enable the SMPTE port. To enable the SMPTE port, follow these steps.

| Keystrokes:  | Actions:  |
|--|---|
| 1. Press [Setup].  | Selects Setup display   |
| 2. Press [6], <b>Options Settings</b> , and press [Enter]. | Selects Options Settings menu   |
| 3. Press [5], <b>SMPTE Input</b> , [Enter].                | Prompt reads:<br><b>Enable/disable external SMPTE input (1 = Enable, 0 = Disable)</b> |
| 4. Press [1] [Enter].                                      | External SMPTE is enabled   |

When the console detects SMPTE data, it will automatically run the SMPTE program. If external data is not detected, and the internal clock is disabled, the message **Waiting for input** appears above the SMPTE list. To run the SMPTE program, start the flow of external SMPTE data.

## Setting SMPTE frame rate

The SMPTE frame rate may be set to 24, 25 or 30 frames per second. 30 frames per second is the default. To change the frame rate, follow these steps.

| Keystrokes:  | Actions:   |
|--|--|
| 1. Press [Setup].  | Selects Setup display  |
| 2. Press [6], <b>Options Settings</b> , and press [Enter]. | Selects Options Settings menu  |
| 3. Press [6], <b>SMPTE Frames Per Second</b> , [Enter].    | Prompt reads: <b>Select SMPTE frames per second, then press ENTER (1 = 30 fps, 2 = 25 fps, 3 = 24 fps)</b> |
| 4. Press [2] [Enter].                                      | SMPTE frame rate is set to 25 fps  |

## Creating SMPTE programs

The console allows you to create SMPTE programs in the SMPTE Events display or in Learn mode.

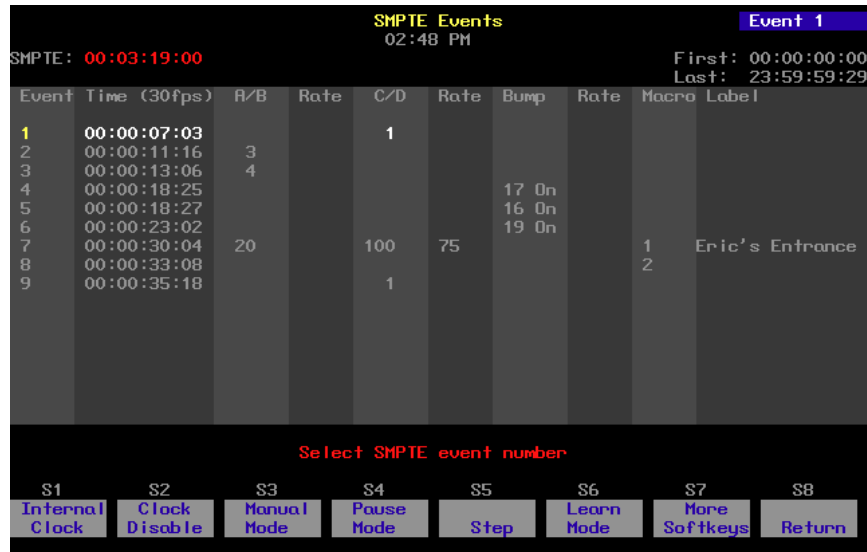

The screenshot shows the SMPTE Events display with the following data:

| Event | Time (30fps) | A/B | Rate | C/D | Rate | Bump  | Rate | Macro | Label           |
|-------|--------------|-----|------|-----|------|-------|------|-------|-----------------|
| 1     | 00:00:07:03  |     |      | 1   |      |       |      |       |                 |
| 2     | 00:00:11:16  | 3   |      |     |      |       |      |       |                 |
| 3     | 00:00:13:06  | 4   |      |     |      |       |      |       |                 |
| 4     | 00:00:18:25  |     |      |     |      | 17 0n |      |       |                 |
| 5     | 00:00:18:27  |     |      |     |      | 16 0n |      |       |                 |
| 6     | 00:00:23:02  |     |      |     |      | 19 0n |      |       |                 |
| 7     | 00:00:30:04  | 20  |      | 100 | 75   |       |      | 1     | Eric's Entrance |
| 8     | 00:00:33:08  |     |      |     |      |       |      | 2     |                 |
| 9     | 00:00:35:18  |     |      | 1   |      |       |      |       |                 |

Additional information from the screenshot:

- SMPTE: 00:03:19:00
- SMPTE Events 02:48 PM
- Event 1 (highlighted)
- First: 00:00:00:00
- Last: 23:59:59:29
- Select SMPTE event number
- Control panel buttons: S1 Internal Clock, S2 Clock Disable, S3 Manual Mode, S4 Pause Mode, S5 Step, S6 Learn Mode, S7 More Softkeys, S8 Return

In the SMPTE Events display, use the four arrow keys to move the yellow highlight around the screen. Press [←] or [→] to move the highlight horizontally. Press [↑] or [↓] to move the highlight vertically. When you reach the right end of a line, pressing [→] moves to the next line. When you reach the last line, press [↓] and enter a new time to add a new SMPTE event.

*Hint: If you are creating a series of similar SMPTE events you may find it helpful to create one event, then copy it. See Copying SMPTE events on page 253 for more information.*

## ***In the SMPTE Edit display***

Follow these steps to create a SMPTE program from the SMPTE Events display:

| <b>Keystrokes:</b>  | <b>Actions:</b>   |
|---|---|
| 1. Record the cues, submasters and macros you want to include in the program.   |   |
| 2. Press [Setup].   | Selects Setup display   |
| 3. Press [1][3], <b>SMPTE Events</b> , and press [Enter] [Enter].   | Selects SMPTE Events display<br>Prompt reads:<br><b>Select SMPTE Time<br/>(Press TIME to edit specific fields)</b>  |
| 4. Enter [1][0][0].   | Selects one second as the time of the first SMPTE event you want to create  |
| 5. Press [→].   | Highlight moves to the <b>A/B</b> field<br>Prompt reads:<br><b>Select SMPTE A/B Cue</b>   |
| 6. Press [1].   | Enters cue 1 for event 1 to play on the A/B fader   |
| 7. Press [→].   | Highlight moves to the Rate field<br>Prompt reads:<br><b>Select SMPTE A/B Rate<br/>(0 to 2000, 100 = Normal)</b>  |
| 8. Press [1][2][5]. (Zero stops the fade. 100 is normal. With fade rate set at 50, cue runs at half its recorded rate. If no rate is entered, the cue runs at its recorded rate.) | Enters a rate of 125 percent of the recorded fade rate<br>Corner reads:<br><b>Rate 125</b>  |
| 9. Press [→].   | Highlight moves to the <b>C/D</b> field<br>Prompt reads:<br><b>Select SMPTE C/D Cue</b>   |
| 10. Repeat steps 6 through 8 for fader C/D.   |   |
| 11. Press [→].  | Moves the highlight to the <b>Bump</b> field<br>Prompt reads:<br><b>Select submaster number for SMPTE bump event, then press [+] for ON, or [-] for OFF</b> |
| 12. Enter the desired submaster number, then press [+] to set the submaster On, or [-] to set the submaster off.  |   |
| 13. Press [→] to move the highlight to the submaster <b>Rate</b> field.   | Prompt reads:<br><b>Select SMPTE Bump Rate<br/>(0 to 2000, 100 = normal)</b>  |

14. Press [→].  
Leaves fade rate at normal and moves the highlight to the **Macro** field  
Prompt reads:  
**Select SMPTE Macro**
15. Press [5].  
Selects macro 5 to run when event plays
16. Press [→].  
Moves the highlight to the **Label** field  
Prompt reads:  
**Enter SMPTE Label**
17. Use an alphanumeric keyboard to enter a name for the event.
18. Press [↓] and enter the SMPTE time to create the next event  
Prompt reads:  
**Select SMPTE Time (Press TIME to edit specific fields)**
19. Repeat steps 4 through 18 until you have entered all your SMPTE events.

## In Learn mode

SMPTE Learn mode allows you to record macro keys, submaster bump buttons and fader [Go] keys into SMPTE events as you press them. Learn mode allows you to record a SMPTE program live without concerning yourself with SMPTE time.

*Warning: If you use Learn to assign a cue to fader in which a cue already exists, the previously recorded cue will be overwritten by the new cue.*

Follow these steps to record a SMPTE event in Learn mode:

| <b>Keystrokes:</b>   | <b>Actions:</b>  |
|--|--|
| 1. Press [Setup].  | Selects Setup display  |
| 2. Press [1][3], <b>SMPTE Events</b> , and press [Enter].  | Selects SMPTE Events display mode  |
| 3. Press [S7], until [S6] reads <b>Learn Mode</b> .  |  |
| 4. Press [S6], <b>Learn Mode</b> .   | <b>SMPTE Learn</b> flashes in red in the upper left corner of the screen                 |
| 5. If you are going to use the internal clock to time the show, press [S2], <b>Clock Enable</b> , to start the clock.  | The SMPTE internal clock, in the upper left corner of the display, starts to run         |
| 6. Press [Stage].  | Selects Stage display  |
| 7. If you are going to use external SMPTE to time the show, start SMPTE data flow now. The SMPTE port must have been enabled before you do this. See <i>External SMPTE source</i> on page 257 for details.                   |  |
| 8. Select the cues, submasters and macros you want to record as SMPTE events.  |  |
| 9. At the exact moment in the program that you want each cue, submaster or macro to begin, press [Go] for the fader in which you want the SMPTE event to run the cue, press the submaster's bump button, or start the macro. | Each button press is recorded as an event in your SMPTE show                             |
| 10. Press [Setup] [1][3] [Enter] [S6], <b>Learn Mode</b> .   | Returns to SMPTE Events display and deactivates Learn mode; edit the events as necessary |

*Note: You may also enter events using Learn mode in the SMPTE Events display. From this display, while in Learn mode, press [Record] to enter a blank event.*

## **Reset Loop time**

The SMPTE program loop plays from the first event time to the last event time, then resets and plays again. The first and last times are displayed in the upper right corner of the display, and may be set by the user. Any events with SMPTE times before the first time or after the last time will not play.

*Note: A SMPTE loop can last from five seconds up to 24 hours. If the loop is set to be less than five seconds, the internal clock resets it to five seconds from the loop's starting time.*

To set or change the first and last event times, follow these steps:

| <b>Keystrokes:</b>  | <b>Actions:</b>  |
|---|--|
| 1. Press [Setup].   | Selects Setup display  |
| 2. Press [1][3], <b>SMPTE Events</b> , and press [Enter]. | Selects SMPTE Events display mode  |
| 3. Press [S7] until [S8] reads <b>Reset Loop</b> .        |  |
| 4. Press [S8], <b>Reset Loop</b> .                        | Prompt reads:<br><b>Enter first valid frame of SMPTE internal time, then press ENTER. (Press TIME to edit specific fields)</b> |
| 5. Press [1][0][0][0]                                     | Sets ten seconds as the starting time for the SMPTE show   |
| 6. Press [Enter].   | Prompt reads:<br><b>Enter last valid frame of SMPTE internal time, then press ENTER. (Press TIME to edit specific fields)</b>  |
| 7. Press [5][0][0][0][0] then press [Enter].              | Sets the SMPTE show to reset at the five minute mark   |

## Editing SMPTE programs

Once you have created a SMPTE program, you can easily make changes. In the SMPTE edit display, use the arrow keys to move the highlight around in the display screen. Press [←] or [→] to move the highlight horizontally. Press [↑] or [↓] to move the highlight vertically. When you reach the right end of a line, press [→] to move to the next line. When you reach the last line, press [↓] and enter a time to add a new SMPTE event.

### Editing Features

The console's SMPTE editing features allow you to Insert, Copy, Move, and Delete events. You may apply these functions to individual events, or to a range of events.

### Deleting SMPTE events

Follow these steps to delete SMPTE events.

| Keystrokes:  | Actions:  |
|--|---|
| 1. Press [Setup].  | Selects Setup display   |
| 2. Press [1][3], <b>SMPTE Events</b> , and press [Enter].              | Selects SMPTE Events display mode   |
| 3. Press [S7] until [S6] reads <b>Delete Event</b> .                   |   |
| 4. Press [S6], <b>Delete Event</b> .                                   | Prompt reads:<br><b>Select event number(s) to delete, then press ENTER</b><br><b>To cancel, press CLEAR</b>         |
| 5. Press [5] [And] [6] [Enter].  | Enters events 5 and 6 to delete<br>Prompt reads:<br><b>To confirm, press ENTER</b><br><b>To cancel, press CLEAR</b> |
| 6. Press [Enter] to delete the event or [Clear] to leave it unchanged. |   |

*Note: The **Clear SMPTE Events** menu option on the Clear menu allows you to delete all recorded SMPTE events. To do so, press [Setup] [4] [Enter] [1][3] [Enter] [Enter].*

## ***Inserting SMPTE events***

To add a new SMPTE event to an existing SMPTE program, follow these steps:

| <b>Keystrokes:</b>   | <b>Actions:</b>  |
|--|--|
| 1. Press [Setup].  | Selects Setup display  |
| 2. Press [1][3], <b>SMPTE Events</b> , and press [Enter].                                  | Selects SMPTE Events display mode  |
| 3. Use the arrow keys to select event 4. The new event will be inserted before this event. | Corner reads:<br><b>Event 4</b>  |
| 4. Press [S7] until [S1] reads <b>Insert Event</b> .                                       |  |
| 5. Press [S1], <b>Insert Event</b> .   | Prompt reads:<br><b>Select event number to insert, then press ENTER</b><br><b>To cancel, press CLEAR</b>     |
| 6. Press [Enter].  | Prompt reads:<br><b>Select number of events to insert, then press ENTER</b><br><b>To cancel, press CLEAR</b> |
| 7. Press [2].  | Indicates that you wish to insert two new events<br>Corner reads:<br><b>Insert 2</b>                         |
| 8. Press [Enter].  | New events 4 and 5 are inserted; all following events are renumbered   |

## ***Copying SMPTE events***

Allows you to copy the selected event or range of events from one time slot and insert the copy in another. Follow these steps to copy SMPTE events:

### **Keystrokes:**

1. Press [Setup].
2. Press [1][3], **SMPTE Events**, and press [Enter].
3. Press [S7] until [S2] reads **Copy Event**.
4. Press [S2], **Copy Event**.
5. Press [1] [Thru] [5].
6. Press [Enter].
7. Press [Time] [Time] [2][5].
8. Press [Enter].

### **Actions:**

- Selects Setup display
- Selects SMPTE Events display mode
- Prompt reads:  
**Select event number(s) to copy, then press ENTER. To cancel, press CLEAR**
- Selects events 1 through 5 to copy
- Prompt reads:  
**To copy selected event(s), select time and press ENTER. To cancel, press CLEAR**
- Selects 25 seconds for the first event to copy
- Copies event 1 to a new event starting at 25 seconds; the rest of the events maintain their original relationship in time

## **Moving SMPTE events**

The system allows you to move one or more SMPTE events from one time slot to another. Follow these steps to move a block of SMPTE events.

| <b>Keystrokes:</b>  | <b>Actions:</b>  |
|---|--|
| 1. Press [Setup].   | Selects Setup display  |
| 2. Press [1][3], <b>SMPTE Events</b> , and press [Enter]. | Selects SMPTE Events display mode  |
| 3. Press [S7] until [S3] reads <b>Move Event</b> .        |  |
| 4. Press [S3], <b>Move Event</b> .                        | Prompt reads:<br><b>Select event number(s) to move, then press ENTER</b><br><b>To cancel, press CLEAR</b>                            |
| 5. Press [1] [Thru] [5].                                  | Selects events 1 through 5 to move   |
| 6. Press [Enter].   | Prompt reads:<br><b>To move selected event(s), select time and press ENTER. To cancel, press CLEAR</b>                               |
| 7. Press [Time] [Time] [Time] [5].                        | Selects five minutes for the first event to move   |
| 8. Press [Enter].   | Copies event 1 to a new event starting at the five minute point; the rest of the events maintain their original relationship in time |

*Note: To move a single event, you may also use the arrow keys to highlight the SMPTE time for the event you want to move, then press [+] or [-] until the new SMPTE time is displayed in the keypad prompt window, and press [Enter]. Or, use the keypad to enter the new time, then press [Enter]. The event will move to the new time when you sort the event list or leave the SMPTE editing screen.*

## Editing events

Each event in a SMPTE program may contain a combination of cues, macros and submaster bump buttons. Each of the cues and submasters may have a rate applied, and the event may be labeled for easy identifications. You may add, change or delete any of these items from an event by following these steps.

### Keystrokes:

1. Press [Setup].
2. Press [1][3], **SMPTE Events**, and press [Enter].
3. Use the arrow keys to highlight the field of the item you want to edit.
4. Enter the new contents of the field. If you wish to delete the item, press [Clear].
5. Press [Enter], or use the arrow keys to select another field.

### Actions:

- Selects Setup display
- Selects SMPTE Events display mode
- Selects field to edit

## Range editing

If you wish to apply a change to a range of events, you may select multiple events and edit them all in a single step. For example, if you wanted to set the rates for your first ten events to 50 percent, you could do so by following these steps:

### Keystrokes:

1. Press [Setup].
2. Press [1][3], **SMPTE Events**, and press [Enter].
3. Press [S7] until [S1] reads **Select Event**.
4. Press [S1], **Select Event**.
5. Press [1] [Thru] [1][0].
6. Press [S4], **Rate**.
7. Press [5][0].
8. Repeat steps 6 and 7 for the remaining rate fields.

### Actions:

- Selects Setup display
- Selects SMPTE Events display mode
- Prompt reads:  
**Select SMPTE event number**
- The first rate field is highlighted  
Prompt reads:  
**Select SMPTE A/B Rate**
- Sets the rate to 50 percent

Or, for example, if you wanted to move ten events five seconds later in order to insert a new event into the middle of a program, you could do so by following these steps:

**Keystrokes:**

1. Press [Setup].
2. Press [1][3], **SMPTE Events**, and press [Enter].
3. Press [S7] until [S1] reads **Select Event**.
4. Press [S1], **Select Event**.
5. Press [1][1] [Thru] [2][0].
6. Press [S2], **SMPTE Time**.
7. Press [Time] [Time].
8. Press [+] five times.
9. Press [Enter].

**Actions:**

- Selects Setup display
- Selects SMPTE Events display mode
- Prompt reads:  
**Select SMPTE event number**
- The time field is highlighted  
Prompt reads:  
**Select SMPTE Time (Press TIME to edit specific fields)**
- Selects the seconds field for all ten events  
Prompt reads:  
**Select SMPTE seconds**
- Each time you press [+], the seconds field for each event increases by one second
- Sets the new times

## Playing back the SMPTE program

The console allows you to play recorded SMPTE events in several ways. You may use any external source of SMPTE data to run the program, you may run the program using the console's built-in SMPTE clock, or you may play individual events manually.

*Note: As you play back SMPTE programs, you may find it useful to display the SMPTE event list on the playback display. To do so, press [Setup] [6] [Enter] [7] [Enter] [1] [Enter].*

### External SMPTE source

Once you have recorded a series of cues in a SMPTE program, the console automatically runs the program in response to SMPTE time code. To run the SMPTE program, start the flow of external SMPTE data.

Before you start SMPTE flow, you must enable the SMPTE port. To do so, follow these steps:

| <b>Keystrokes:</b>   | <b>Actions:</b>   |
|--|---|
| 1. Press [Setup].  | Selects Setup display   |
| 2. Press [6], <b>Options Settings</b> , and press [Enter]. | Selects Options Settings menu   |
| 3. Press [5], <b>SMPTE Input</b> , [Enter].                | Prompt reads:<br><b>Enable/disable external SMPTE input (1 = Enable, 2 = Disable)</b> |
| 4. Press [1] [Enter].                                      | External SMPTE is enabled   |

When the console detects SMPTE data, it will automatically run the SMPTE program. If external data is not detected, and the internal clock is disabled, the message **Waiting for input** appears above the SMPTE list.

## ***Internal SMPTE clock***

To run the SMPTE program using the internal clock, follow these steps:

### **Keystrokes:**

1. Press [Setup].
2. Press [1][3], **SMPTE Events**, and press [Enter].
3. Press [S1], **Internal Clock**.
4. Use the keypad or the [+] and [-] keys to enter the SMPTE time of the first event you want to view, or enter zero to start at the beginning of the SMPTE program.
5. Press [Enter].
6. Press [S2], **Clock Enable**, to start the internal clock running at the desired SMPTE time.

### **Actions:**

- Selects Setup display
- Selects SMPTE Events display mode
- Prompt reads:  
**Set SMPTE internal clock, then press ENTER (Press TIME to edit specific fields)**
- Each SMPTE event will run at its recorded time

## Manual playback

The Manual Mode, Pause Mode, and Step softkeys allow you to manually control playback of SMPTE events with no external SMPTE time input and without the console's internal clock. [Time] allows you to select an event by specifying its SMPTE time.

Follow these steps to select and run SMPTE events out of recorded sequence.

| Keystrokes:   | Actions:   |
|---|--|
| 1. Press [Setup].   | Selects Setup display  |
| 2. Press [1][3], <b>SMPTE Events</b> , and press [Enter].   | Selects SMPTE Events display mode  |
| 3. Press [S3], <b>Manual Mode</b><br>or...<br>Press [S4], <b>Pause Mode</b> ,   | Interrupts SMPTE input and resets the console to the first recorded SMPTE event,<br>or...<br>Interrupts SMPTE input at current SMPTE event |
| 4. Press [S5], <b>Step</b> .  | Advances to the next recorded SMPTE event, (In Manual mode, pressing [Step] starts with the first recorded SMPTE event)                    |
| 5. Repeat step 4 to advance sequentially through SMPTE events.  |  |
| 6. If you are in Manual mode, press [S3], <b>Manual Mode</b> .<br>If you are in Pause mode, press [S4], <b>Pause Mode</b> . | Returns to normal operation and the flow of SMPTE code resumes   |

*Note: Always press [S3], **Manual Mode**, or [S4], **Pause Mode**, to interrupt SMPTE code when you are programming the console. This prevents SMPTE events from running while you are working.*

## **Remote macros**

The Remote macro feature provides the ability to access up to 8 macros from locations up to 1000 feet from the main console. Typically the Remote Macro control device is an eight button control station.

The remote macro outputs control macros 1,901 through 1,908. To run one of these macros from a remote location, press the appropriate control.

ETC does not provide remote macro units. However, the console does provide a 25-pin connector labeled **Remote Go** to which you may attach a user-supplied, remote macro control device. See *Installing remote macros* on page 302 for more information about installing remote macros.

*Note: The Insight 2 Lighting Playback Controller provides four Remote Macro connectors, for a total of 32 remote macros. These are each equivalent to the single connector described above. These remote macro outputs control macros 1,901 through 1,932.*

# chapter 22

## park

This chapter includes instructions for using Insight 2's Park function. Park allows you to set channels or dimmers at a level and maintain those lights at that level on stage, regardless of other instructions. Parked channel and dimmer levels are not affected by any other instructions and will not be recorded into cues.

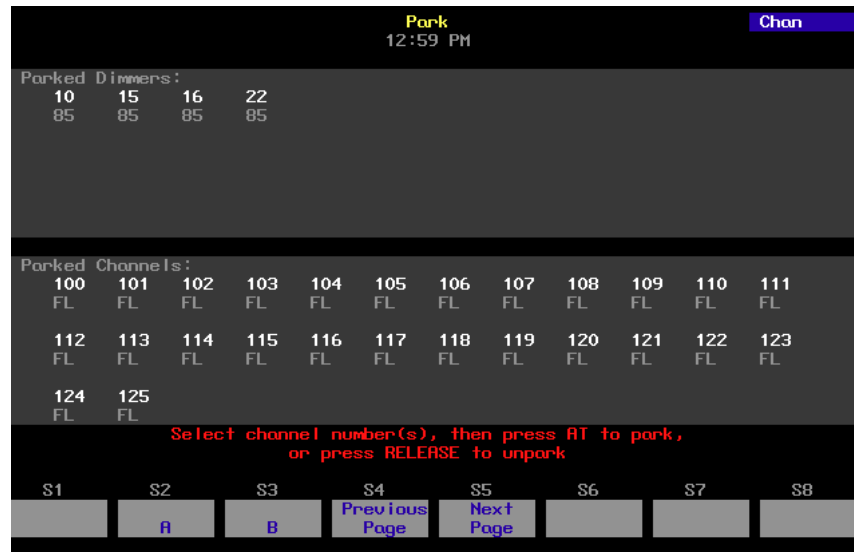

*Note: [Blackout] will turn off parked dimmers and channels unless they are independent channels. Nothing else affects a parked dimmer or channel's level.*

The following options are described in this chapter:

- Parking dimmers
- Unparking dimmers
- Parking channels
- Unparking channels
- Parking groups, cues and submasters
- Park display

## ***Parking dimmers***

To park a dimmer, indicate the dimmer you want to park and the level at which to park it. Once it is parked, nothing you do at the console will have any effect on that light (except for [Blackout]) until you unpark the dimmer. When dimmers are parked, the monitor displays a message at the top of the display that says **Park Enabled**.

To park a dimmer, follow these steps:

| <b>Keystrokes:</b>                                   | <b>Action:</b>   |
|--|--|
| 1. Press [Stage].                                    | Selects Stage display  |
| 2. Press [S6], <b>Park</b> , [Dim].                  | Prompt reads:<br><b>Select dimmer number(s), then press AT to park, or press RELEASE to unpark</b> |
| 3. Enter the dimmer number to park, then press [At]. | Selects the dimmer to park<br>Prompt reads:<br><b>Enter intensity for park dimmer(s)</b>           |
| 4. Enter the level at which to park the dimmer.      | Parks the dimmer at the selected level<br>Alert appears:<br><b>Parked Dimmers</b>                  |

## ***Unparking dimmers***

You may unpark one or all dimmers at any time. When a dimmer is unparked, its level reverts to the level the console is currently assigning it.

### ***Unpark a dimmer***

To unpark a dimmer, follow these steps:

| <b>Keystrokes:</b>                                    | <b>Action:</b>   |
|---|--|
| 1. Press [Stage].                                     | Selects Stage display  |
| 2. Press [S6], <b>Park</b> , [Dim].                   | Prompt reads:<br><b>Select dimmer number(s), then<br/>press AT to park, or press RELEASE<br/>to unpark</b> |
| 3. Enter the dimmer number to unpark and press [Rel]. | Unparks the dimmer   |

### ***Unpark all dimmers***

To unpark all parked dimmers, follow these steps:

| <b>Keystrokes:</b>                  | <b>Action:</b>   |
|-------------------------------------|--|
| 1. Press [Stage].                   | Selects Stage display  |
| 2. Press [S6], <b>Park</b> , [Dim]. | Prompt reads:<br><b>Select dimmer number(s), then<br/>press AT to park, or press RELEASE<br/>to unpark</b> |
| 3. Press [Rel].                     | Prompt reads:<br><b>To release all parked dimmers,<br/>press ENTER<br/>To cancel, press CLEAR</b>          |
| 4. Press [Enter].                   | Unparks all parked dimmers   |

## Parking channels

To park a channel, indicate the channel you want to park and the level at which to park it. Once it is parked, nothing you do at the console will have any effect on lights in that channel (except for [Blackout]) until you unpark the channel. When channels are parked, the monitor displays a message at the top of the display that says **Park Enabled**.

*Note: If a dimmer is parked and the channel that controls it is also parked, the dimmer's parked level takes priority over the channel's parked level. If the dimmer is then unparked, it will revert to the channel's parked level.*

To park a channel, follow these steps:

| <b>Keystrokes:</b>                                    | <b>Action:</b>  |
|---|---|
| 1. Press [Stage].                                     | Selects Stage display   |
| 2. Press [S6], <b>Park</b> .                          | Prompt reads:<br><b>Select channel number(s), then press AT to park, or press RELEASE to unpark</b> |
| 3. Enter the channel number to park, then press [At]. | Selects the channel to park<br>Prompt reads:<br><b>Enter intensity for park channel(s)</b>          |
| 4. Enter the level at which to park the channel.      | Parks the channel at the selected level<br>Alert appears:<br><b>Parked Channels</b>                 |

## Unparking channels

You may unpark one or all channels at any time. When a channel is unparked, its level reverts instantly to whatever level the console is currently assigning it.

### Unpark a channel

To unpark a channel, follow these steps:

| Keystrokes:  | Action:   |
|--|---|
| 1. Press [Stage].                                      | Selects Stage display   |
| 2. Press [S6], <b>Park</b> .                           | Prompt reads:<br><b>Select channel number(s), then press AT to park, or press RELEASE to unpark</b> |
| 3. Enter the channel number to unpark and press [Rel]. | Unparks the channel   |

### Unpark all channels

To unpark all parked channels, follow these steps:

| Keystrokes:                  | Action:   |
|------------------------------|---|
| 1. Press [Stage].            | Selects Stage display   |
| 2. Press [S6], <b>Park</b> . | Prompt reads:<br><b>Select channel number(s), then press AT to park, or press RELEASE to unpark</b> |
| 3. Press [Rel].              | Prompt reads:<br><b>To release all parked channels, press ENTER. To cancel, press CLEAR</b>         |
| 4. Press [Enter].            | Unparks all parked channels   |

## ***Parking groups, cues and submasters***

Groups, cues and submasters are collections of channels with associated control instructions. Insight 2 allows you to park the channels used in groups, cues and submasters at a specified level, ignoring their recorded levels. For example, if all your worklights are recorded in a group, you could park that group, rather than parking all of the worklight channels individually.

### ***Park a group***

To park the channels in a group, follow these steps:

| <b>Keystrokes:</b>                                       | <b>Action:</b>  |
|--|---|
| 1. Press [Stage].  | Selects Live display  |
| 2. Press [S6], <b>Park</b> , [Group].                    | Prompt reads:<br><b>Group mode - Select group number, then press AT to park, or press Release to unpark</b> |
| 3. Enter the group number and press [At].                | Selects the group to park<br>Prompt reads:<br><b>Group mode - Enter intensity</b>                           |
| 4. Enter the level at which to park the group's channel. | Parks the channels at the selected level  |

### ***Park a cue or submaster***

To park the channels used in a cue or submaster follow these steps, pressing either [Cue] or [Sub], respectively, in step 2:

| <b>Keystrokes:</b>                                     | <b>Action:</b>  |
|--|---|
| 1. Press [Stage].                                      | Selects Live display  |
| 2. Press [S6], <b>Park</b> , [Cue].                    | Prompt reads:<br><b>Group mode - Select cue number to use as group, then press AT to park, or press Release to unpark</b> |
| 3. Enter the cue number and press [At].                | Selects the cue to park<br>Prompt reads:<br><b>Group mode - Enter intensity</b>   |
| 4. Enter the level at which to park the cue's channel. | Parks the channels at the selected level  |

## ***Unpark a group, cue or submaster***

To unpark the channels in a group, cue or submaster, follow these steps, pressing [Group], [Cue] or [Sub], respectively, in step 2:

### **Keystrokes:**

1. Press [Stage].
2. Press [S6], **Park**, [Group].
3. Enter the group number to unpark and press [Rel].

### **Action:**

Selects Stage display

Prompt reads:

**Group mode - Select cue number to use as group, then press AT to park, or press Release to unpark**

Unparks the group's channels

## Park display

Press [Park] to bring up the Park display. The Park display lists parked dimmers on the top half of the screen, and parked channels on the lower half, along with their parked levels.

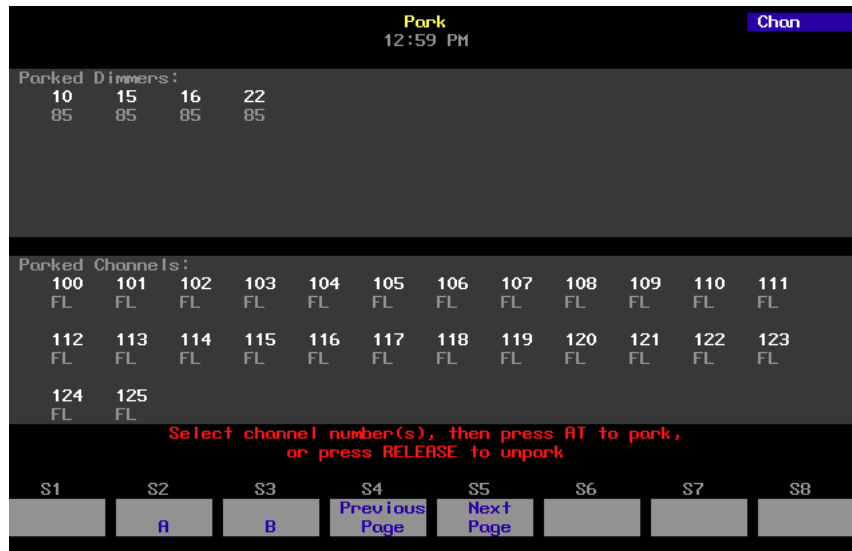

The Park display can show up to 36 dimmers and 36 channels. If you have more than 36 dimmers or channels parked, use [S4], **Previous Page**, and [S5], **Next Page**, to move through the Park display lists a page at a time. You can also move directly to a channel or dimmer in the list by entering the channel number and pressing [At] or by pressing [Dim], entering the dimmer number, and pressing [At].

# appendix a

## installation

This appendix includes instructions for installing your console and optional accessories. *Chapter 3, Entering system settings*, and *Chapter 4, Creating patch*, include instructions for entering the software settings you will probably update before you begin a new show.

This chapter includes the following installation procedures:

- Installing your console
- Installing your monitor
- Connecting your dimmers
- System configuration
- Installing the alphanumeric keyboard
- Installing a printer
- Installing Designer's Worksheet
- Installing Remote Focus Unit
- MIDI
- SMPTE
- ETCNet
- Installing remote video monitors
- Installing Infrared Remote Focus Unit (IRFU)
- Installing Remote Macros

An illustration of Insight 2's back panel is included on the next page. Operating instruction for optional accessories are included in *Chapter 18, Accessories*.

## Insight 2 back panel

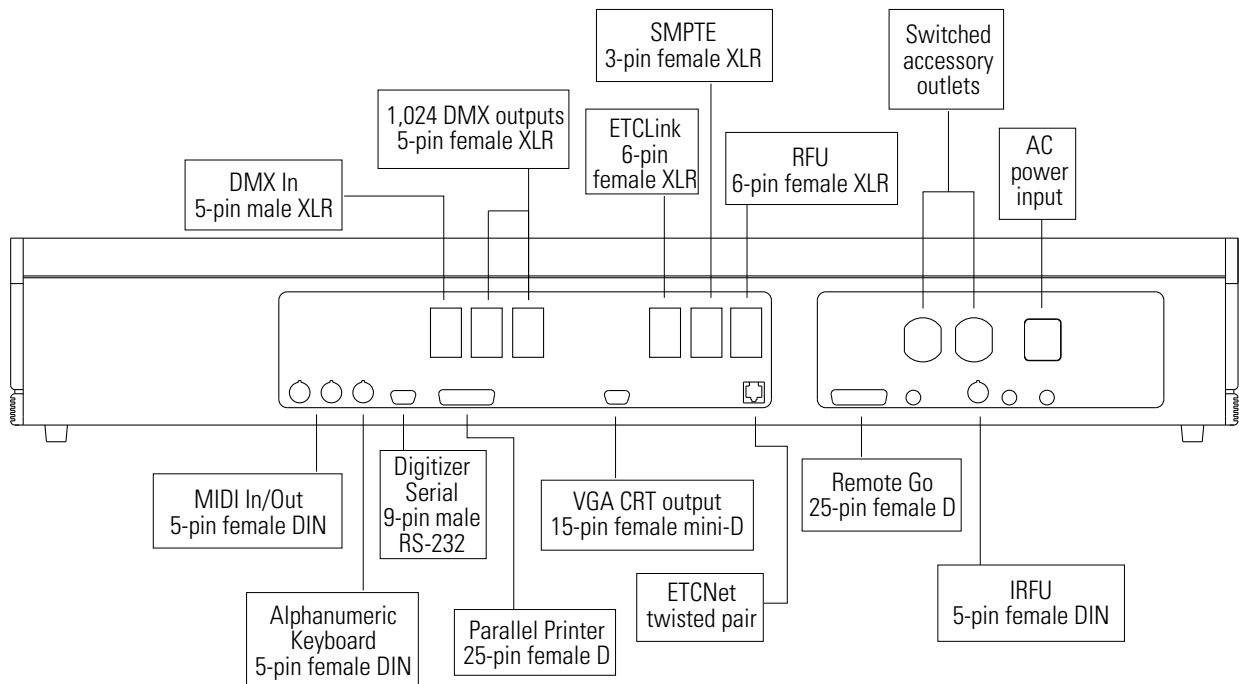

## ***DIP switches and jumpers***

Several components of the Insight 2 system contain DIP switches which must be set properly in order for the system to function properly. The DIP switch settings for the following components are listed in this appendix, along with instructions for changing them. New DIP switch settings take effect when you turn on the console.

### ***Setting DIP switches***

Insight 2 checks DIP switch settings when the system is turned on. You must restart the console for new DIP switch settings to take effect.

Switches are either **On (Closed)** or **Off (Open)**. Two varieties of DIP switch are used in the Insight 2. In one, the switches extend above the surface of the unit. You may use your fingers to set these switches. The other contains switches that are recessed into the unit. You will need to use a pin or other fine-pointed object to change the switch settings.

### ***Setting jumpers***

A jumper is a small plastic connector used to join a pair of pins sticking out of a printed circuit board. The jumper is installed when it covers both pins. It is not installed when it covers one or none of the pins (see illustration below).

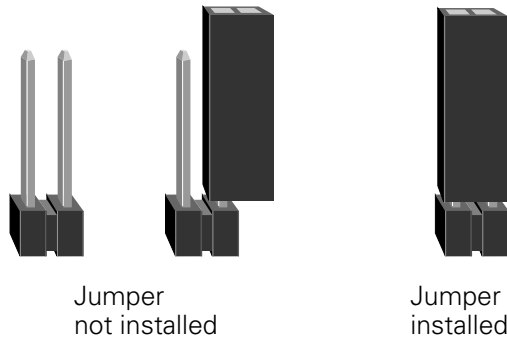

# Circuit boards

Insight 2 components use one of two main circuit boards. Consoles contain a Main Processor board (part 4031B4006). Remote Interfaces contain a Node board (part 4052B4014). The circuit board may be identified by the part number and revision printed on the board. Illustrations of the two boards follow.

## Main Processor Board - Revision 0 or B

The Revision 0 or Revision B Main Processor Board appears in the console. It contains one 8-switch DIP switch unit.

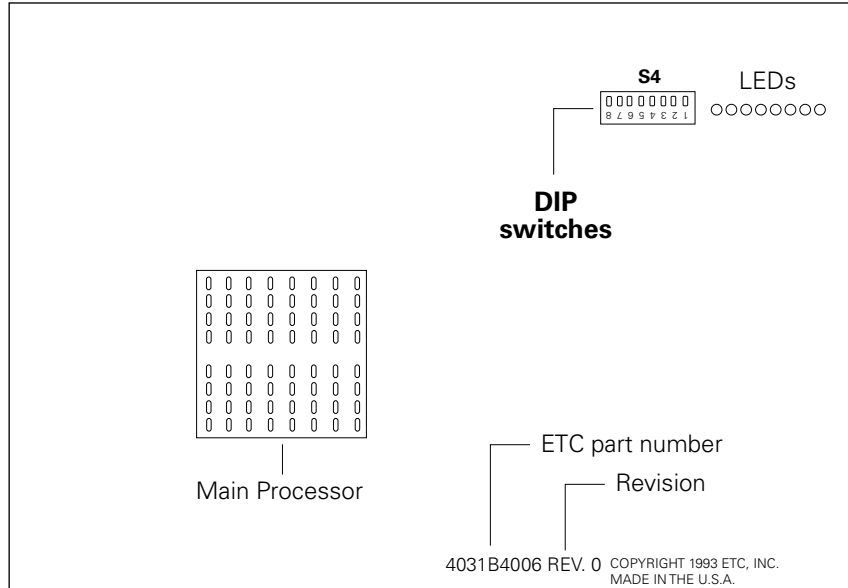

## Node Board - Revision A

The Revision A Node Board appears in Remote Interfaces. It contains one 8-switch DIP switch unit and a set of 14 jumpers.

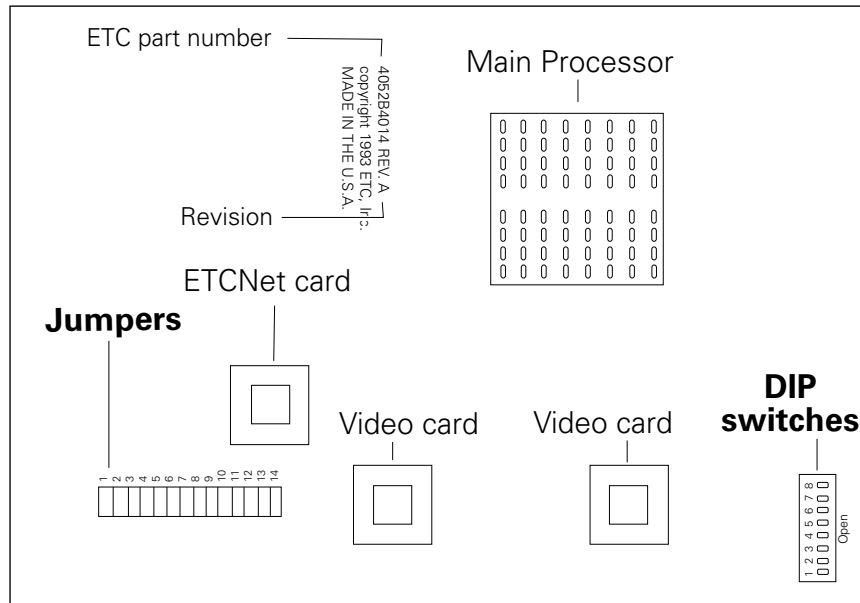

Before you use the device on the ETCNet network, set the ETCNet cabling jumpers to indicate what kind of cable the network uses. To set the jumpers, follow these steps.

1. Locate jumpers 1 through 14. (See illustration above.)
2. If your network cable is plugged into the BNC connector (ThinNet), install jumpers 1 through 6. Be certain jumpers 7 through 12 are not installed.
3. If your network cable is plugged into the RJ45 connector (Twisted Pair) or the DB15 connector (ThickNet), install only jumpers 7 through 12. Be certain jumpers 1 through 6 are not installed.
4. Jumper 13 must always be off. Jumper 14 should always be installed.

# Installing console and monitor

Follow these steps to install Insight 2 and its monitor:

1. Place console on a hard, stable, flat surface. Leave at least six inches of space behind console for ventilation and cable clearance. Console should be at least six feet from dimmers and high-current AC lines.

*Caution: Do not leave the console in a road case tray or on a soft surface. This will inhibit proper ventilation.*

2. Move console power switch (by fan on back panel) to the **Off** position. (Older consoles may have a keyswitch power switch on the face panel. If so, insert the key into the power switch, and turn it to the **Off** position.)
3. Connect the video cable from the monitor to the appropriate console connector labeled **CRT 1** on the back panel.
4. Insert the female end of the console power cord in the connector labeled **Power in** on the console's back panel.
5. Insert the female end of the monitor power cord in the connector on the back of the monitor.
6. Insert the male end of the monitor power cord in the console connector labeled **Switched AC Outlets**. The switched AC outlets provide the same voltage the console is plugged into.
7. Insert the male end of the console power cord in a grounded 120 VAC outlet. For 220 VAC operation, consult ETC.

## **VGA monitor console connector**

HD-DB15 female

## **VGA monitor pinout**

- 1 Red video
- 2 Green video
- 3 Blue video
- 4 Ground
- 5 Ground
- 6 Red ground
- 7 Green ground
- 8 Blue ground
- 9 not connected
- 10 Ground
- 11 Ground
- 12 not connected
- 13 H. (H/V) sync
- 14 V. sync
- 15 not connected

*Note: In some installations you may need additional grounding. An additional grounding location is provided on the rear of the console for this purpose. This console is not certified for use in wet locations.*

## Older console DIP switch settings

A set of DIP switches are located inside older consoles (with keyswitch style power switches) at the back right corner of the circuit board, to the left of a strip of eight LEDs. The settings of DIP switches 2 and 3 determine whether your system is using ETCNet. DIP switch 4 enables SMPTE.

To change the DIP switch settings, raise the top panel and hold it in upright position. Find the switches and adjust the settings as shown on the list below.

Insight 2 checks DIP switch settings when the console is turned on. You must restart the console for new DIP switch settings to take effect.

Switches are either **On (Closed)** or **Off (Open)**. DIP switches 1, 5, 6, 7, and 8 should always be **Off**.

| <u>DIP Switch</u>                                      | <u>Function</u>  |
|--|--|
| <b>1</b><br>Off (Open)                                 | <b>Factory Use Only</b><br>Should always be set              |
| <b>2</b> <b>3</b><br>Off    Off<br><b>On</b> <b>On</b> | <b>Console mode on start up</b><br>Network off<br>Network on |
| <b>4</b><br>Off (Open)<br><b>On</b> (Closed)           | <b>SMPTE</b><br>SMPTE disabled<br>SMPTE enabled              |
| <b>5 through 8</b><br>Off (Open)                       | <b>Factory Use Only</b><br>Should always be set              |

## Connecting dimmers

These instructions explain how to connect DMX512 outputs and provide DMX512 connector pinout specifications. The Insight 2 console provides two DMX512 output ports, for a total capacity of 1,024 outputs.

Follow these steps to connect dimmers to your console:

1. Verify that your dimmer connector pinout matches the pinout listed below. If your pinout does not match, contact your dealer or ETC.

*Caution: Your dimmer control common must be compatible with console control common; they must either be the same level, or the dimmer control common must float. Verify compatibility with your dealer if you are not sure.*

2. Connect up to two DMX512 cables (1,024 outputs) to DMX512 output connectors on back panel of console. Output connector location is shown on page 272.

### **DMX512 connector**

XLR 5-pin female  
512 digital multiplex dimmers

### **DMX512 pinout**

- 1 Common
- 2 Data (-)
- 3 Data (+)
- 4 not connected
- 5 not connected

## Replacing the auxiliary fuse

If external devices, the RFU, or remote macros fail to operate correctly, and you suspect the console fuse might be the problem, follow these steps to replace the fuse:

1. Turn off the console.
2. Remove the power cord.
3. Using a small flat head screwdriver, gently press and rotate counter-clockwise the fuse holder labeled **RFU/Remote I/O**.
4. Replace the fuse with a fuse of rating T2.5A. Do not use a fuse with any other rating. This is a 2.5 amp 250 V time lag type fuse.

## System configuration

Once your console is installed, you may need to reset some hardware configuration settings. The Input/Output Configuration screen allows you to reset the DMX512 starting numbers for your DMX512 ports, set your ports for ETC Multiplex dimming, and adjust the DMX512 signal speed if your dimming system requires a slower signal.

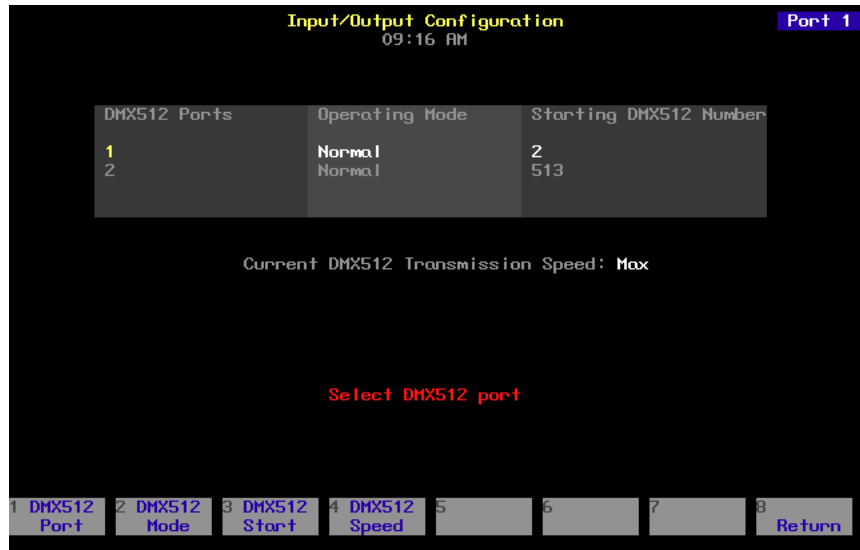

### Setting DMX512 starting numbers

When you install your Insight 2, the console sets the starting dimmer number for DMX512 port 1 to **1** and DMX512 port 2 to **513**. If you prefer, you may set different starting numbers for the DMX512 ports. For example, if your system included 10 racks, each with 96 dimmers, you could set the ports to start at **1** and **481**. This would avoid having any rack receiving signals from two ports. If you do so, you will need to specify this in the I/O Configuration screen.

To reset DMX512 port starting dimmer numbers, follow these steps:

1. Press [Setup] to display the Setup Menu.
2. Press [2], **Input/Output Configuration**, and press [Enter].
3. Press [↓] to select the port to configure (port 1 or 2).
4. Press [S3], **DMX512 Start**.
5. Enter the desired starting number for the port.
6. Press [Enter] twice to confirm your choice.
7. Display indicates port starting number.

## Setting Multiplex mode

If your console is controlling an ETC Sensor dimming system that utilizes ETC's Multiplex dimming, specify this in the I/O Configuration screen.

*Warning: Changing a port to or from Multiplex mode resets your patch.*

To configure your system for the type of fixtures you have, follow these steps:

1. Press [Setup] to display the Setup Menu.
2. Press [2], **Input/Output Configuration**, and press [Enter].
3. Press [S1], **DMX512 Port**, enter the port to configure (port 1 or 2), and press [Enter]. You may also use [↓] to select a port.
4. Press [S2], **DMX512 Mode**.
5. Press [1] to set the port for Multiplex mode or [0] to set the port for normal mode.
6. Press [Enter] twice to confirm your choice.
7. Console indicates mode as either **Normal** or **Multiplex**.

*Note: If you use multiplexed fixtures, you cannot set the ports' starting DMX512 numbers.*

## Setting DMX512 speed

If your console is controlling a dimming system that requires a slower DMX512 signal, specify this in the I/O Configuration screen

Insight 2 is designed to run at the highest rate provided for in DMX512 specifications. Some dimming systems (including some Colortran ENR™ dimmers) may require a signal slower than the full DMX512 specification. If this proves necessary, you may reset the console's signal speed.

Speed choices are **Slow**, **Medium**, **Fast**, and **Max**. Insight 2 normally runs at **Max**. If you have problems with outputs flashing, fades not running smoothly, or unselected dimmers rising spontaneously, experiment with slower speeds until the symptoms disappear. If the symptoms persist, please contact ETC Technical Services at 800/775-4382.

To reset Insight 2's DMX512 signal speed, follow these steps:

1. Press [Setup] to display the Setup Menu.
2. Select 2, **Input/Output Configuration**, and press [Enter].
3. Press [S4], **DMX512 Speed**.
4. Press [0] for **Max**, [1] for **Fast**, [2] for **Medium**, or [3] for **Slow**. The speed you choose appears in the upper right corner of the display.
5. Press [Enter] to confirm your choice.
6. Display indicates new speed setting.

# ***Updating Insight 2 software***

## ***Update procedure***

Insight 2 software updates are distributed on diskette. Follow these steps to update the software in your Insight 2 console. Make sure the diskette is the correct one for your console.

1. Installing new console software clears all system memory. Please save your current show!
2. Turn the console off.
3. Insert the console software diskette into your console's diskette drive.
4. Turn the console back on. The console displays the boot screen and automatically installs the software. This process takes approximately one minute. The console displays the following messages as the installation progresses: **Loading, Erasing Flash, Writing Flash**. Wait until the Stage display appears.
5. Press [Setup] to confirm that the new software has been successfully installed. The current software version is displayed in the lower right corner of the display. This version number should match the number on the diskette. If it does not, repeat the procedure.
6. Press [4] [Enter] [S1], **Reset System**. The update is complete.

## ***Software installation note***

In ETCNet networked systems where an Insight 2 console is connected to Remote Interfaces and/or Remote Video Interfaces, both the console and the remote device must have the same version software installed. For instructions for upgrading remote device software, see *Installing remote unit software* on page 299.

If you have any questions or experience difficulties while upgrading, please call ETC's Technical Services department at 800/775-4382.

## ***Installing an alphanumeric keyboard***

Use the optional keyboard to assign alphanumeric names to cues, sub-masters, groups, effects, and shows.

If you wish to use your own keyboard rather than order one with the console, you can use any standard PC AT compatible alphanumeric keyboard. If the keyboard you use is switchable, use it only in its AT-compatible mode. ETC recommends the Cherry G80-1800 and Keytronic 101 keyboards. Although you may use keyboards from other manufacturers, ETC does not guarantee compatibility.

*Caution: Do not connect or disconnect an alphanumeric keyboard while your system is turned on. Doing so may cause the keyboard to initialize improperly.*

Follow these steps to install an alphanumeric keyboard:

1. Be sure the selector switch is set to the AT position, if applicable.
2. Insert the keyboard cable into the connector labeled **Keyboard** on the Insight 2 or Remote Interface back panel.

### ***Console connector***

DIN 5-pin female

### ***Keyboard pinout***

- 1 Clock
- 2 Data
- 3 Reset
- 4 Ground
- 5 +5 Vdc

## Installing a printer

Insight 2 supports parallel printers, including most laser printers. Printer functions are described in *Chapter 17, Printing*. Follow these steps to install printer:

1. Insert parallel printer cable into connector labeled **Parallel Printer** on the back panel of the console.
2. Insert opposite end of printer cable into printer.
3. Turn printer power switch on, and verify that printer is on line.

### **Console connector** DB25F

| <b>Pinout</b> | <b>Signal</b> |
|---------------|---------------|
| 1             | STRB          |
| 2             | D0            |
| 3             | D1            |
| 4             | D2            |
| 5             | D3            |
| 6             | D4            |
| 7             | D5            |
| 8             | D6            |
| 9             | D7            |
| 10            | ACK           |
| 11            | Busy          |
| 12, 13        | Not used      |
| 14 to 17      | not connected |
| 18 to 25      | Ground        |

### **Printer connector** Centronics D36

| <b>Pinout</b>          |
|------------------------|
| 1                      |
| 2                      |
| 3                      |
| 4                      |
| 5                      |
| 6                      |
| 7                      |
| 8                      |
| 9                      |
| 10                     |
| 11                     |
| 12, 18                 |
| 13 to 15, 17, 19 to 36 |
| 16                     |

# Installing Designer's Worksheet

Designer's Worksheet is a remote digitizer tablet available for use with ETC consoles. Two different models of Kurta digitizers have been used as Designer's Worksheets, and each has a different configuration procedure, described below. Refer to Kurta digitizer tablet documentation if you need additional information. See *Designer's Worksheet* on page 207 for operation instructions.

## Installing the Kurta XGT

The Kurta XGT digitizer tablet is shipped with current Designer's Worksheet systems.

Follow these steps to install and configure your Kurta XGT Designer's Worksheet:

1. Turn off your console or Remote Interface.
2. Plug the 9-pin serial connector on the interface cable into the console or Remote Interface connector labeled **Digitizer**.
3. Plug the other end of the interface cable into the interface connector on the back panel of the XGT. There is a small arrow or dimple on the plug. It should face up.
4. Plug the transformer cable into the DC connector on the interface cable's serial connector (plugged into the back panel of the console or Remote Interface).
5. Plug the transformer into an electrical outlet or a surge protecting power strip.
6. Turn on your console or Remote Interface. The XGT also turns on. The red power on LED in the back left corner should blink off and then on again. If it doesn't, check to be sure all cables are properly connected.
7. The XGT shipped with a page of instructions called *Configuring the Designer's Worksheet for use with Expression 2 line consoles*. Follow the instructions on that page now.
8. The digitizer is now configured properly. Remove the configuration page, store it in a safe place, and place one of the standard ETC template sheets under the clear plastic flap on the digitizer.

*Note: Additional pads of Designer's Worksheet templates are available from your dealer or ETC.*

9. Press [Setup] and select 1, **System Settings**.
10. Press [7], **Designer's Worksheet Setup** [Enter]. Insight 2 displays the Designer's Worksheet Setup Menu.

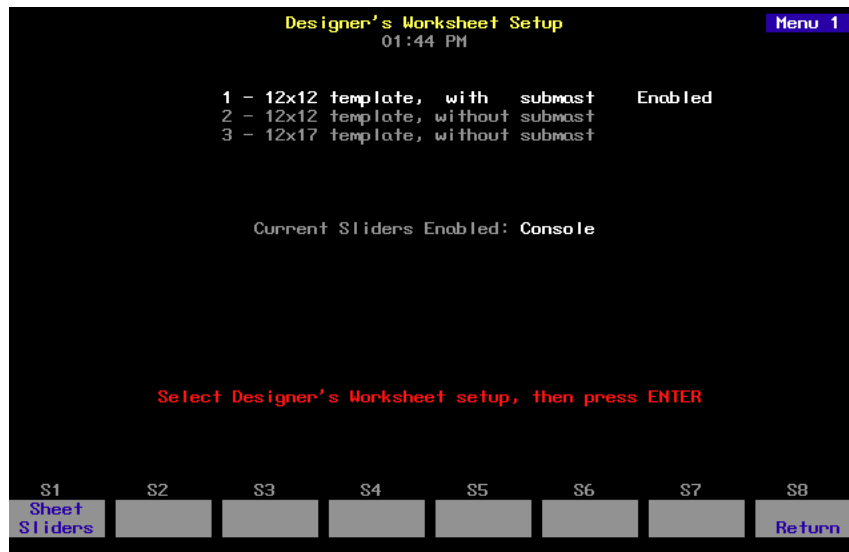

11. Select one of the displayed options, either on the console keypad, or by selecting [F2], [F3], or [F4] on the Worksheet template button bar, then press [Enter].
12. Press [S1], **Sheet/Console Sliders**, to enable slider control from either the digitizer or the console.
13. Touch the pen to the digitizer region labeled **Calibrate** (or [F1]).
14. Follow the instructions on the screen that direct you to touch the pen to the regions labeled **A**, **B** and **C**.

## Installing the Kurta IS/ONE

The Kurta IS/ONE digitizer tablet was shipped with older Designer's Worksheet systems.

Follow these steps to install and configure your Kurta IS/ONE Designer's Worksheet:

1. Insert the 9-pin serial connector of the Designer's Worksheet cable into the console or Remote Interface connector labeled **Digitizer**.
2. Insert the plug end of the pointing device (pen or stylus) in the IS/ONE connector labeled **Pen/Cursor**.
3. Attach the pen holder to the upper left or right hand corner of the Worksheet by removing the protective paper from the base and pressing the adhesive to the tablet.
4. Place one printed template sheet under the clear plastic flap on the digitizer.
5. Set the voltage selection switch to match your electrical outlet. In the US, set the voltage switch to **110**.
6. Plug the power cord into the back of the Worksheet and into an electrical outlet or a surge protecting power strip.

*Note: Additional pads of Designer's Worksheet templates are available from your dealer or ETC.*

7. Set the three sets of DIP switches on the Worksheet as indicated in the chart below.

|              | <b>1</b>    | <b>2</b>    | <b>3</b>    | <b>4</b>    | <b>5</b>    | <b>6</b>    | <b>7</b>  | <b>8</b>    |
|--------------|-------------|-------------|-------------|-------------|-------------|-------------|-----------|-------------|
| <b>Set A</b> | <b>Down</b> | <b>Down</b> | <b>Down</b> | <b>Down</b> | <b>Up</b>   | <b>Up</b>   | <b>Up</b> | <b>Up</b>   |
| <b>Set B</b> | <b>Down</b> | <b>Up</b>   | <b>Down</b> | <b>Up</b>   | <b>Down</b> | <b>Down</b> | <b>Up</b> | <b>Up</b>   |
| <b>Set C</b> | <b>Up</b>   | <b>Up</b>   | <b>Down</b> | <b>Down</b> | <b>Down</b> | <b>Down</b> | <b>Up</b> | <b>Down</b> |

8. Turn the Worksheet power on by pressing the on/off switch. The LED labeled **Indicator** (on the back panel) is lit when power is on. If the LED blinks four times after you turn the power on, the interface cable is not connected correctly.
9. Press [Setup], and select 1, **System Settings**.

- Press [7], **Designer's Worksheet Setup** [Enter]. Insight 2 displays the Designer's Worksheet Setup Menu.

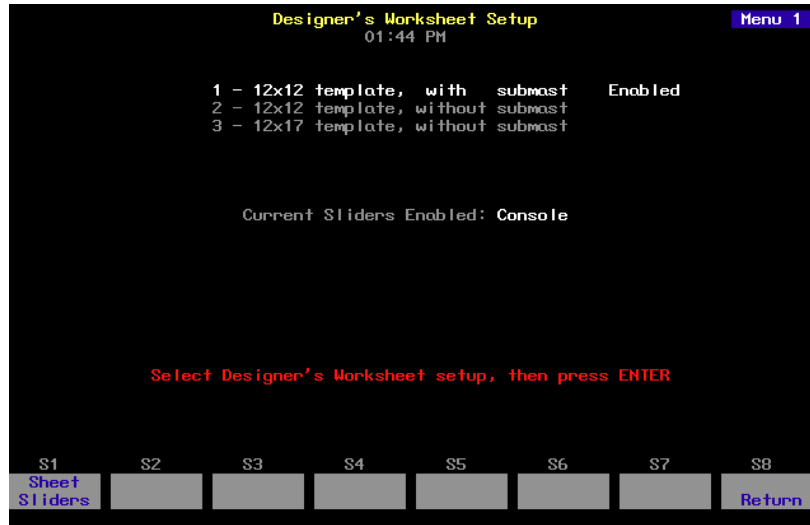

- Select one of the displayed options, either on the console keypad, or by selecting [F2], [F3], or [F4] on the Worksheet template button bar, then press [Enter].
- Press [S1], **Sheet/Console Sliders**, to enable slider control from either the digitizer or the console.
- Touch the pen to the digitizer region labeled **Calibrate** (or [F1]).
- Follow the instructions on the screen that direct you to touch the pen to the regions labeled **A**, **B** and **C**.

### **Designer's Worksheet DIP switch settings**

Three sets of DIP switches are located on the back panel of the Kurta IS/ ONE Designer's Worksheet. These DIP switches need to be set as shown below for the digitizer to function properly. The Kurta XGT Designer's Worksheet does not have DIP switches.

*Note: These settings are different from those used with old Expression-line consoles.*

To change the DIP switch settings, find the switches and adjust the settings as shown on the illustration and chart below.

The Designer's Worksheet checks DIP switch settings when unit is turned on. You must restart the unit for new DIP switch settings to take effect.

Switches are either **Up** (On) or **Down** (Off).

|              | <b>1</b>    | <b>2</b>    | <b>3</b>    | <b>4</b>    | <b>5</b>    | <b>6</b>    | <b>7</b>  | <b>8</b>    |
|--------------|-------------|-------------|-------------|-------------|-------------|-------------|-----------|-------------|
| <b>Set A</b> | <b>Down</b> | <b>Down</b> | <b>Down</b> | <b>Down</b> | <b>Up</b>   | <b>Up</b>   | <b>Up</b> | <b>Up</b>   |
| <b>Set B</b> | <b>Down</b> | <b>Up</b>   | <b>Down</b> | <b>Up</b>   | <b>Down</b> | <b>Down</b> | <b>Up</b> | <b>Up</b>   |
| <b>Set C</b> | <b>Up</b>   | <b>Up</b>   | <b>Down</b> | <b>Down</b> | <b>Down</b> | <b>Down</b> | <b>Up</b> | <b>Down</b> |

# ***Installing Remote Focus Unit***

The Remote Focus Unit (RFU) allows you to set channel levels, check dimmers or run cues from remote locations.

To install the RFU, follow these steps:

1. Verify that RFU power switch is turned **Off**. (Unit is off when switch is in the position toward the bottom edge of the RFU.)
2. Insert the RFU cable into the connector on the back of the console or Remote Interface labeled, **RFU**.
3. Turn RFU power switch to **On**.

## ***RFU console connector***

XLR 6-pin female

## ***RFU pinout***

- 1 Data (+) (to RFU)
- 2 Data (-)
- 3 Data (+) (from RFU)
- 4 Data (-)
- 5 Common (AC ground)
- 6 +12 Vdc (fused, 2 amp)

# Installing MIDI

Connect Insight 2 to any MIDI equipment using a standard MIDI cable.

There are three round, 5-pin, DIN-type connectors labeled **MIDI In**, **MIDI Out**, and **Keyboard** on the back of the console. Turn console power off, then connect the cable from the **MIDI Out** of the electronic instrument or sequencer to the **MIDI In** on the console. Connect the cable from the **MIDI In** on the instrument or sequencer to the connector labeled **MIDI Out**.

*Warning: Do not plug the MIDI cable into the connector labeled **Keyboard**. This connector is for use with an optional alphanumeric keyboard and may damage MIDI equipment.*

If you like, you can set the **MIDI Out** connector as a **MIDI Thru** port. See next page for more information on this option.

Follow these steps to connect MIDI equipment to Insight 2:

1. Turn console power off.
2. Insert standard MIDI cable into the connector on the back of the console labeled **MIDI In**. *Do not insert MIDI cable into connector labeled **Keyboard**.*
3. If you are sending MIDI commands from the console, insert another standard MIDI cable into the connector on the back of the console labeled **MIDI Out**.

## **MIDI console connectors**

DIN 5 pin female

### **MIDI pinout**

- |   |               |
|---|---------------|
| 1 | not connected |
| 2 | Ground        |
| 3 | not connected |
| 4 | MIDI +        |
| 5 | MIDI –        |

## ***MIDI Out/Thru jumper setting***

You may set the **MIDI Out** connector as a **MIDI Thru** port. Follow these steps to do so:

1. Locate the jumper at location J5 (J8 on Insight 2x) on the face panel circuit board in the lid of the console. With the lid in an upright position, the jumper should be near the lower right corner of the circuit board.
2. The jumper at location J5 (J8 on Insight 2x) should be installed on the pair of pins labeled **1 (A)** on Insight consoles) for MIDI Out to be active. To use the **MIDI Out** connector as a **MIDI Thru** connector, move the jumper to the pins labeled **2 (B)** on Insight 2x).

On older consoles (with keyswitch power switches), the jumper locations are slightly different. Follow these steps with older consoles:

1. Locate the jumper at location J7 on the face panel circuit board in the lid of the console. With the lid in an upright position, the jumper should be near the lower right corner of the circuit board.
2. The jumper at location J7 should be installed on the pair of pins labeled **A** for MIDI Out to be active. To use the **MIDI Out** connector as a **MIDI Thru** connector, move the jumper to the pins labeled **B**.
3. Close the console and test for proper operation.

# Installing SMPTE

In order to use SMPTE equipment with Insight 2, the SMPTE option must have been installed at the factory. Connect Insight 2 to SMPTE equipment using an appropriate SMPTE cable.

Follow these steps to connect SMPTE equipment to Insight 2:

1. Turn console power off.
2. Insert SMPTE cable into the connector on the back of the console labeled **SMPTE**.
3. Set DIP switch 4 to enable SMPTE. See *Older console DIP switch settings* on page 277 for instructions.

## **SMPTE console connector**

3 pin female XLR

## **Balanced SMPTE pinout**

- 1 Common
- 2 Signal +
- 3 Signal –

*Note: This pinout is for balanced input. For unbalanced input, make the following connections in the user cable: Connect XLR pin 1 and pin 2 together, tying **Common** to **Signal +**. The unbalanced signal connects to XLR pin 3, **Signal –**.*

## ***ETCNet***

Insight 2 supports ETCNet, a specially designed network that allows you to connect a wide variety of ETC interface devices to the console at remote locations. Through these devices, you can attach monitors, DMX512 devices, RFUs, alphanumeric keyboards, and Designer's Worksheets to the network. Interface devices include the Remote Interface and the Remote Video interface

ETCNet connectors for twisted pair wiring are located on the back panel of the console and all ETCNet interface devices. The connector you use will depend on what kind of wiring your location has installed. For more information about wiring choices, see the *ETCNet Planning and Installation Guide*.

To attach Insight 2 to the ETCNet network, insert the connector at the console end of the network cable into the twisted pair console connector. Attach other devices to the interface device as described in the appropriate sections of this manual.

*Note: For continued compliance with emissions requirements, all cables, with the exception of twisted pair cable, must be shielded.*

## ***ETCNet cabling DIP switch settings***

Before you use the console on the ETCNet network, set the ETCNet DIP switches as described below.

1. Locate the DIP switches on the back panel of the console, to the left of the ETCNet connector(s).
2. Set DIP switch 7 to indicate what kind of wiring you are using.

| <b><i>DIP 7</i></b> | <b><i>Wiring type/connector</i></b> |
|---------------------|-------------------------------------|
| Up                  | BNC (ThinNet) connector             |
| Down                | RJ45 (Twisted Pair) connector       |

3. Set DIP switches 2 and 3 to indicate ETCNet network status.

| <b><i>DIP 2</i></b> | <b><i>DIP 3</i></b> | <b><i>Console mode on start up</i></b> |
|---------------------|---------------------|--|
| Up                  | Up                  | Network off                            |
| Down                | Down                | Network on                             |

4. If you are using Twisted Pair wiring, it may be necessary to change the setting of DIP switch 8. If you are using an external null concentrator, set DIP switch 8 up. If not, set the switch down.

| <b><i>DIP 8</i></b> | <b><i>Twisted Pair Polarity</i></b> |
|---------------------|-------------------------------------|
| Up                  | Off                                 |
| Down                | On                                  |

# Installing Remote Interfaces

Remote Interfaces allow you to attach Expression peripherals to your network. Each Remote Interface contains connectors for three types of network cable (ThinNet, ThickNet and Twisted Pair). Choose the connector that matches your cable type.

To install the Remote Interface, follow these steps:

1. Plug the network connector into the appropriate back panel connector.
2. Plug the power cable into a grounded 120 VAC outlet.

The Remote Interface back panel contains connectors for up to two monitors (the connector labeled CRT 1 is active), three DMX512 outputs and an RFU. The illustration below shows the Remote Interface's back panel and indicates the connector used by each accessory. The front panel includes a connector for a digitizer and an alphanumeric keyboard.

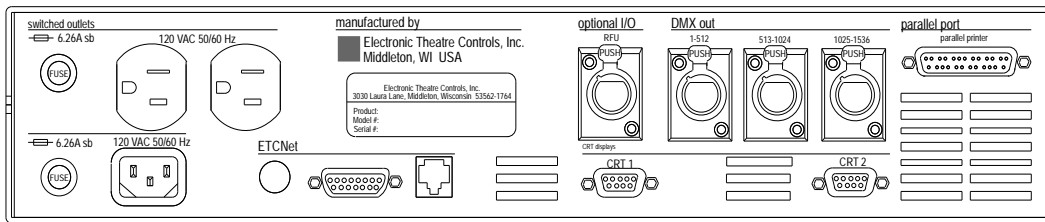

In order to activate the Remote Interface, you must first adjust the settings of a number of DIP switches on the Remote Interface's main circuit board.

## ***DIP switch and jumper settings***

The Remote Interface's main circuit board contains one 8-switch DIP switch unit at location S1 and a set of 14 jumpers at location J22. In order to activate the Remote Interface, you must first adjust the settings on these jumpers and switches.

1. Remove the screws that secure the top panel.
2. Raise the top panel to expose the internal circuitry.
3. Locate jumpers 1 through 14. (location **J22**)
4. If your network cable is plugged into the BNC connector (ThinNet), install jumpers 1 through 6. Be certain jumpers 7 through 12 are not installed.
5. If your network cable is plugged into the RJ45 connector (Twisted Pair) or the DB15 connector (ThickNet), install only jumpers 7 through 12. Be certain jumpers 1 through 6 are not installed.
6. Jumper 13 must always be off. Jumper 14 should always be installed.
7. Locate the DIP switches at location **S1** on the corner of the circuit board nearest the power switch. Switches are either **On (Closed)** or **Off (Open)**. **DIP switch 1 must be Off and 2 must be On or the Remote Interface will not start.** Adjust the settings as necessary to match the table below.

| <b><u>DIP Switch</u></b> | <b><u>Position</u></b> | <b><u>Function</u></b>             |
|--------------------------|------------------------|------------------------------------|
| 1                        | Off (Open)             | Normal operation, Factory Use Only |
| 2                        | On (Closed)            | Normal operation, Factory Use Only |
| 3                        | Off (Open)             | Normal operation, Factory Use Only |
| 4                        | Off (Open)             | Normal operation, Factory Use Only |
| 5                        | Off (Open)             | Normal operation, Factory Use Only |
| 6                        | Off (Open)             | Normal operation, Factory Use Only |
| 7                        | Off (Open)             | Normal operation, Factory Use Only |
| 8                        | Off (Open)             | Normal operation, Factory Use Only |

8. Close the face panel and replace the screws.
9. The Remote Interface checks DIP switch settings when it is turned on. Restart the unit for new DIP switch settings to take effect.

# Installing Remote Video Interface

The Remote Video Interface allows you to attach Expression peripherals to your network. Each Remote Video Interface contains connectors for three types of network cable. Choose the connector that matches your network cable type.

To install the Remote Video Interface, follow these steps:

1. Plug the network cable into the appropriate connector.
2. Plug the power cable into a grounded 120 VAC outlet.
3. If necessary, set DIP switches as described below.

The Remote Video Interface provides ports for remote accessories. It supports one monitor (the connector labeled **CRT 1** is active), an alphanumeric keyboard and an RFU, and provides a serial port for a digitizer. The illustrations below show the Remote Video Interface's front and back panels and indicate the connector used by each accessory.

ETCNet Remote Video Interface back panel

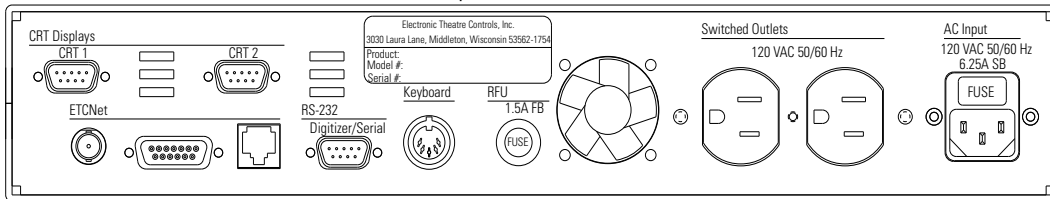

ETCNet Remote Video Interface front panel

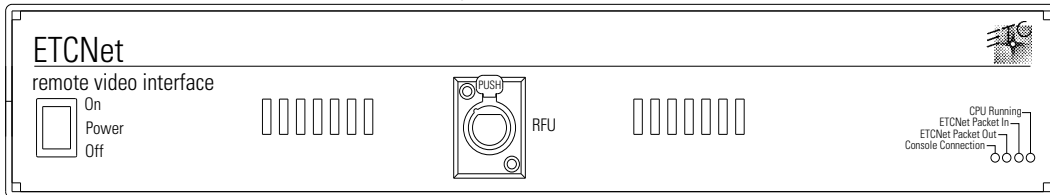

## Remote Video Interface settings

The RVI Processor Board is the lower circuit board in the Remote Video Interface (RVI). It contains one 8-switch DIP switch unit. Under normal conditions, these switches will never need to be changed.

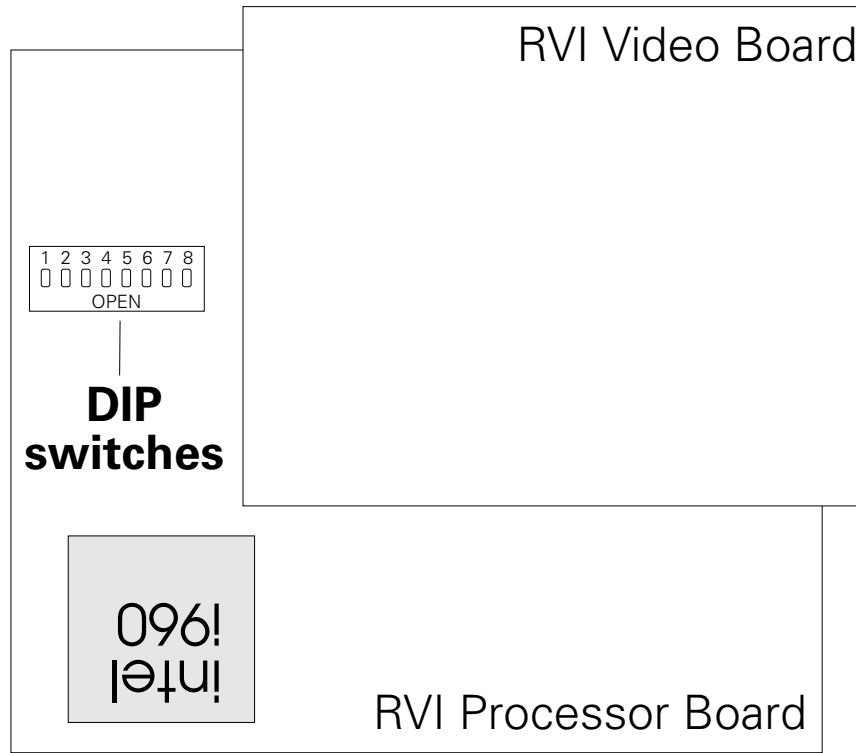

If the settings get changed and you need to restore them, find the switches at location **S4** and adjust the settings as listed below. The Remote Video Interface checks DIP switch settings when unit is turned on. You must restart the unit for the new settings to take effect.

| <u>DIP Switch</u> | <u>Position</u> | <u>Function</u>                    |
|-------------------|-----------------|------------------------------------|
| 1                 | On (Closed)     | Normal operation, Factory Use Only |
| 2                 | Off (Open)      | Normal operation, Factory Use Only |
| 3                 | Off (Open)      | Normal operation, Factory Use Only |
| 4                 | Off (Open)      | Normal operation, Factory Use Only |
| 5                 | Off (Open)      | Normal operation, Factory Use Only |
| 6                 | On (Closed)     | Normal operation, Factory Use Only |
| 7                 | On (Closed)     | Normal operation, Factory Use Only |
| 8                 | Off (Open)      | Normal operation, Factory Use Only |

Switches are either **On (Closed)** or **Off (Open)**.

## **RVI ETCNet DIP switch settings**

In order to enable the Remote Video Interface (RVI) for use on the ETCNet network, you must first adjust the settings of the two sets of ETCNet DIP switches. You will need to use a pin, or a similar fine-pointed object, to set the switches.

To set the switches, follow these steps.

1. Locate the two sets of DIP switches, visible through the right side panel of the RVI.
2. If the ETCNet cable is plugged into the BNC (ThinNet) connector, set the back six DIP switches to **Off** (up). Set the front six to **On** (down).
3. If the ETCNet cable is plugged into the RJ45 (Twisted Pair) connector or the DB15 (ThickNet) connector, set the front six switches to **Off** (up). Set the back six to **On** (down).

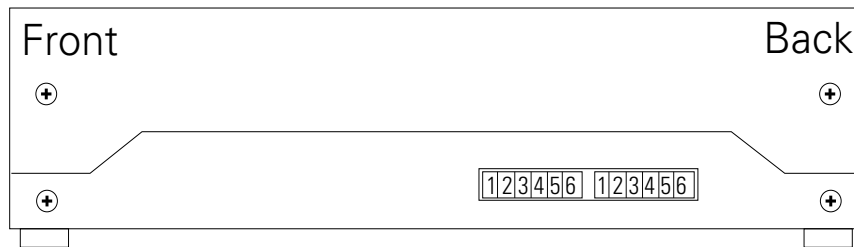

## ***Installing remote unit software***

Follow these steps to upgrade software for any Remote Interfaces or Remote Video Interfaces connected to your Expression control console via the ETCNet network. This will not upgrade software for a Remote Focus Unit (RFU).

1. Installing a new version of Remote Unit software will **not** clear system memory, but it is always best to be prepared. Save your current show!
2. Turn the console off.
3. Insert the Remote Unit Update software diskette into your console's diskette drive.
4. Turn the console back on. The console will display the boot screen and the message **Loading XX%**. Wait until the loading process is complete and the Remote Unit Update Program Menu appears. This menu displays the version number of the software currently being loaded, the console address and a list of all remote devices connected to the network (remote devices must be turned on to appear). It also shows the unit's network address, type and current software version. If your network devices are turned on, but don't appear on the display, and your network uses twisted pair wiring, press [S6], **Swap Twst Pair**. Devices should appear within ten seconds.

### ***Updating software to all remote devices***

To update the software on all remote devices, press [S1], **Update All Units**.

### ***Updating software on selected remote devices***

To update the software on multiple, remote devices, use the arrow keys to move through the list of devices. When the device you want to update is highlighted, press [S8], **Mark This Unit** to select that device. An **M** appears to the left of the device name, indicating that this device has been selected for updating. Repeat this procedure for each device you want to update, then press [S2], **Update Marked** to update the software in each of the marked devices.

### ***Updating software on a single remote device***

To update the software on a single remote device, use the arrow keys to select the device, then press [S3], **Update This Unit**.

Under the Status column in the Remote Units list, the percentage of completion will be shown. When the word **Pass** is visible, the update process is done.

5. Remove the Remote Unit Update disk from the console diskette drive.
6. Turn the console off and then back on again. The process is complete.

If you have any questions or experience difficulties while upgrading, please call ETC's Technical Services department at 800/775-4382.

## ***Installing remote video monitors***

You may want to install additional monitors at remote locations. Install monitors by connecting them to any interface devices on ETCNet. Additional monitors duplicate the master console's displays in remote locations.

Connect monitors to interface devices by following these steps.

1. Insert the female end of the monitor power cord in the monitor connector, and the male end of the monitor power cord in the interface device connector labeled **Switched outlets**.
2. Connect the cable to the connector labeled **CRT 1** on the interface device.
3. Turn monitor power switch to its **On** position.

### ***VGA monitor console connector***

HD-DB15 female

### ***VGA monitor pinout***

|    |               |
|----|---------------|
| 1  | Red video     |
| 2  | Green video   |
| 3  | Blue video    |
| 4  | Ground        |
| 5  | Ground        |
| 6  | Red ground    |
| 7  | Green ground  |
| 8  | Blue ground   |
| 9  | not connected |
| 10 | Ground        |
| 11 | Ground        |
| 12 | not connected |
| 13 | H. (H/V) sync |
| 14 | V. sync       |
| 15 | not connected |

# ***Installing Infrared Remote Focus Unit***

The optional Infrared Remote Focus Unit (IRFU) allows you to set channel levels, check dimmers or run cues from remote locations in your studio or theatre. The IRFU consists of two components; a receiver and a transmitter. The receiver is connected to the console with a standard multi-conductor cable. The transmitter is a hand-held, wireless unit that sends infrared control signals to the receiving unit.

To install the infrared remote control unit, follow these steps:

1. Verify that the receiver unit is properly connected to the console and that battery in transmitter is good. (See infrared remote documentation for correct connection procedure.)
2. Press [Setup].
3. Select 6, **Options Settings**, and press [Enter].
4. Select 4, **Infrared Remote**, and press [Enter].
5. Enter **1** to enable the IRFU or **0** to disable the IRFU. Press [Enter].
6. Press [On] key on the transmitter unit to turn power on. (Transmitter power automatically shuts off if no keys are pressed for three minutes.)

## ***IRFU console connector***

DIN 5-pin female

## ***IRFU pinout***

- 1 Ground
- 2 PPM data
- 3 +12V
- 4 WSI data
- 5 Charge current

## Installing remote macros

The console provides eight remote macro inputs through the 25-pin connector on the back panel labeled **Remote Go**. A user-supplied remote device connects to the console via a 24 AWG, aluminum-shielded, multi-conductor cable with one twisted pair designated for each switch (Belden 9507 S-R PCV Insulated or Alpha 5477 80 Deg. C 300 V PVC). The cable connector at the remote device will vary depending on the device itself.

### **Console connector**

DB-25 female

### **Remote connector**

Connector type depends on unit

| <b>Pin</b> | <b>Function</b> |
|------------|-----------------|
| 1          | - Macro 1,901   |
| 2          | - Macro 1,902   |
| 3          | - Macro 1,903   |
| 4          | - Macro 1,904   |
| 5          | - Macro 1,905   |
| 6          | - Macro 1,906   |
| 7          | - Macro 1,907   |
| 8          | - Macro 1,908   |
| 9          | not connected   |
| 10         | Ground          |
| 11         | + 12 Vdc        |
| 12         | not connected   |
| 13         | not connected   |
| 14         | + Macro 1,901   |
| 15         | + Macro 1,902   |
| 16         | + Macro 1,903   |
| 17         | + Macro 1,904   |
| 18         | + Macro 1,905   |
| 19         | + Macro 1,906   |
| 20         | + Macro 1,907   |
| 21         | + Macro 1,908   |
| 22         | not connected   |
| 23         | Ground          |
| 24         | + 12 Vdc        |
| 25         | not connected   |

## Wiring remote macros

There are three typical ways to wire the Remote Go function:

- Connect all -Macro pins (pins 1-8) to ground (pin 10) and switch the leads connecting the +Macro pins (pins 14-21) to +12 Vdc (pin 24) as shown in the following diagram.

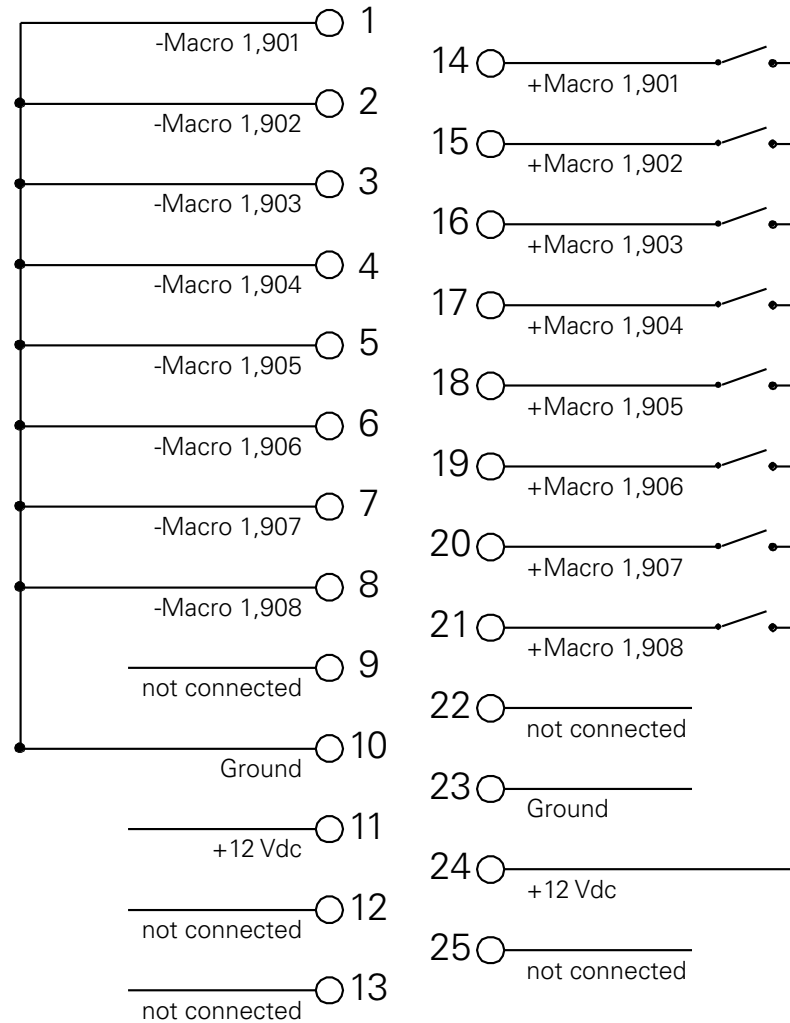

- Connect all +Macro pins (pins 14-21) to the +12 Vdc pin (pin 24) and switch the leads connecting the -Macro pins (pins 1-8) to the ground (pin 10).
- Provide your own power supply that generates a 12 Vdc potential between the +Macro and -Macro pins and switch either of these leads.



# appendix b

## error messages

### **Diskette error messages**

#### **Bad Disk**

Disk is unformatted or defective. Try formatting it. If that doesn't work, try a different disk.

#### **Write-protected disk**

The write-protect tab on this diskette is open. Close the tab to unprotect the diskette.

#### **No disk in drive**

Show diskette must be inserted in the diskette drive before you can save or read a show.

#### **Disk controller failure**

Call ETC Technical Service at 800/775-4382.

#### **Unknown disk error - try again**

Try the diskette again. If it fails again, call ETC Technical Service at 800/775-4382.

#### **Corrupted Disk**

This disk is defective. Try formatting it. If that doesn't work, try a different disk.

#### **File not found**

This disk does not appear to have a show stored on it. Please confirm that you have inserted the correct disk.

#### **Disk full**

Disk contains other files. Remove enough files to make room for show file.

#### **Disk access failed because of tracking failure**

This message appears on the backup console in a Full Tracking Backup system when the network or the master console fails during a diskette operation.

## **Other error messages**

### ***Out of memory***

You have used up all system memory allotted to the function with which you are working. Delete unnecessary parts of the show to free up memory. If this doesn't work, you may want to break the show into two shows, one for each act. This message may also appear if you attempt to run too many effects.

***System Error - This software version is incompatible with the existing hardware. Please reload the correct version of software, or contact your service representative for further assistance.***

***The Designer's Worksheet setup and regions stored in show memory DO NOT match what is being loaded from disk. To preserve current Worksheet setup, press ENTER. To load new Worksheet setup and regions from disk, press CLEAR.***

Press [Enter] to retain the layout option you previously selected on the Designer's Worksheet setup screen. Existing regions have already been erased.

Press [Clear] to replace the current Designer's Worksheet layout option with the new show's layout. New regions will be loaded with the new show.

## **ETCLink errors**

ETCLink provides advisory messages for a wide variety of conditions, including information regarding your dimmers, racks, system, data, ports, and loads. These messages fall into two categories, fatal messages and secondary messages.

Fatal messages deal with anything that could potentially terminate or drastically change the look of your show. You may set fatal messages to be displayed even when secondary messages have been disabled.

Secondary messages deal with individual dimmer problems and warnings of potential rack temperature problems. These messages are generally less critical than the fatal messages. If you wish, secondary messages may be disabled without disabling fatal messages. See *Disabling secondary messages* on page 228 for more information.

### **Fatal messages**

**Dimmer # has shut down due to an overtemperature condition. The dimmer will remain shut down until the condition is cleared at the dimmer rack. Use Dimmer Status to determine the rack number for the dimmer.**

**Rack # DMX port A/B failure. Either there is a problem with the DMX cabling/connections between the console and the rack, or the rack has been configured incorrectly.**

**Rack # A/B/C phase input (main) voltage is in error at #V.**

**Rack # input (main) frequency is out of spec at #Hz.**

**Rack # has shut down due to fan failure or other interruption of air flow. Please check the rack, looking for dirty air filters, blocked air passages, or fan failure.**

**ETCLink has failed. Please check cabling and connections. If the problem persists, please call a qualified service technician.**

**Rack # processor error.**

## ***Secondary Messages***

**Dimmer # has a load, but the recorded load is zero. Because the recorded load is zero, the Dimmer Monitoring system is unable to determine whether the dimmer has a load error.**

**The load on dimmer # has changed. Because the dimmer output is not at a high enough level, the Dimmer Monitoring system is unable to determine the size of the load. To correct the problem use [Check Loads] to determine the size of the load change.**

**The load on dimmer # has changed from #W to #W. A decreased load indicates lamp failure. An increased load indicates that a lamp has been added since the last [Record Load]. Correct the problem or, to prevent further error messages, use [Clear Load] or [Record Load].**

**DC output has been detected on dimmer #. If this condition persists, it may harm the connected load. Please check the connected load.**

**An SCR has failed On/Off in dimmer #. The dimmer should be replaced.**

**Dimmer # output has failed on. The dimmer should be replaced.**

**Dimmer # output has failed off. Either the circuit breaker has tripped or the dimmer needs to be replaced.**

**Dimmer #'s load has failed. The most likely cause is a lamp failure. Either replace the lamp or, to prevent further error messages, use [Clear Load] or [Record Load].**

**Data error on Rack # DMX port A/B. Please check DMX cabling and connections between the console and the rack.**

**Rack # ambient temperature is high at # degrees F. The temperature does not yet exceed acceptable operational limits, but the rack should be checked. Please check the cooling/ventilation in the dimmer room.**

**Rack # ambient temperature is low at # degrees F. Please check the cooling/ventilation in the dimmer room.**

**Rack # ambient temperature is outside the acceptable operating range at # degrees F. Please check the cooling/ventilation in the dimmer room immediately.**

**The phasing in Rack # is not allowed. The rack has been shut down. Please check the input power service.**

# *appendix c*

## *specifications*

### ***Electrical***

- Voltage input 90-250 VAC, 50-60 Hz
- Maximum current 6.3 amps

### ***Internal interfaces***

- Up to 1,024 DMX512 outputs
- Parallel printer
- RS-232C serial port
- Remote Focus Unit
- Infrared Remote Focus Unit
- Remote Macro option
- Alphanumeric keyboard
- MIDI
- SMPTE
- DMX512 Input
- ETCLink

### ***System capacity***

- 600 cues per show
- 108 control channels
- Proportional patching of up to 1,024 DMX512 dimmers
- Eight-part multipart cues
- Ten dimmer profile options
- 500 groups
- 2,000 macros/regions
- 3,000 SMPTE events
- 108 overlapping submasters
- Ten pages of submaster memory
- Two timed/manual fader pairs

### ***Fader functions***

- Fade times programmable from .1 second to 99:59 minutes
- Manual override of upfade and/or downfade
- Rate override
- Split time fades
- Manual fades
- User selectable default fade times
- Hold/Back functions

## ***Playback controls***

- Two timed/manual fader pairs
  - Two [Go] buttons
  - Two [Hold] buttons
  - Two [Back] buttons
  - Two [Rate] buttons
  - Two [Clear] buttons
- 108 submasters
- Programmable Master on 100mm potentiometer
- Blackout function
- Level/Rate wheel
- Eight softkeys to streamline operations

## ***Display functions***

- One VGA video output
- Extensive online Help displays available for all functions
- Stage
- Blind
- Fader
  - A/B fader
  - C/D fader
  - Both faders
  - DMX In
- Tracksheet
- Patch
- Park
- Setup
- Flexichannel (displays only recorded channels)

## ***Submaster functions***

- Ten pages of 108 recorded submasters
- Fully overlapping channel assignments
- Proportional channel levels
- Bump buttons on all 108 submasters may be placed in enabled, disabled or solo mode as a group or individually
- Integral LEDs on all 108 submasters
- Programmable fade and wait times
- Live and programmed rate control
- 36 submasters programmable for overlapping pile-on or inhibitive operation
- All submasters programmable with effects
- Update function
- Control keypad features
- Submaster 108 may be used to master DMX In levels
- Submaster labels

## ***Channel functions***

- Group function to allow channels to be manipulated as proportionally balanced groups
- Proportional adjustment with level wheel
- [And], [Except], [Only], and [Thru] functions for selection of control lists
- [Full] function
- [Level] sets a channel to a user-selectable default value
- Channel Attribute display provides Independent, Flip channel and channel Label attributes

## ***Cue functions***

- Up to 600 cues numbered .1 to 999.9
- Discrete upfade and downfade times (00:00-99:59) for each cue
- Linked cue sequences
- Effect cues
- Split wait times
- Follow time
- Link to cue or macro
- Label
- Eight-part multipart cues
- Selective cue recording
- Update cue command
- Attribute range editing
- Subroutines

## ***Group functions***

- Up to 500 groups
- Any cue or submaster may be accessed as a group
- Group labels

## ***Diskette drive***

- 3.5-inch high-density diskette drive for show storage
- One show per disk
- Software updates installed through diskette drive

## ***Macro functions***

- Up to 2,000 macro selections for programming
- Macros may activate any key on the console
- Live Learn mode
- Blind editing
- Macros programmable for **Macro wait**
- Real Time Clock event programming
- Powerup macro
- \* Remote Trigger function

## ***Effects functions***

- Up to 100 steps each
- Variability of rate during playback
- Step times
- In/Dwell/Out Step fade times
- High/Low Levels
- In/Dwell/Out Effect fade time
- Effects may be recorded as cues or submasters
- Range editing of effect attributes and step values

## ***Profile functions***

- Ten preset profiles
- Profiles may be assigned to dimmers

## ***Level wheel***

- Proportional intensity control of channels or groups
- Proportional rate control of cues and submasters from zero to 2,000 percent

## ***Options***

- Parallel printer
- Alphanumeric keyboard
- Remote Focus Unit
- Infrared Remote Focus Unit
- Designer's Worksheet
- Lighting Playback Controller
- Remote VGA monitors
- Remote Interface
- Remote Macros
- Dimmer feedback

## ***Size and weight***

- 44 x 16.5 x 6.5 inches
- 50 pounds

# *appendix d*

## *reference*

This appendix lists most Insight 2 functions, keys and softkeys in alphabetical order. Listings include a description and instructions or examples, as appropriate, for using it.

## **A**

**A is softkey [S2] in the Patch, Park and ETCLink Functions displays**  
[S2], **A**, allows selection of the A output of a multiplex dimmer.

Example: [Patch] [Dimmer] [1] [S2], **A**, [Channel] [6] [Enter] patches the A half of multiplex dimmer 1's output to channel 6.

## **Allfade**

An allfade cue forces all unused channels to zero intensity when you press [Go] and clears the other fader. Allfade is useful for forcing an end cue when tracking channels.

## **Alphanumeric keys**

Use the optional alphanumeric keyboard to label cues, groups or submasters and to name shows.

## **Alternate**

**Alternate is softkey [S2] in the Attribute list of the Effect display**

Use [S2], **Alternate**, to program an effect that changes between positive and negative on each pass through the steps. If the effect is positive, the first pass will be positive, the second negative, the third positive, etc. If the effect is negative, the first pass will be negative, the second positive, etc. To cancel the Alternate attribute, press [S2] again.

## **And**

Use [And] to select more than one dimmer, group or channel in a single statement.

Example: [Channel] [1] [And] [5] [And] [8] [At] [7][5] sets channels 1, 5 and 8 at 75 percent.

## **At**

Use [At] to enter the intensity for a selected dimmer, channel or group.

Example: [Channel] [1] [And] [4] [At] [4][5] sets channels 1 and 4 at 45 percent.

## **Attribute**

**Attribute is softkey [S8] after [S7], More Softkeys, in the Effect display**

Use [S8], **Attribute**, to access the effect attribute selection softkeys.

## **B**

**B is softkey [S3] in the Patch, Park and ETCLink Functions displays** [S6], **B**, allows selection of the B output of a multiplex dimmer.

Example: [Patch] [Dimmer] [1] [S6], **B**, [At] [7][5] gives the B half of multiplex dimmer 1 a patch level of 75 percent.

## **Back**

Use [Back] to replace the cue in the fader with the previous cue.

## **Blackout**

Press [Blackout] to reduce all channel outputs on stage to zero. Press [Blackout] again to restore lights. Independent channels are not affected by [Blackout]

## **Blind**

The Blind display allows you to create and modify cues, groups and submasters without affecting current live levels. Blind also allows you to create effects and subroutines.

## **Bounce (effect)**

**Bounce is softkey [S4] in the attribute list of the Effect display**

Use [S4], **Bounce**, to create an effect that alternates between a forward chase and a reverse chase. If the effect is not assigned the reverse attribute, the first pass will be forward, the second reverse, the third forward, etc. If the effect is assigned the reverse attribute, the first pass will be reverse, the second forward, etc. To cancel the Bounce attribute, press [S4] again.

## **Bounce (subroutine)**

The subroutine runs through steps until it reaches a Bounce step. It then runs back through the steps in reverse order, and repeats the sequence for the number of times you specify.

When you create the Bounce step, enter the number of times you want the subroutine to bounce. One bounce equals running through the sequence forward once and reverse once. Enter **0** for a continuous bounce.

## **Build**

**Build is softkey [S5] in the attribute list of the Effect display**

Use [S5], **Build**, to cause each step in an effect to remain active until the entire step list is executed. When the step list begins again, all steps go out and the cycle begins again. To cancel the Build attribute, press [S5] again.

## ***Bump (SMPTE)***

***Bump is softkey [S5] after [S7], More Softkeys, in the SMPTE Events display***

Use [S5], **Bump**, to access the submaster bump field in the SMPTE Events display.

## ***Bump Status***

***Bump Status is softkey [S1] in the Blind Submaster displays***

Use [S1], **Bump Status**, to change the function of the submaster bump button. Choices are: enabled, disabled or solo

Example: [S1], **Bump Status**, [2] [Enter] disables the bump button of the selected submaster

## ***Calibrate***

[Calibrate] is a region on the Designer's Worksheet. Whenever you install a new template on the digitizer tablet, use [Calibrate] to line up the keys and regions correctly. Using the digitizer pen, touch the region labeled **Calibrate** or touch [F1]. Then follow the directions on the screen that instruct you to touch the pen to the regions labeled **A**, **B** and **C**.

## ***Cancel***

***Cancel is softkey [S7] in the Load Management display***

Use [S7], **Cancel**, to interrupt a Record Loads operation that has already started.

## ***Captured channels***

Captured channels are channels that you have selected and are live on stage. They remain live until you press [Rel] to release them. **Captured channels override all other channel settings.** For example, if a channel is in a fader at 100 percent and you capture it and set it to 50 percent, Insight 2 sets the captured channel at 50 percent. Press [Rel] twice to release captured channels.

## ***Channel***

Use [Channel] to select a channel or group of channels. Use of this key is often optional.

Example: [Channel] [1] [Thru] [9] [Except] [4] [At] [7][5] sets channels 1 through 3 and 5 through 9 to 75 percent.

## ***Clear (keypad)***

Use [Clear] to clear the current keypad entry. Press twice to clear all entries.

Example: [Channel] [5] [Clear] [8] [Enter] selects channel 8.

## **Clear (fader)**

Use the fader [Clear] to clear a fader pair of any cues which have been assigned to it. Also use [Clear] to initiate the downfade of an effect cue.

## **Clear Loads**

**Clear Loads is softkey [S6] in the Load Management display**

Use [S6], **Clear Loads**, to disable dimmer monitoring for selected dimmer loads.

## **Clear Region**

**Clear Region is softkey [S6] in the Designer's Worksheet Editing display**

Use [S6], **Clear Region**, to erase a recorded region.

Example: [S6], **Clear Region**, [3] [Enter] [Enter] removes region 3 from the Designer's Worksheet layout. It does not affect macro 3.

## **Clock Enable/Disable**

**Clock Enable/Disable is softkey [S2] in the SMPTE Events display**

Use [S2], **Clock Enable/Disable**, to start or stop the SMPTE internal clock. If SMPTE input is enabled, the internal clock will hold until the first SMPTE frame is received, or until started manually by pressing [S1], **Internal Clock**. If the clock is disabled, the SMPTE events will only be executed if SMPTE input is received.

## **Copy Event**

**Copy Event is softkey [S2] after [S7], More Softkeys, twice, in the SMPTE Events display**

Use [S2], **Copy Event**, to copy a group of SMPTE events. The target time of the first event in the group must be specified. The original spacing of subsequent events will be maintained.

## **Copy Macro**

**Copy Macro is softkey [S5] after [S7], More Softkeys, in the Macro Editing display**

Press [S5], **Copy Macro**, to copy the contents of one macro to a second macro. If the destination macro is already recorded, the console will require a confirmation.

Example: [S1], **Select Macro**, [5] [S7], **More Softkeys**, [S5], **Copy Macro**, [9] [Enter] copies macro 5 to macro 9.

## Copy Program

**Copy Program is softkey [S2] after [S7], More Softkeys, in the Real Time Programs display**

Use [S2], **Copy Program**, to copy a group of programs. The target time of the first program in the group must be specified. The original spacing of subsequent programs is maintained.

## Copy Region

**Copy Region is softkey [S5] after [S7], More Softkeys, in the Designer's Worksheet Editing display**

Press [S5], **Copy Region**, to copy the contents of one region to a second region. If the destination region is already recorded, the console will require a confirmation.

Example: [S1], **Select Region**, [5] [S7], **More Softkeys**, [S5], **Copy Region**, [9] [Enter] [Enter] copies region 5 to region 9.

## Crossfade

In a crossfade cue, channel levels that increase fade to their new level in the assigned upfade time. Channel levels that decrease fade to their new level in the assigned downfade time. The cue starts when you press [Go]. You may use a wait time to delay the start of the upfade or downfade.

## Cue

Use [Cue] to select a cue number.

Example: [Cue] [156.1] selects cue 156.1.

## Cue (SMPTE)

**Cue is softkey [S3] after [S7], More Softkeys, in the SMPTE Events display**

Use [S3], **Cue**, to access the cue fields in the SMPTE Events display. Press once to select the A/B field, twice to select the C/D field.

## Cue List

The Cue List appears on the display. The Cue List provides a list of cues for the show, including all of the cues' programmed attributes. In addition, the playback display provides information about which cue is active or running and on which fader the cue is running.

The Cue List will display the playing cue or the last cue played and then the pending cue. **The pending cue is highlighted in yellow.**

## **Cue List**

**Cue List is softkey [S2] in the Blind Cue and Blind Subroutine displays**

Use [S2], **Cue List**, to access the Cue List display, which provides a list of recorded cues and cue attributes.

## **Cue steps (subroutine)**

There are two types of cue step, crossfade and allfade. The type determines how the step's fade runs.

### **Crossfade**

All increasing levels fade during the upfade time; all decreasing levels fade during the downfade time.

### **Allfade**

All channels in both faders fade to the level set in the allfade step.

## **Days of week**

**Days of week is softkey [S3] in the Real Time Programs display**

Use [S3], **Days of week**, to select on which days of the week the real time program will run.

## **Decimal point**

Use the decimal point [.] to select decimal cue numbers (.1-9) or decimal fade times.

Example: [Cue] [5] [.] [1] [Time] [.] [5] [Enter] sets the fade time for cue 5.1 to half a second

## **Delete**

**Delete is softkey [S6] after [S7], More Softkeys, in the Stage and Fader displays**

Use [S6], **Delete**, to delete the contents of a cue or group. The keypad assumes a cue unless otherwise instructed.

Example: [S6], **Delete**, [6] [Enter] [Enter] deletes cue 6.

Example: [S6], **Delete**, [Group] [5] [Enter] [Enter] deletes group 5.

## **Delete Cue**

**Delete Cue is softkey [S6] in the Blind Cue and Blind Subroutine displays**

Press [S6], **Delete Cue**, to delete the contents of a selected or specified cue.

Example: [S6], **Delete Cue**, [6] [Enter] [Enter] deletes cue 6.

Example: [S6], **Delete Cue**, [Enter] [Enter] deletes the selected cue.

## **Delete Entry**

**Delete Entry is softkey [S3] in the Macro Editing and Designer's Worksheet display**

Use [S3], **Delete Entry**, to clear a button entry from a macro. Use the left and right arrow keys to move to the required entry. When selected, it will be highlighted in yellow. Press [S3] to clear the entry.

## **Delete Event**

**Delete Event is softkey [S6] after [S7], More Softkeys, in the SMPTE Events display**

Use [S6], **Delete Event**, to delete SMPTE events from the event list.

## **Delete Group**

**Delete Group is softkey [S6] in the Blind Group displays**

Press [S6], **Delete Group** to delete the contents of a selected or specified group.

Example: [Delete Group] [6] [Enter] [Enter] deletes group 6. Example: [Delete Group] [Enter] [Enter] deletes the selected group.

## **Delete Macro**

**Delete Macro is softkey [S6] in the Macro Editing display**

Use [S6], **Delete Macro**, to remove all recorded information from a macro.

Example: [S6], **Delete Macro**, [3] [Enter] [Enter] erases the contents of macro 3.

## **Delete Part**

**Delete Part is softkey [S6] in the Blind Multipart display**

Press [S6], **Delete Part**, to delete one part of a selected or specified multipart cue.

Example: [S6], **Delete Part**, [6] [Enter] [Enter] deletes part 6.

Example: [S6], **Delete Part**, [Enter] [Enter] deletes the selected part.

## **Delete Program**

**Delete Program is softkey [S6] in the Real Time Programs display**

Use [S6], **Delete Program**, to remove a program from the program list. All subsequent programs are renumbered..

## Delete Step

**Delete Step is softkey [S6] after [S7], More Softkeys, in the Blind Effect and Blind Subroutine displays**

Press [S6], **Delete Step**, to delete the selected step or a specified step.

Example: [S6], **Delete Step**, [4] [Enter] [Enter] deletes step 4. Example: [S6], **Delete Step**, [Enter] [Enter] deletes the selected step.

## Delete Sub

**Delete Sub is softkey [S6] in the Blind Submaster and Sub List displays**

Use [S6], **Delete Sub**, to clear a submaster of its recorded or loaded contents.

Example: [S6], **Delete Sub**, [Enter] [Enter] unloads the selected submaster.

Example: [Sub List] [S6], **Delete Sub**, [1] [Thru] [8] [Enter] [Enter] unloads subs 1 - 8

## Dimmer

Use [Dim] to start a dimmer check, park a dimmer, or to change dimmer patch assignments.

Example: [Dim] [1] [At] [Full] [Enter] [+] [+] [+] ...

Example: [Park] [Dim] [1] [At] [7][5]

Example: [Patch] [Dim] [6] [Channel] [7] [Enter]

## Dimmer Status

**Dimmer Status is softkey [S5] in the System Status and Rack Status displays**

Use [S5], **Dimmer Status**, to Check information about your dimmers, including size and type, recorded load, firing mode, output curve, rack, slot, panic mode, and boost.

## Disable ETCLink

**Disable ETCLink is softkey [S1] in the ETCLink Functions display**

Use [S1], **Disable ETCLink**, to turn off dimmer monitoring. Softkey then becomes **Enable ETCLink**.

## Disable MIDI

**Disable MIDI is softkey [S1] in the Options Settings display**

Use [S1], **Disable MIDI**, to disable either ETC MIDI or MIDI Show Control. Both MIDI protocols may be enabled at the same time, and are disabled individually.

## **DMX512 Mode**

**DMX512 Mode is softkey [S2] in the Input/Output Configuration display**

Use [S2], **DMX512 Mode**, to set a DMX512 port to multiplex mode or normal mode. Multiplex mode allows dimmers to be used with ETC Source 4 multiplexers. Switching from multiplex to normal mode will cause dimmers on that port to be taken out of the patch.

## **DMX512 Port**

**DMX512 Port is softkey [S1] in the Input/Output Configuration display**

[S1], **DMX512 Port**, allows selection of a DMX512 output port to put into multiplex mode or to change the starting DMX512 number. DMX512 starting numbers may not be changed by the user if any port is in multiplex mode.

Example: [S1], **DMX512 Port**, [3] [S2], **DMX512 Mode**, [Enter] [1] [Enter] sets port 3 to multiplex mode.

## **DMX512 Speed**

**DMX512 Speed is softkey [S4] in the Input/Output Configuration display**

[S4], **DMX512 Speed**, changes the DMX512 transmission rate to accommodate DMX512 receivers that accept data at different rates. Four rates are available: Max, Fast, Medium, and Slow. The DMX Speed should be set to Max when used with ETC DMX512 receivers. Other equipment may require slower speeds.

## **DMX512 Start**

**DMX512 Start is softkey [S3] in the Input/Output Configuration display**

Use [S3], **DMX512 Start**, to set the starting dimmer number of a DMX512 port. If any port is in multiplex mode, the starting numbers may not be changed.

## **DMX In**

**DMX In is softkey [S8] after [S7], More Softkeys, in the Stage and Fader displays**

Use [S8], **DMX In**, in Stage mode to record only the DMX512 input levels into a cue, group or submaster and in Fader mode to view any DMX512 input to the console.

Example: [Record] [Cue] [8] [S8], **DMX In**, [Enter] records only the current DMX512 input levels into cue 8.

Example: [Record] [Cue] [5] [Except] [S8], **DMX In**, [Enter] records current live levels on stage, except for those set by DMX512 input, into cue 5.

## **Down Arrow**

Use [↓] to move through various displays, such as the Effect and Macro Editing display modes or the Stage and Blind displays.

## **Effect**

Insight 2 allows you to create up to 600 effects, each with up to 100 steps. Effects allow you to assign channels to a series of steps. When you play back the effect, the steps run in assigned chase patterns, or in random order. You may record them as cues or submasters. Each effect includes level and timing controls for the steps in the effect, and overall timing controls for the effect itself. Each effect can run for up to 99:59 minutes.

*Note: Current channel levels are not affected by an effect until a step runs that specifically addresses the channel.*

## **Effect cue**

An effect cue contains an effect. Effects allow you to assign channels to a series of steps. When you play back the effect, the steps run in assigned chase patterns, or in random order.

## **Effect submaster**

An effect submaster contains an effect. Effects allow you to assign channels to a series of steps. When you play back the effect, the steps run in assigned chase patterns, or in random order. Play the effect by pressing the submaster bump button or by raising the submaster slider.

## **Enable ETCLink**

### **Enable ETCLink is softkey [S1] in the ETCLink Functions display**

Use [S1], **Enable ETCLink**, to allow dimmer monitoring on a system connected by ETCLink to a Sensor dimming system. Softkey then reads **Disable ETCLink**.

## **Enter**

Use [Enter] to advance the operator prompt or terminate/verify selected console functions.

Example: [Record] [6] [Enter] records cue 6.

Example: [Load Sub] [5] [Group] [6] [Enter]

## **Enter Macro**

Use [Enter Macro] to terminate the recording of a macro instruction. This is the last step in recording a macro, whether in Learn mode or blind Macro Edit, unless an instruction to run another macro is used to terminate recording.

Example: [Learn] [9] [Enter] [Record] [Cue] [5] [Except] [Sub] [1] [Enter Macro] records macro 9.

## Except

Use [Except] to exclude channels, dimmers or groups from selection or record operations.

Example: [Record] [Cue] [5] [Except] [Sub] [3] [Enter] records the current look in cue 5, except for the channels included in submaster 3.

Example: [Channel] [1] [Thru] [9] [Except] [5] [At] [5] sets channels 1 through 4 and 6 through 9 at 50 percent.

## Fader

The Fader display allows review and modification of channels in the A/B and C/D faders without affecting other channel levels.

## Fader status display

The fader status display consists of two windows at the bottom of the playback monitor. It provides information about the cues loaded to Insight 2's faders, including fade times and rates. The left window monitors the A/B fader, the right window monitors the C/D fader. The display counts down wait times for cues and indicates which step is running when an effect is active.

The illustration below shows the fader status display:



## Flash

### **Flash is softkey [S8] in the Stage display**

[S8], **Flash**, sets the selected channel's level to 100 percent if the channel is currently at a level at or below 50 percent. If the channel's level is above 50 percent, **Flash** sets it to zero. Levels set by Flash are only maintained while the key is pressed. For example, press [Channel] [5], then press and hold [S8], **Flash**, to set channel 5 to either 100 or zero. Use [+] and [-] to advance the channel while [Flash] is pressed.

Example: [4] [S8], **Flash**, flashes channel 4.

## **Flexichannel**

Insight 2's Command display can be set to operate in full display mode or in Flexichannel mode. In full display mode, channel displays show all channels and their current status. In Flexichannel mode, independent, flipped and linked channels and channels with a recorded level appear. Insight 2 defaults to full channel display. Flexichannel may be enabled or disabled from the System Settings menu.

## **Flip**

### **Flip is softkey [S2] in the Channel Attributes display**

Use [S2], **Flip**, to mark a channel 'flipped'. The flipped channels will have their outputs inverted. The levels will not appear inverted on the Stage display. See *Flipped channels* for more information.

## **Flipped channels**

The Flip command in the Channel Attributes display inverts the output of the channel to which it is applied. A flipped channel outputs at full when set to zero and at zero when set to full.

Use [S2], **Flip**, to mark a channel flipped. The flipped channels will have their outputs inverted. The levels will not appear inverted on the Stage display. Channel control can be flipped; this inverts the level sent to the channel.

Use Flip to control moving lights. Link the channels that control the pan attribute for moving lights on opposite sides of the stage and Flip one of the two channels. When you control the two lights, their movements are mirrored, rather than parallel.

## **Follow**

[Follow] allows you to play a series of cues automatically. The [Follow] time indicates how long the console waits after the cue starts before the next cue runs. [Follow] plays back the next cue on the Cue List unless you use [Link] to specify a different sequence. To remove a follow time from a cue, press [Follow] [Clear].

Example: [Cue] [1] [Follow] [1] [Enter] assigns a follow time of one second to cue 1. Cue 2 will start one second after cue 1 starts

## **Full**

Use [Full] to assign a level of 100% to a dimmer channel or group.

Example: [Channel] [1] [Thru] [1][0] [Full] sets channels 1 through 10 to 100 percent.

## **Go**

Press [Go] to execute the next cue in the key's associated fader.

Example: [Cue] [1] [A/B Go] runs cue 1 in the A/B fader.

## **Groups**

Insight 2 allows you to record frequently used combinations of channels into units called groups. You may record up to 500 groups.

Once you record a group, it can be combined with other channels to create cues, submasters, effects, or other groups. The principal difference between a group and a cue is that a group cannot be played back through a fader or slider. Consequently, it has no fade times, wait times or other playback attributes.

Group numbers are independent of cue numbers and may be numbered from 1 to 999.

## **Group**

Use [Group] to select, record or recall a proportional group of channels. Cues and submasters may also be recalled as groups.

Example: [Record] [Group] [1] [Enter] records the current look as group 1.  
Example: [Group] [Cue] [3] [at] [5][0] brings up the channels in cue 3 as a group and sets them to 50 percent of their recorded levels.

## **Group Editing mode**

In Group Editing mode, Insight 2 brings up the selected group itself and allows you to modify it. In this mode, use [S1], **Select Group**, rather than [Group], to bring up a different group. Use [Group] to access a group's levels as you modify the selected group.

## **Group mode**

In Group mode, Insight 2 brings up the channels from a group of your choice and allows you to use them to modify cues and submasters.

## **Group List**

### **Group List is softkey [S2] in the Blind Group display**

Use [S2], **Group List**, to access the Group List display which provides a list of recorded groups and their labels

## **Help**

Press [Help], followed by any key to receive a brief description of the key's function.

## **Hold**

### **Hold is softkey [S2] in the Sub List display**

Press [S2], **Hold**, when entering Submaster bump button dwell fade times. Hold causes a faded submaster to stay active until you press the bump button again. A flashing LED indicates that a submaster is holding. Hold causes an effect to hold until you press the clear button controlling the effect to fade the effect out.

## **Hold (fader)**

Use the fader [Hold] to interrupt a fade. Press [Go] to resume, or [Hold] to cancel the fade execution.

Example: [Cue] [5] [Go] [Hold] [Go] starts cue 5, pauses it, then resumes its fade.

## **Hold-for-Go (subroutine)**

A subroutine runs through steps until it reaches a Hold-for-go step. It then pauses until you press [Go].

## **In/Dwell/Out**

### ***In/Dwell/Out is softkey [S3] after [S7], More Softkeys, in the Blind Effect display***

Use [S3], **In/Dwell/Out**, to access the fade time field for selected step(s). The first time value is the fade in-time, the second is the dwell time, and the third is the fade out-time for the step. Alternatively, the arrow buttons can be used to move through the display.

Example: [Step] [6] [S3], **In/Dwell/Out**, [1] [→] [2] [→] [1] sets an in time of one second, a dwell of two seconds and an out time of one second for step 5.

## **Independent**

### ***Independent is softkey [S1] in the Link List display***

Use [S1], **Independent**, to mark a channel independent. Independent channels are not affected by the Grandmaster, Blackout, Solo, or Flash.

## **Independent channels**

An independent channel is not affected by the Grandmaster, Blackout, Solo, or Flash keys. Otherwise, independent channels function normally. You may set a channel as independent in the Link List display. Press [Rel] three times to release independent channels.

## **Inhibitive submaster**

Inhibitive submasters allow you to limit the intensity level for a group of channels. An inhibitive submaster doesn't actually set channel levels, it prevents channel outputs from exceeding a specified level. When an inhibitive submaster is set at **10** (100 percent), channel output is not inhibited. As you pull the slider down, channel outputs are limited to the level at which you set the slider. An inhibitive submaster controls the levels of its assigned channels in the same way the Grandmaster controls the levels of all channels. Only submasters 73 through 108 may be inhibitive. An inhibitive submaster's LED is red.

*Remember, leave inhibitive submasters at **10** (100 percent) unless you want to inhibit channels. Otherwise channels may be missing from your cues. If channels are missing, or channel levels have changed, check your inhibitive submasters! If a channel is fully inhibited by a submaster, its level will be displayed as a yellow zero.*

## ***Insert Event***

***Insert Event is softkey [S1] after [S7], More Softkeys, in the SMPTE Events display***

Use [S1], **Insert Event**, to insert SMPTE events between two existing events. The events will be inserted ahead ahead of the selected event.

## ***Insert Program***

***Insert Program is softkey [S1] after [S7], More Softkeys, in the Real Time Programs display***

Use [S1], **Insert Program**, to insert an empty program number ahead of the selected or specified program. All subsequent programs are renumbered.

## ***Insert/Replace***

***Insert/Replace is softkey [S2] in the Macro Editing and Designer's Worksheet Editing displays***

Press [S2], **Insert/Replace**, to change the editing mode of the macro display. Replace Mode overwrites macro entries, and Insert Mode inserts new entries before the currently selected entry (displayed in yellow.)

## ***Insert Step***

***Insert Step is softkey [S5] after [S7], More Softkeys, in the Blind Effect and Blind Subroutine displays***

Press [S5], **Insert Step**, to insert an empty step ahead of the selected or specified step.

Example: [[S5], **Insert Step**, [Enter] [Enter] places an empty step in front of the selected step.

Example: [S5], **Insert Step**, [5] [Enter] [Enter] places an empty step in front of step 5.

## ***Internal Clock***

***Internal Clock is softkey [S1] in the SMPTE Events display***

Use [S1], **Internal Clock**, to set the SMPTE internal clock. This clock serves as a backup for SMPTE input, and will execute the SMPTE event list if the SMPTE input drops out. The internal clock may also be used to run the SMPTE events without any SMPTE input. The SMPTE time clock is displayed in green when SMPTE input is active. It is displayed in red when the internal clock is active.

## ***Jump-to-cue (subroutine)***

A subroutine runs through steps until it reaches a Jump-to-cue step. It then automatically starts another cue which is not included in the subroutine. You can jump to any type of cue: regular, subroutine or effect.

When you create the Jump to cue step, enter the number of the cue to which to jump.

## ***Keypad Numbers***

Use the keypad number keys to enter all numeric information (dimmers, channels, cues, times, intensities, etc.).

## ***Label***

Use [Label] to assign an alphanumeric label to a cue, group or submaster.

Example: [Cue] [6] [Label] [Act 1.1] [Enter] names cue 6 **Act 1.1**.

## ***Label***

***Label is softkey [S3] in the Channel Attributes display and [S5] in the Real Time Programs display***

Use [S3] or [S5], **Label**, to assign a label to a channel or a program.

## ***Last Page***

***Last Page is softkey [S4] in many displays***

Press [S4], **Last Page**, to go backward one display page. After software version 1.8, this key is renamed **Previous Page**.

## ***Learn (Macro)***

Insight 2's Learn function allows you to create a macro by performing an actual sequence of keystrokes. Insight 2 records the keystrokes you execute in a macro. The recorded keystroke sequence can then be rerun by pressing the appropriate macro key. Once you record a macro in Learn mode you can edit the sequence in Macro mode to adjust its operation.

Example: [Learn] [M3] [Enter] starts the macro Learn process for macro 3.

## ***Learn mode (SMPTE)***

***Learn Mode is softkey [S6] in the SMPTE Events display***

Use [S6], **Learn Mode**, to record SMPTE events from the fader [Go] keys, the submaster bump buttons or the macro keys. To insert an event time only, go to SMPTE display mode and press [Record]. Press [S6] again to turn off Learn mode. Learned events will not be sorted and permanently stored until Learn mode is turned off.

## **Left Arrow**

Use [←] to move through various displays, including Stage, Blind, effects, subroutines and macros.

## **Level**

Use [Level] to immediately set channels and groups to the default level assignment determined in the Setup menu.

Example: [Channel] [6] [Level] sets channel 6 to the default level.

## **Level Wheel**

Use the level wheel to proportionally adjust a selected group of channels.

Example: [Channel] [1] [Thru] [5] [Level Wheel] sets the levels for channels 1 through 5.

Example: [Group] [5] [Level Wheel] sets the level on all channels in group 5.

## **Link**

Use [Link] to cause the linked cue to be loaded as the next available cue, to link a macro execution to a cue or to select a link in the Link List.

Example: [Cue] [1] [Link] [8] links cue 8 to cue 1.

Example: [Cue] [6] [Link] [Enter Macro] [4] [Enter] links macro 4 to cue 6.

## **Load Check**

### ***Load Check is softkey [S4] in the Load Management display***

Use [S4], **Load Check**, to compare the current load on selected dimmers with their recorded loads.

## Low/High

**Low/High is softkey [S4] after [S7], More Softkeys, in the Blind Effect display**

Use [S4], **Low/High**, to access the level field for the selected step(s). The first value is the low level to which the step elements will be set, the second value is the high level for those elements.

Example: [Step] [4] [Thru] [8] [S4], **Low/High**, [0] [→] [9] [Enter] sets the low level for steps 4 through 8 to zero and the high level to 90 percent.

## Loop (subroutine)

A subroutine runs through steps until it reaches a Loop step. It then returns to first step, and repeats the sequence for the number of times you specify.

When you create the Loop step, enter the number of times you want the loop to return to the top of the step list. If you enter **5**, the sequence will play six times. Enter **0** to create a continuous loop.

## M1-M5

Use macro keys [M1]-[M5] to immediately execute the associated macro instructions.

## M\*

Analogous in function to macro keys [M1]-[M5] (used for macros 1-5). [M\*] is used for macros 6 and higher. Press [M\*], then enter macro number and press [Enter].

## Macro

A macro allows you to store a series of keystrokes and later replay it with one or two keystrokes. Macros simplify complex tasks that you perform often. You can program up to 2,000 macros in Insight 2, depending on how large they are.

## Macro (Real Time/SMPTE)

**Macro is softkey [S4] in the Real Time Programs display and [S6] after [S7], More Softkeys, in the SMPTE Events display**

Use [S4] or [S6], **Macro**, to access a macro to run as part of a program or event.

## Macro Wait

Use [Macro Wait] to place a pause in the macro execution. The Macro Wait instruction may be placed in the macro as many times as required.

Example: [Learn] [M4] [Enter] [Dim] [1] [At] [7][5] [Macro Wait] [5] [Enter] [M5]

## Manual

If a submaster has a manual dwell, its upfade starts when you press and hold the bump button. It runs until channels reach full recorded levels, then holds at full as long as you hold the bump button; the downfade begins when you release it. Therefore, if you don't hold the bump button for the duration of the upfade time, channels do not reach their full recorded levels.

*Note: If you do not enter a dwell time for a submaster, the submaster defaults to a manual dwell.*

## Manual Mode

### **Manual Mode is softkey [S3] in the SMPTE Events display**

Use [S3], **Manual Mode**, to interrupt the input of SMPTE time code, and to reset the SMPTE event list to the first recorded event. Press again to return to normal operation. SMPTE events may be individually executed in Manual mode by pressing [Step].

## Minus

Use [-] to decrease the selected number by one.

Example: [Cue] [4] [-] selects cue 3.

Example: [Dim] [6] [At] [7][5] [-] [-] patches dimmer 6 at 73 percent.

## More Softkeys

### **More Softkeys is softkey [S7] in many displays**

When a display has more than eight softkeys, the console displays a softkey labeled [S7], **More Softkeys**. Press [S7] to display additional softkeys.



## Move Event

### **Move Event is softkey [S3] after [S7], More Softkeys, in the SMPTE Events display**

Use [S3], **Move Event**, to move a group of SMPTE events. The target time of the first event in the group must be specified. The original spacing of subsequent events will be maintained.

## Move Program

**Move Program is softkey [S3] after [S7], More Softkeys, in the Real Time Programs display**

Use [S3], **Move Program**, to move a group of programs. The target time of the first program in the group must be specified. The original spacing of subsequent programs is maintained.

## Moving channels

Moving channels are channel levels that change from one cue to the next. In Stage mode, all moving channels are displayed in green. In Blind, moving channels are displayed in green if they are moving down or blue if they are moving up.

## Multipart cue

A multipart cue consists of up to eight parts, each of which is essentially an independent cue with its own channel levels and timing information. Parts accept most standard cue attributes, with the exception of Follow and Label, which apply only to the overall cue. You may record a cue as a multipart cue, or record it as a standard, one-part cue and split it later.

Each part of a multipart cue may consist of any number of channels, but a channel may only be included in one part of a multipart cue. If you record a channel in a part and that channel is already included in another part, the channel will be placed in the new part and be removed from the older part automatically.

## Multiplex

**Multiplex is softkey [S1] in the Patch and System Status displays**

[S1], **Multiplex**, allows a range of dimmers to be used with ETC Source Four multiplexers. A and B outputs will be created for each multiplex dimmer, which may be patched to discrete control channels. Multiplex assignments may be given only to dimmers on a DMX512 port that has been set for multiplex in the I/O Configuration menu.

## Next Page

**Next Page is softkey [S5] in many displays**

Press [S5], **Next Page**, to go forward one display page.

## Off Sub-Bump

**Off Sub-Bump is softkey [S2] after [S7], More Softkeys, in the Macro Editing and Designer's Worksheet Editing displays**

Use [S5], **Off Sub-Bump**, in a macro instruction to force the submaster off via the submaster bump button. The downfade will occur in the downfade time for that bump button. Use the actual submaster bump button or the keypad when recording the macro.

Example: [Select Macro] [5] [Enter] [S5], **Off Sub-Bump**, Submaster 1's bump button, [Enter Macro] creates a macro that downfades submaster 1.

## **On Sub-Bump**

**On Sub-Bump is softkey [S1] after [S7], More Softkeys, in the Macro Editing and Designer's Worksheet Editing displays**

Use [S4], **On Sub-Bump**, in a macro instruction to force the submaster on via the submaster bump button. The upfade will occur in the upfade time for that bump button. Use the actual submaster bump button or the keypad when recording the macro. The submaster will fade out after the dwell time has elapsed, unless it is programmed with a hold.

## **Only**

Use [Only] to select a subset of the currently selected channels.

Example: [Group] [2][5] [And] [2][6] [Only] [Group] [5] [At] [7][5] [Only] [Group] [1][0] [At] [5][0] takes all the channels that are in group 25 and 26, sets those channels that are also in group 5 to 75 percent, and sets those that are also in group 10 to 50 percent.

## **Page**

Use [Page] to load a different page into the submasters. Active submasters will hold their current look until the associated slider has been returned to its home position (zero for pile-on or effect submasters, **10** for inhibitive submasters).

Example: [Page] [2] [Enter] loads submaster page 2.

## **Park**

**Park is softkey [S6] in the Stage and Fader displays**

Press [S6], **Park**, set a dimmer, channel or group at a specified level. Parked dimmers, channels or groups will remain at their park level until unparked.

## **Part**

Use [Part] to break a cue into multiple fades. Each cue may contain up to eight parts. A wait time may be assigned to each part to hold the start of that part. A cue may be recorded as a multipart cue or may be broken into multiple parts at a later time. A channel may be in only one part.

Example: [Stage] [15] [Record] [5] [Part] [1] [Enter] records channel 15's current level into part 1 of cue 5.

## **Patch**

The Patch display provides a list of dimmer-to-channel assignments, with associated proportional levels and profiles.

## ***Pause Mode***

### ***Pause Mode is softkey [S4] in the SMPTE Events display***

Use [S4], **Pause Mode**, to interrupt the input of SMPTE time code, without resetting the SMPTE event list. Press again to return to normal operation. SMPTE events may be individually executed in Pause mode by pressing [S5], **Step**.

## ***Pause Printer***

### ***Pause Printer is softkey [S2] in the Print Functions display***

Press [S2], **Pause Printer**, to interrupt a print function. Press [S2] again to resume printing.

## ***Pile-on submaster***

A pile-on submaster contains a specified set of channels, recorded at proportional levels. Pile-on submasters interact with established channel levels on a highest level basis.

## ***Play Backup***

### ***Play Backup is softkey [S2] in the System Status display***

Use [S2], **Play Backup**, to play back a recording of a selected look on stage that is stored in a Sensor CEM.

## ***Plus***

Press [+] to increase the selected number by one.

Example: [Cue] [6] [Time] [1][0] [+] [+] sets the fade time for cue 6 to 12 seconds.

Example: [Dim] [1] [At] [7][5] [+] [+] patches dimmer 1 at 77 percent.

## ***Positive/Negative***

### ***Positive/Negative is softkey [S1] in the Blind Effect Attribute display***

Press [S1], **Positive/Negative**, to change the effect attribute from a positive chase (steps are at their low value when off and their high level when on) to a negative chase (steps are at their high level when off and their low level when on). All effects must have either the positive or negative attribute assigned (all other attributes are optional).

## ***Previous Page***

### ***Previous Page is softkey [S4] in many displays***

Press [S4], **Previous Page**, to go backward one display page.

## ***Print Screen***

### ***Print Screen is softkey [S1] in the Load Management display***

Press [S1], **Print Screen**, to print a list of dimmer load errors.

## Profile

### **Profile is softkey [S7] in the Patch display**

Press [S7], **Profile**, to assign one of 10 profiles to a dimmer. A dimmer may be assigned a proportional patch level or a profile.

Example: [Dim] [6] [S7], **Profile**, [4] [Enter] assigns profile 4 to dimmer 6.

## Purge Flexi

### **Purge Flexi is softkey [S1] in the System Settings display**

Press [S1], **Purge Flexi**, to recalculate the list of channels used in Flexi-channel mode. This also happens automatically when you load a show from disk or when you turn Flexichannel on.

## Quickstep

### **Enable/Disable Quickstep is softkey [S1] after [S7], More Softkeys, in the Stage and Fader displays**

[S1], **Quickstep**, allows you to run through a show, checking all cues, without having to wait for fades. When Quickstep is active, the faders ignore all upfade, downfade, and wait times. Cues snap immediately to their completed levels when you press [Go] or [Back]. Disable Quickstep mode by pressing [S7] again, or by leaving the Stage display.

## Rack Status

### **Rack Status is softkey [S6] in the System Status and Dimmer Status displays**

Use [S6], **Rack Status**, to check information about your dimmer racks, including rack type, starting address, port information, voltage, frequency, and ambient temperature.

## Random

### **Random is softkey [S6] in the Blind Effect Attribute display**

Use [S6], **Random**, to cause the step list execution to be selected and run randomly. To cancel the Random attribute, press [S6] again.

## Random Rate

### **Random Rate is softkey [S7] in the Blind Effect Attribute display**

Press [S7], **Random Rate**, to cause the rate to be randomly selected and applied to each step. The selection will be within the range defined for Low random rate and High random rate. Rates may range from 0 to 2,000. To cancel the Random Rate attribute, press [S7] [Clear].

Example: [S7], **Random Rate**, [5][0] [[S7], **Random Rate**, 2][0][0] to set the minimum rate to 50 percent and the maximum rate to 200 percent.

## Rate (fader)

Press the fader's [Rate] key to allow the fader rate to be controlled by the rate wheel.

Example: [A/B Rate] [Rate Wheel] adjusts the rate of the fade in fader A/B.

## **Rate**

### **Rate is softkey [S3] in the Stage, Blind, Fader and List displays**

Use [S3], **Rate** to edit the rate for a cue, submaster, multipart cue, effect, or subroutine. Also use [S3], **Rate**, to place the timing for a submaster under rate wheel control.

Example: [S3], **Rate**, [Sub Bump 3] followed by adjustment of the rate wheel modifies submaster 3's fade times.

## **Rate (SMPTE)**

### **Rate is softkey [S4] after [S7], More Softkeys, in the Dimmer Status display**

Use [S4], **Rate**, to access the rate fields in the SMPTE Events display. Press once to select the A/B cue rate, Press again to select the C/D cue rate and press once more to select the submaster rate.

## **Rate Wheel**

Use the wheel, when one of the fader [Rate] keys is active, to alter the rate of fades.

Example: Press [AB Rate] then move the wheel to adjust the fade rate of the cue in the A/B fader.

## **Record**

Use [Record] to save all cue, submaster or group information in console memory

Example: [Record] [6] [Time] [3] [Enter] records cue 6 and sets its fade time to 3 seconds.

Example: [1] [Thru] [6] [Record] [Sub Bump 1] records channels 1 through 6 to submaster 1.

## **Record Backup**

### **Record Backup is softkey [S3] in the System Status display**

Use [S3], **Record Backup**, to store a recording of a selected look on stage in a Sensor CEM. You may record up to 32 backup looks.

## **Record Loads**

### **Record Loads is softkey [S5] in the Load Management display**

Use [S5], **Record Loads**, to record load information for all dimmers set at a level above zero. Choose the dimmers you wish to record, set them to a level, then run Record Loads.

## **Record Lockout**

You may set the console to disable the Record function. This protects a finished show from inadvertent changes.

To disable the Record function in your system, press [Setup] [1] [Enter] [1][3] [Enter] [1] [Enter].

## **Recorded channels**

Recorded channels are channel levels that have been recorded in a cue, group or submaster. In Stage mode, recorded levels are displayed in green or magenta. Recorded channels may be either moving or tracked in Blind mode. Channel levels controlled by effects are displayed in white. Except for effect submasters, channel levels controlled by submasters are displayed in yellow. Channel levels set by channel sliders are displayed in gold

## **Release**

Use [Rel] to release selected, captured, and independent channels from the control of the keypad in Stage, Blind or Tracksheet modes. First press releases any selected channels, second releases captured channels, and third releases independent channels.

Example: [Channel] [5] [At] [7][5] [Rel] sets channel 5 at 75 percent, then releases it.

## **Replace/Insert**

**Insert/Replace is softkey [S2] in the Macro Editing and Designer's Worksheet Editing displays**

Press [S2], **Insert/Replace**, to change the editing mode of the macro display. Replace Mode overwrites macro entries, and Insert Mode inserts new entries before the currently selected entry (displayed in yellow.)

## **Reset Loop**

**Reset Loop is softkey [S8] after [S7], More Softkeys, in the SMPTE Events display**

Use [S8], **Reset Loop**, to set the first and last valid SMPTE frames for the SMPTE program, so that the internal clock can correctly reset to the starting frame.

## **Reset System**

**Reset System is softkey [S1] in the Clear Functions display**

Use [S1], **Reset System**, to clear all data from console and reset all settings to factory defaults.

## **Return**

**Return is softkey [S8] in numerous displays**

Use [S8], **Return**, to return to the previous display.

## **Reverse**

### ***Reverse is softkey [S3] in the Blind Effect Attribute display***

Use [S3], **Reverse**, to cause the effect step list to run in reverse order, beginning with the last recorded step. To cancel the reverse attribute, press [S3] again.

## **Right Arrow**

Press [→] to move through various displays, such as Stage, Blind, effects, and macro mode.

## **Select Cue**

### ***Select Cue is softkey [S3] after [S7], More Softkeys, in the Blind Subroutine display***

Press [S3], **Select Cue**, to create or edit a fade step in a subroutine cue.

## **Select Dimmer**

### ***Select Dimmer is softkey [S5] in the Dimmer Status display***

Use [S5], **Select Dimmer**, to select a specific dimmer on the Dimmer Status display.

## **Select Event**

### ***Select Event is softkey [S1] after [S7], More Softkeys, in the Dimmer Status display***

Use [S1], **Select Event**, to select a SMPTE event or a range of SMPTE events for modification.

## **Select Fader**

### ***Select Fader is softkey [S1] in the Fader display***

Press [S1], **Select Fader**, to view the live output levels of the cues in the A/B fader, the C/D fader, both faders, or the DMX In levels.

## **Select Group**

### ***Select Group is softkey [S1] in the Blind Group display***

Use [S1], **Select Group**, to specify which group to edit or view.

Example: [Blind] [Group] [S1], **Select Group**, [6] [Enter] brings up group 6 for editing.

## **Select Macro**

### ***Select Macro is softkey [S1] in the Macro Editing display***

Use [S1], **Select Macro**, to access a macro for recording or editing.

Example: [S1], **Select Macro**, [6] [Enter] selects macro 6.

## Select Program

**Select Program is softkey [S1] in the Real Time Programs display**  
Use [S1], **Select Program**, to choose a program for editing.

## Select Rack

**Select Rack is softkey [S6] in the Rack Status display**  
Use [S6], **Select Rack**, to select a specific rack on the Rack Status display.

## Select Region

**Select Region is softkey [S1] in the Designer's Worksheet Editing display**  
Use [S1], **Select Region**, to access a macro for recording or editing.

Example: [S1], **Select Region**, [6] [Enter] selects worksheet region 6.

## Selected channels

Selected channels are channels over which you have immediate keyboard control. You can modify selected channels with [Full], [At], [+], [-], or the fader wheel. Selected channels are displayed in yellow, and their levels are red on white. You can select channels in most display modes.

*Selected, captured* channels are *live* channels that are under immediate keypad control. Channels can be *selected and captured* only in Stage modes. You can select channels in Blind, but they won't be captured since Blind mode is not live. Press [Rel] once to release selected channels.

## Set Clock

**Set Clock is softkey [S2] in the Setup display**  
Use [S2], **Set Clock**, to set the real time clock to correct time and date.

## Set Dimmer

**Set Dimmer is softkey [S7] in the ETCLink Functions display**  
Use [S7], **Set Dimmer**, to set a dimmer or group of dimmers to a level at the rack, ignoring any DMX512 levels. This requires a system connected by ETCLink to a Sensor dimming system.

## Setup

The Setup display allows you to access system setting information, print and disk functions, and macro editing, as well as optional control information.



## Sheet Sliders/Console Sliders

**Sheet Sliders/Console Sliders is softkey [S1] in the Designer's Worksheet Setup display**

Use [S1], **Sheet Sliders/Console Sliders**, to enable either the sliders on the console, or the sliders on the Designer's Worksheet.

## Show/Hide Labels

**Show/Hide Labels is softkey [S8] in the Patch display**

Press [S8], **Show Labels**, in Patch mode to display or hide the alphanumeric dimmer labels.

## Show Name

**Show Name is softkey [S1] in the Setup display**

Press [S1], **Show Name**, to label the show in memory, using the alphanumeric keyboard. The show name will be stored with the show when written to disk.

## SMPTE Time

**SMPTE Time is softkey [S2] after [S7], More Softkeys, in the Dimmer Status display**

Use [S2], **SMPTE Time**, to access the time field in the SMPTE Events display.

## **Sneak**

### ***Sneak is softkey [S1] in the Stage display***

Use Sneak to return modified channels to the level provided by the faders or submasters. Channels will fade in the Sneak time established in the Setup menu unless a time is specified. Channels may also 'Sneak' to a specified level

Example: [1] [S1], **Sneak**, [Enter]

Example: [1] [At] [7][5] [S1], **Sneak**, [Time] [5] [Enter]

## **Solo**

Use [Solo] to clear non-selected channels. In Live mode, press again to restore channels to previous setting.

Example: [Channel] [1] [Thru] [1][0] [Solo] sets the levels of all channels other than channels 1 through 10 to zero.

## **Solo Bump**

Press [Solo Bump] to put the submaster bump buttons into Solo mode. The LED inset into the key lights to indicate that Solo mode is active. in Solo mode, pressing any submaster bump button brings its channels to their recorded level (or brings its channel to Full if in Channel mode) and takes all other channels to zero.

## **Sort**

### ***Sort is softkey [S8] after [S7], More Softkeys, in the SMPTE and Real Time Programs displays***

Use [S8], **Sort**, to reorder SMPTE events or Real Time Programs by time. The system will automatically conduct a sort when the mode is exited, or when moving, copying or deleting events or programs.

## **Stage**

The Stage display represents the current live channel levels as set by the keypad, faders and submasters combined.

## **Step (Effect/Subroutine)**

### ***Step is softkey [S1] in the Blind Effect and Blind Subroutine displays***

Press [S1], **Step**, to select a step or range of steps for modification.

Example: [S1], **Step**, [1] [Enter] selects step 1.

Example: [S1], **Step**, [5] [Thru] [9] [Enter] selects steps 5 through 9.

## **Step (SMPTE)**

### ***Step is softkey [S5] in the SMPTE Events display***

Use [S5], **Step**, to execute the next SMPTE event in the event list. System must be in SMPTE manual or pause mode.

## **Steps, effect**

An effect may consist of up to 100 steps. A step is made up of channels or groups, also known as elements. A step may contain up to ten elements. For example, channels 1 through 10 would constitute ten elements, filling the step. However, a group containing channels 1 through 10 would constitute only one element, allowing nine more channels or groups to be added.

Each step in an effect is assigned a high and low level, a step time, and an in, dwell, and out time.

## **Steps, subroutine**

All subroutine steps are either cue steps or style steps. A cue step contains an existing recorded cue. The subroutine lets you change levels and fade rates for the cue step without changing the original cues. A cue step may contain an effect cue.

A style step contains an instruction that controls the subroutine's playback pattern. This allows you to run loops, run bounces, pause the subroutine until you press go, or end the subroutine and jump to any other cue.

## **Step Time**

**Step Time is softkey [S2] after [S7], More Softkeys, in the Blind Effect display**

Press [S2], **Step Time**, to access the Time field for the selected step(s). Step time is the time between the activation of the selected step and the next step. Alternatively, the arrow keys can be used to move through the display.

Example: [Step] [5] [S2], **Step Time**, [.] [2] [Enter] sets the step time of step 5 to .2 seconds.

## **Stop Printer**

**Stop Printer is softkey [S1] in the Print Functions display**

Press [S1], **Stop Printer**, to cancel a print function. It may take a few moments for the printer to halt if its buffer is full.

## **Style**

**Style is softkey [S2] after [S7], More Softkeys, in the Blind Subroutine display**

Use [S2], **Style**, to select or edit the style of a subroutine control step.

## **Style steps (subroutine)**

A style is assigned to a subroutine step. When the subroutine runs, the steps play back in numeric order, until the subroutine reaches a style step. The style step then determines whether the subroutine will loop, bounce, hold, or end and run a different cue.

Press [Style] to select or edit the style of a subroutine control step.

Example: [Step] [5] [Style] [1] [Enter] sets the style of step 5 to loop.

## **Sub**

Use [Sub] to select a submaster number.

Example: [Record] [Sub] [1] [Enter] records the current look in submaster 1.

Example: [Group] [Sub] [1] [At] [7][5] sets the channels in submaster 1 at 75 percent of their recorded levels

## **Sub List**

### ***Sub List is softkey [S2] in the Blind Submaster displays and [S3] after More Softkeys in the Stage Display***

Use [Sub List] to access the Submaster List display, which provides a list of submasters, their fade times and labels

## **Submaster**

A submaster consists of a slider, a bump button and one or two LEDs. The slider allows you to bring the submaster look up manually. The bump button allows you to flash the submaster to its full recorded level or to begin its programmed fade, if it has one. The LEDs show you which submasters are recorded and whether the submasters in the bottom row are pile-on or inhibitive.

A channel may be included in as many submasters as you choose. You can record up to 108 submasters in each of ten pages of submaster memory, for a total of 1,080.

## **Submaster bump buttons**

Use a submaster bump button to drive the assigned channels to their recorded levels in the recorded fade time. This button may also be used when recording a submaster look.

Example: [Record] [Sub Bump 4] records the current look into submaster 4.

Example: [Update] [Sub Bump 1] records the channels in the current look that are also in submaster 1 at their current levels.

## **Sub Mode**

Submaster bump buttons may be set in Channel or Submaster modes.

### **Submaster mode**

Press the [Sub Mode] key to switch the submaster bump buttons into Submaster mode. The submasters recorded in the console's submaster memories are loaded into the submaster sliders. Each submaster slider and bump button now controls its assigned submaster.

### **Channel mode**

Press the [Sub Mode] key again to switch the submaster bump buttons into Channel mode. In channel mode, each submaster slider and bump button controls the correspondingly numbered channel, i.e., slider 1 controls channel 1, slider 2 controls channel 2 and so forth.

## **Subroutine**

A subroutine is a cue that controls the playback of a series of existing, recorded cues. Subroutines are similar to linked cues, except that they have more playback options.

Subroutines and effects can create similar looks. However, subroutines have some advantages over effects. Since each step of a subroutine is a cue with proportional levels, you can create loops or chases with proportional looks. You can also create nested loops, or even use an effect cue as a step in a subroutine.

Also, since subroutine steps are actual cues, there is no limit to the number of channels you can use.

## **Suppress Labels**

### **Suppress Labels is softkey [S4] in the Patch display**

Use [S4], **Suppress Labels**, in patch mode to hide the display of the dimmer labels. Softkey then reads **Show Labels**.

## **System Status**

### **System Status is softkey [S4] in the Rack Status and Dimmer Status displays**

Use [S4], **System Status**, to check information about your Sensor dimming system, including system firing mode, current backup look status, ETCLink errors, and system configuration.

## **Thru**

Use [Thru] to select a continuous group of dimmers or channels.

Example: [Channel] [1] [Thru] [5] [And] [8] [At] [7][5] sets channel 1 through 5 and channel 8 to 75 percent.

## ***Time***

Use [Time] to enter upfade and downfade times for cues and submasters.

Example: [Cue] [6] [Time] [5] [Enter] [1][0] sets cue 6's upfade to five seconds and its downfade to ten seconds.

Example: [Cue] [7] [Time] [3] [Time] [5] [Enter] sets cue 7's upfade to three seconds and its downfade to five seconds.

## ***Time***

### ***Time is softkey [S2] in the Real Time Programs display***

Use [S2], **Time**, to go to the time field for editing.

## ***Track***

Use [Track] to record channel levels that are to be tracked into subsequent cues.

Example: [Cue] [5] [Track] [Enter] tracks channels from cue 5 into following cues.

## ***Tracked channels***

A tracked channel is a channel whose level is unchanged from the preceding cue. Tracked channels are displayed in magenta.

## ***Tracksheet display***

Tracked channels are channels whose levels do not change from one cue to the next. Tracksheet allows you to display one channel's settings for all recorded cues. At a glance you can see which cues have tracking levels for that particular channel. You can also use Tracksheet to add or modify a tracked channel through recorded cues.

To display Tracksheet, press [Tracksheet]. If more cues are recorded than fit on one screen, press [S5], **Next Page**, to display the next screen of cues.

Example: [Tracksheet] [Channel] [5] [Enter] [Cue] [1] [At] [7][5] [Record] [Enter] records channel 5 at 75 percent in cue 1.

## ***Type***

Use [Type] to select the fade type for a cue, or the submaster type for a submaster.

Example: [Blind] [Cue] [4] [Type] [3] [Enter] makes cue 4 an effect cue.

Example: [Blind] [Sub] [6] [Type] [2] [Enter] makes submaster 6 inhibitive.

## Type/Level

### **Type/Level is softkey [S4] after [S7], More Softkeys, in the Blind Subroutine display**

Press [S4], **Type/Level**, to select between crossfade and allfade steps in a subroutine cue. Press again to specify a final fade level of less than 100%.

Example: [Step] [1] [S4], **Type/Level**, [2] [Enter] sets the step as an allfade cue.

Example: [Step] [3] [Select Cue] [8] [S4], **Type/Level**, [S4], **Type/Level**, [5][0] will fade cue 8 to 50 percent of its recorded level.

## Unpatch

### **Unpatch is softkey [S6] in the Patch display**

Use [S6], **Unpatch**, to unpatch (patch to channel 0) selected dimmers.

Example: [Dimmer] [5] [S6], **Unpatch**, [Enter] unpatches dimmer 5.

Example: [S6], **Unpatch**, [Dimmer] [7] [Enter] unpatches dimmer 7.

## Unset Dimmer

### **Unset Dimmer is softkey [S6] in the ETCLink Functions display**

Use [S6], **Unset Dimmer**, to return a dimmer or group of dimmers to normal dimming. This requires a system connected by ETCLink to a Sensor dimming system.

## Up Arrow

Use [↑] to move through various displays, such as Stage, Blind, effects and macro mode.

## Up/Down/Follow

### **Up/Down/Follow is softkey [S8] after [S7], More Softkeys, in the Blind Subroutine display**

Use [S8], **Up/Down/Follow**, to assign upfade and downfade times and to specify amount of time to hold before beginning the next subroutine step.

Example: [Step] [1] [S8], **Up/Down/Follow**, [2] [S8], **Up/Down/Follow**, [4] [S8], **Up/Down/Follow**, [5] [Enter] assigns an upfade time of two seconds and a downfade time of four seconds to step 1. Step 2 will start five seconds after step 1 starts.

## **Update**

### **Update is softkey [S2] in the Stage and Fader displays**

Press [S2], **Update**, to re-record active submasters, cues and groups as a selective record. Modified levels are recorded into the source and control is simultaneously returned.

Example: [S2], **Update**, [Sub] [1] [Enter] records submaster 1 with any modified channels originally controlled by submaster 1. Channel control is restored to submaster 1.

## **Wait**

Use [Wait] to hold the start of the upfade or downfade, to accomplish lag/lead type cues. The first wait will hold the upfade, the second will hold the downfade. The wait time (0 to 99:59) will begin counting when the cue is activated.

Example: [Cue] [5] [Time] [6] [Wait] [6] [Enter] sets cue 5 to wait six seconds before starting a six second upfade.

Example: [Cue] [7] [Wait] [Wait] [5] [Enter] sets cue 7 to wait five seconds before starting the downfade.

## **Wheel**

Use the wheel to proportionally adjust the levels of a selected group of channels. Also may be used as a rate wheel, when fader [Rate] key is active, to alter the rate of fades.

Example: [Channel] [1] [Thru] [5] [Wheel] adjusts the levels of channels 1 through 5.

Example: [AB Rate] [Wheel] adjusts the rate of the fades in the A/B fader.

# appendix e

## softkeys

The following charts show all available softkeys on Insight 2 consoles using software version 2.0.

### **Stage**

- 1 - Sneak
- 2 - Update
- 3 - Rate
- 4 - Previous Page
- 5 - Next Page
- 6 - Park
- 7 - More Softkeys → *Stage 2*
- 8 - Flash

### **Blind Cue**

- 1 -
- 2 - Cue List → *Cue List*
- 3 - Rate
- 4 - Previous Page
- 5 - Next Page
- 6 - Delete Cue
- 7 -
- 8 -

### **Blind Multipart**

- 1 -
- 2 - Cue List → *Cue List*
- 3 - Rate
- 4 - Previous Page
- 5 - Next Page
- 6 - Delete Part
- 7 -
- 8 -

### **Blind Group**

- 1 - Select Group
- 2 - Group List → *Group List*
- 3 -
- 4 - Previous Page
- 5 - Next Page
- 6 - Delete Group
- 7 -
- 8 -

### **Blind Submaster**

- 1 - Bump Status
- 2 - Sub List → *Sub List*
- 3 - Rate
- 4 - Previous Page
- 5 - Next Page
- 6 - Delete Sub
- 7 -
- 8 -

### **Stage 2**

- 1 - Enable/Disable Quickstep
- 2 -
- 3 - Sub List
- 4 - Previous Page
- 5 - Next Page
- 6 - Delete
- 7 - More Softkeys → *Stage*
- 8 - DMX In

### **Cue List**

- 1 -
- 2 -
- 3 - Rate
- 4 - Previous Page
- 5 - Next Page
- 6 - Delete Cue
- 7 -
- 8 - Return → *Blind Cue*

### **Group List**

- 1 -
- 2 -
- 3 -
- 4 - Previous Page
- 5 - Next Page
- 6 - Delete Group
- 7 -
- 8 - Return → *Group*

### **Sub List**

- 1 - Bump Status
- 2 - Hold
- 3 - Rate
- 4 - Previous Page
- 5 - Next Page
- 6 - Delete Sub
- 7 -
- 8 - Return → *Submaster*

**Blind Cue Effect**

- 1 - Step
- 2 - Cue List → *Cue List*
- 3 - Rate
- 4 - Previous Page
- 5 - Next Page
- 6 - Delete Cue
- 7 - More Softkeys → *Effect 2*
- 8 -

**Blind Sub Effect**

- 1 - Bump Status
- 2 - Sub List → *Sub List*
- 3 - Rate
- 4 - Previous Page
- 5 - Next Page
- 6 - Delete Sub
- 7 - More Softkeys → *Effect 2*
- 8 -

**Blind Subroutine**

- 1 - Step
- 2 - Cue List → *Cue List*
- 3 - Rate
- 4 - Previous Page
- 5 - Next Page
- 6 - Delete Cue
- 7 - More Softkeys → *Subr2*
- 8 -

**Fader**

- 1 - Select Fader
- 2 - Update
- 3 - Rate
- 4 - Previous Page
- 5 - Next Page
- 6 - Park
- 7 - More Softkeys → *Fader 2*
- 8 -

**Tracksheet**

- 1 -
- 2 -
- 3 -
- 4 - Previous Page
- 5 - Next Page
- 6 -
- 7 -
- 8 -

**Patch**

- 1 - Multiplex
- 2 - A
- 3 - B
- 4 - Previous Page
- 5 - Next Page
- 6 - Unpatch
- 7 - Profile
- 8 - Show/Hide Labels

**Effect 2**

- 1 - Step
- 2 - Step Time
- 3 - In/Dwell/Out
- 4 - Low/High
- 5 - Insert Step
- 6 - Delete Step
- 7 - More Softkeys → *Effect*
- 8 - Attribute → *Attributes*

**Subr 2**

- 1 - Step
- 2 - Style
- 3 - Select Cue
- 4 - Type/Level
- 5 - Insert Step
- 6 - Delete Step
- 7 - More Softkeys → *Blind Subroutine*
- 8 - Up/Down/Follow

**Fader 2**

- 1 - Enable/Disable Quickstep
- 2 -
- 3 -
- 4 -
- 5 -
- 6 - Delete
- 7 - More Softkeys → *Fader*
- 8 - DMX In

**Attributes**

- 1 - Positive/Negative
- 2 - Alternate
- 3 - Reverse
- 4 - Bounce
- 5 - Build
- 6 - Random
- 7 - Random Rate
- 8 - Return → *Effect*

**Park**

- 1 -
- 2 - A
- 3 - B
- 4 - Previous Page
- 5 - Next Page
- 6 -
- 7 -
- 8 -

**Setup**

- 1 - Show Name
- 2 - Set Clock
- 3 -
- 4 -
- 5 -
- 6 -
- 7 -
- 8 -

**System Settings**

- 1 - Purge Flexi
- 2 -
- 3 -
- 4 -
- 5 -
- 6 -
- 7 -
- 8 - Return → *Setup*

**Designer's Layout**

- 1 - Sheet/Console Sliders
- 2 -
- 3 -
- 4 -
- 5 -
- 6 -
- 7 -
- 8 - Return → *Settings*

**I/O Configuration**

- 1 - DMX512 Port
- 2 - DMX512 Mode
- 3 - DMX512 Start
- 4 - DMX512 Speed
- 5 -
- 6 -
- 7 -
- 8 - Return → *Setup*

**Disk**

- 1 -
- 2 -
- 3 -
- 4 -
- 5 -
- 6 -
- 7 -
- 8 - Return → *Setup*

**Clear Functions**

- 1 - Reset System
- 2 -
- 3 -
- 4 -
- 5 -
- 6 -
- 7 -
- 8 - Return → *Setup*

**Print Functions**

- 1 - Stop Printer
- 2 - Pause Printer
- 3 -
- 4 -
- 5 -
- 6 -
- 7 -
- 8 - Return → *Setup*

**Options**

- 1 - Disable MIDI
- 2 -
- 3 -
- 4 -
- 5 -
- 6 -
- 7 -
- 8 - Return → *Setup*

**Designer's Editing**

- 1 - Select Region
- 2 - Insert/Replace
- 3 - Delete Entry
- 4 -
- 5 -
- 6 - Clear Region
- 7 - More Softkeys → *Des 2*
- 8 - Return → *Setup*

**Designer's Editing 2**

- 1 - On Sub-Bump
- 2 - Off Sub-Bump
- 3 -
- 4 -
- 5 - Copy Region
- 6 -
- 7 - More Softkeys → *Des*
- 8 -

**Macro Editing**

- 1 - Select Macro
- 2 - Insert/Replace
- 3 - Delete Entry
- 4 -
- 5 -
- 6 - Delete Macro
- 7 - More Softkeys → *Macro 2*
- 8 - Return → *Setup*

**Macro Editing 2**

- 1 - On Sub-Bump
- 2 - Off Sub-Bump
- 3 -
- 4 -
- 5 - Copy Macro
- 6 -
- 7 - More Softkeys → *Macro*
- 8 -

**ETCLink Functions**

- 1 - Enable/Disable ETCLink
- 2 - A
- 3 - B
- 4 -
- 5 -
- 6 - Unset Dimmer
- 7 - Set Dimmer
- 8 - Return → *Setup*

**Dimmer Status**

- 1 -
- 2 -
- 3 -
- 4 - System Status
- 5 - Select Dimmer
- 6 - Rack Status
- 7 -
- 8 - Return → *ETCLink*

**Channel Attributes**

- 1 - Independent
- 2 - Flip
- 3 - Label
- 4 - Previous Page
- 5 - Next Page
- 6 -
- 7 -
- 8 - Return → *Setup*

**SMPT E**

- 1 - Internal Clock
- 2 - Clock Enable/Disable
- 3 - Manual Mode
- 4 - Pause Mode
- 5 - Step
- 6 - Learn Mode
- 7 - More Softkeys→*SMPT E 2*
- 8 - Return → *Setup*

**Real Time Programs**

- 1 - Select Program
- 2 - Time
- 3 - Days of Week
- 4 - Macro
- 5 - Label
- 6 - Delete Program
- 7 - More Softkeys→*RTC 2*
- 8 - Return → *Setup*

**System Status**

- 1 - Multiplex
- 2 - Play Backup
- 3 - Record Backup
- 4 -
- 5 - Dimmer Status
- 6 - Rack Status
- 7 -
- 8 - Return → *ETCLink*

**Load Management**

- 1 - Print Screen
- 2 -
- 3 -
- 4 - Load Check
- 5 - Record Loads
- 6 - Clear Loads
- 7 - Cancel
- 8 - Return → *ETCLink*

**Rack Status**

- 1 -
- 2 -
- 3 -
- 4 - System Status
- 5 - Dimmer Status
- 6 - Select Rack
- 7 -
- 8 - Return → *ETCLink*

**SMPT E 2**

- 1 - Select Event
- 2 - SMPT E Time
- 3 - Cue
- 4 - Rate
- 5 - Bump
- 6 - Macro
- 7 - More Softkeys→*SMPT E 3*
- 8 - Reset Loop

**Real Time Programs 2**

- 1 - Insert Program
- 2 - Copy Program
- 3 - Move Program
- 4 - Previous Page
- 5 - Next Page
- 6 -
- 7 - More Softkeys→*RTC*
- 8 - Sort

**SMPT E 3**

- 1 - Insert Event
- 2 - Copy Event
- 3 - Move Event
- 4 - Previous Page
- 5 - Next Page
- 6 - Delete Event
- 7 - More Softkeys→*SMPT E*
- 8 - Sort

# index

## A

- A 40, 314
- About 38
  - About Dimmer w/ETCLink 39
  - Channel 53
  - Dimmer 38
  - Show 4
- Accessories 203
  - Alphanumeric keyboard 212
  - Designer's Worksheet 207
  - ETCLink 213
  - Infrared Remote Focus Unit 205
  - Remote Focus Unit 204
  - SMPTE 244
- Add channel 95
- Allfade 56, 314, 319
  - Subroutine step 160
- Alphanumeric keyboard 212, 282
  - Installing 282
  - Keyboard type 282
  - Pinout 282
- Alphanumeric keys 314
- Alternate 314
- And 314
- Arrow keys 6
- Asterisk 11, 12, 13
- At 314
- Attribute 314
- Attributes
  - Channel Attributes display 45

## B

- B 40, 315
- Back 103, 315
- Back panel 272
- Backup looks 221
  - Playing 226
  - Recording 225
- Blackout 263, 315
- Blackout cue 86
- Blackout key
  - Disable 21
  - Enable 21
- Blind 61
  - Cue List 76
  - Display 8, 315
  - Multipart cues 94
  - Record cue 62

- Boldface 3
- Bounce (effect) 315
- Bounce (subroutine) 161, 315
- Brackets 3
- Build 315
- Bump (SMPTE) 316
- Bump buttons 128
- Bump buttons, enable/disable 25
- Bump Status 316

## C

- Calibrate 316
- Cancel 316
- Captured channels 36, 44, 316
- CD80 41
- Changing pages 6
- Channel 316
  - Capture all active 50
  - Captured 44
  - Captured in Patch 36
  - Channel Attributes display 45
  - Channel Check 52
  - Channel levels 43
  - Color 6
  - Flash 50, 324
  - Flipped 47
  - Full 50
  - Groups 107–119
  - Independent 46
  - Label 48
  - Levels 50
  - Match to submasters 23
  - Modes 44
  - Moving 44
  - Park 266
  - Print channel attributes 191
  - Recorded 44
  - Selected 44
  - Selecting channels 49
  - Setting number 16
  - Sneak 51
  - Specifications 310
  - System settings 16
  - Tracked 44
  - Update cue 71, 72
  - Wheel 50
- Channel attributes
  - Clear all 200
- Channel mode 129, 345
- Check
  - Channel check 52
  - Cue check 106
  - Dimmer check 37
  - Dimmer loads 217

- Circuit board
  - Main Processor Revision 0 274
  - Node Revision A 275, 297
- Clear 195, 316
  - Channel Attributes 200
  - Clear (fader) 317
  - Clear (keypad) 316
  - Clear Functions menu 196
  - Clear Loads 317
  - Cues 197
  - Designer's Worksheet 199
  - Fader 99
  - Functions 196
  - Groups 117, 197
  - Loads 219
  - Macros 173, 199, 320
  - Patch 200
  - Real Time Programs 201
  - Regions 199, 211, 317
  - Reset system 202
  - Show 197
  - Show and Patch 198
  - SMPTE events 201, 251
  - Submasters 141, 198
- Clock 24, 26
- Clock Disable 317
- Clock Enable 317
- Colors
  - Channel 6
  - LEDs 127
  - Submasters 76, 142
- Connectors
  - Alphanumeric keyboard 282
  - Dimmer 278
  - Infrared Remote Focus Unit 301
  - Monitor 300
  - Printer 283
  - RFU 288
- Console Sliders 20
- Copy
  - Copy Event 317
  - Copy Macro 317
  - Copy Region 318
  - Cue or group to sub 140
  - Cues 74
  - Group 117
  - Macro 174
  - Region 210
  - SMPTE events 253
  - Submaster to other page 138
  - Submasters 139, 140
- Copy Program 318
- Creating cues 58

- Crossfade 56, 318, 319
  - Subroutine step 160
- Cue 55, 318
  - Allfade 56
  - As groups 118
  - Back 103
  - Blackout cue 86
  - Blind 61
  - Clear all 197
  - Convert to multipart 93
  - Copy 74
  - Copy to sub 140
  - Create loop sequence 67
  - Creating 58
  - Crossfade 56
  - Cue check 106
  - Cue List 76
  - Cue steps (subroutine) 319
  - Delete 74
  - Delete part 94
  - Effect 56, 158
  - Follow 66
  - Go 102
  - Go to 103
  - Hold 102
  - Inserting 75
  - Label 69, 212
  - Link to macro 27
  - Load to sub 140
  - Modify 82
  - Modify attributes 70
  - Modify live 70
  - Modifying channels 70
  - Multipart 91, 95, 333
  - Naming 212
  - Parked cue 268
  - Playing back 97
  - Print 185
  - Print cue list 188
  - Quickstep 106
  - Record 57, 63, 64, 65
  - Record as effect 158
  - Record w/default time 60
  - Record, Blind 62
  - Select cue 98, 102
  - SMPTE display 318
  - Solo 68
  - Specifications 311
  - Split fade time 64
  - Stage 59
  - Subroutine 56
  - Subroutine steps 160
  - Type 56
  - Update channels 71, 72
  - Use as group 118
  - Viewing 58
- Cue List 77, 100, 318, 319
- D**
- Date 26
- Days of week 319, 320
- Decimal point 319
- Default
  - Channel/Submaster link 23
  - Fade Time 17
  - Fader Clear Time 18
  - Level 18
  - Sneak Time 19
- Delete 319
  - Channel 95
  - Cues 74, 319
  - Delete Macro 320
  - Delete Step 321
  - Effect steps 321
  - Entry 320
  - Event 320
  - Group 117, 320
  - Macro 173
  - Part of multipart cue 94, 320
  - Region 211
  - SMPTE events 251
  - Submaster 141, 321
- Designer's Worksheet 207
  - Clear 199
  - Clear Region 211
  - Copy Region 210
  - DIP switch settings 287
  - Installation 284
  - Programming regions 208
  - Setting options 20
- Digitizer 20, 207
- Dimmer 321
  - About Dimmer 38
  - About Dimmer w/ETCLink 39
  - Check loads 217
  - Clear loads 219
  - Dimmer check 37
  - Dimmer Status 321
  - Dimmer Status display 223
  - DMX512 speed 280
  - DMX512 starting number 279
  - Error messages 227
  - Installation 278
  - Label 34
  - Loads 215
  - Monitor loads 215
  - Monitoring 213
  - Multiplex 40, 279
  - Park dimmer 264
- Patch 29, 31
- Pinout 278
- Ports 279
- Profile 35
- Rack status 222
- Record loads 216
- Set 224
- Setting 16
- Strand CD80 rack 41
- System settings 16
- Unset 224
- Dimming, Sensor 213
- DIP switch settings 273
  - Designer's Worksheet 287
  - ETCNet 298
  - Remote Video Interface 297, 298
- DIP switches 273
- Disable
  - Blackout key 21
  - Disable ETCLink 321
  - ETCLink messages 228
  - MIDI 321
  - MIDI Show Control 235
  - Record Lockout 24
- Diskette 177
  - Directory 178
  - Drive specifications 311
  - Erase diskette 179
  - Error messages 305
  - Format 179
  - Management 178
  - Read all 181
  - Read system settings 181
  - Record show 180
- Display
  - Blind 8, 61
  - Channel Attributes 45
  - Clear Functions 196
  - Cue List 76
  - Dimmer Status 223
  - Dimmer System Status 221
  - Diskette Functions 177
  - Fader 9
  - Group List 121
  - Groups 110
  - Input/Output Configuration 279
  - Load Errors 220
  - Macro 168
  - Park 14, 263, 270
  - Patch 13
  - Print Functions 184
  - Rack status 222
  - Setup 341

- SMPTE Edit 247
- Specifications 310
- Stage 7, 59
- System Settings 15
- DMX In 242, 322
  - Enable 243
  - Fader display 242
  - Softkey 242
  - Starting channel 242
- DMX512 279, 280
  - Connectors 278
  - Mode 322
  - Pinout 278
  - Ports 279, 322
  - Speed 280, 322
  - Starting number 279, 322
- DMX512 Input 242
- Down 347
- Down Arrow 322
- Dwell 146, 327
  - Dwell time 146
  - Effect 153
  - Submaster 131, 132

**E**

Edit

- Clear submasters 141
- Copy cues 74
- Copy groups 117
- Copy submaster 139, 140
- Cue in Blind 62
- Cue List 76
- Delete cue 74
- Effects 155–157
- Events 247
- Load submaster 140
- Macro 173
- Range of effect steps 149
- Range of groups 77
- Range of submasters 143
- SMPTE programs 251
- Submasters 136
- Update cue 72
- Effect 56, 145, 323
  - 1-to-1 channel assignment 149
- Alternate 150
- Attributes 150
- Bounce 150
- Build 150
- Configuring 150
- Creating steps 147
- Cue 56, 158, 323

- Dwell time 146
- Fade time 152
- High and low levels 146
- In time 146
- Insert step 155
- Modify 155
- Negative 150
- Out time 146
- Positive 150
- Random 150
- Random Rate 154
- Record as cue 158
- Reverse 150
- Specifications 311
- Step element 149
- Step time 146
- Steps 146, 146–148, 156, 343
  - Submaster 124, 158, 323
- Electronic Theatre Controls, Inc. 2
- Element 149
- Enable
  - Blackout key 21
  - DMX In 243
  - ETCLink 214, 323
  - ETCLink messages 214
  - Record Lockout 24
  - Sliders 20
- Enter 323
- Enter Macro 323
- Error messages 227, 307
- ETC MIDI 230
  - Configuring 231
  - Message format 231, 232
- ETCLink 213, 221
  - About Dimmer 39
  - Advisory messages 227, 307
  - Backup looks 225
  - Check Loads 217
  - Clear Loads 219
  - Enable 214, 323
  - Error messages 227
  - Fatal messages 227, 307
  - Load errors 220
  - Record Loads 216
  - Secondary messages 308
  - Set dimmer 224
  - Unset dimmer 224
- ETCLink Functions 213, 214, 228
- ETCNet 292–300
- Events, Edit 247
- Except 134, 324

**F**

Fade
 

- Fade Type 347
- Multipart 96
- Rate 105
- Split 64
- Times 63, 161
- Type 56

Fade time, effect 152

Fader
 

- Back 103, 315
- Clear 99, 317
- Default Clear Time 18
- Display 9, 324
- Go 102, 325
- Hold 102, 327
- Manual 104
- Rate 336
- Specifications 309
- Status display 324
- Timed 99

Flash 50, 324

Flexichannel 11, 22, 175, 325
 

- Purge Flexi 11, 49
- Selecting channels 49
- Update 11

Flip 45, 47, 325

Follow 66, 67, 325, 347

Follow time 161

Format diskette 179

Full 50, 325

**G**

Go 102, 325

Grandmaster 23

Group 107, 326
 

- Blind 111
- Clear all 197
- Copy 117
- Copy to sub 140
- Create 108
- Create w/Solo 109
- Delete 117
- Displaying 110
- Group Editing mode 111, 326
- Group List 121, 326
- Group mode 111, 326
- Label 116
- Load to sub 140
- Modify cue or sub 119
- Modifying 112
- Naming 212
- Only 120
- Park 268
- Print 186

- Print group list 188
- Range edit in Group List 77
- Specifications 311
- Update 114
- Use cue or sub 118

## H

- Help 3, 326
- Hide Labels 34, 341
- High levels 146
- Highest level 3
- Hold 102, 326
- Hold-for-Go (subroutine) 161, 327
- Home position 124

## I

- In 146
- In time 146
- In/Dwell/Out 327
- Independent 45, 46, 327
- Independent channels 327
- Infrared Remote Focus Unit (IR-FU) 205
  - Enabling 301
  - Installing 301
  - Pinout 301
- Inhibitive submaster 124, 135, 327
- Input/Output configuration 279
- Insert
  - Cue 75
  - Insert Event 328
  - Insert Step 328
  - Inserting cues 84
  - Inserting SMPTE events 252
- Insert Program 328
- Insert/Replace 328, 338
- Installation 271
  - Alphanumeric keyboard 282
  - Designer's Worksheet 284
  - Dimmers 278
  - ETCNet 292
  - Infrared Remote Focus Unit 301
  - MIDI 289
  - Printer 283
  - Remote Interface 294
  - Remote macro 302
  - Remote monitors 300
  - Remote Video Interface 296
  - RFU 288
  - SMPTE 291
- Internal Clock 328
- IRFU 205
- Italic 3

## J

- Jumper settings 273, 275
  - MIDI Out/Thru 290
- Jumpers 273
- Jump-to-cue 161, 329

## K

- Keypad Numbers 329
- Keys
  - About 38, 53
  - Back 103
  - Clear 99
  - Except 49, 324
  - Follow 66
  - Full 50
  - Go 102
  - Group 118
  - Hold 102
  - Label 116, 212
  - Learn 166
  - Level 50
  - Link 66
  - Only 120
  - Rate 105
  - Solo 68, 109
  - Solo Bump 129
  - Sub Mode 129
  - Sub Page 126
  - Type 125

## L

- Label 45, 329
  - Channel 48
  - Cues 69
  - Dimmer 34
  - Group 116
  - Submasters 139
- Last Page 329
- Learn 329
  - Learn (Macro) 329
  - Learn mode (SMPTE) 329
  - Macro 166
  - SMPTE 249
- LEDs
  - Faders 99
  - Submaster 127
- Left Arrow 330
- Level 50, 161, 330
  - Default Level 18
- Level wheel 50, 330
- Lighting Playback Controller 260
- Link 66, 67, 330
  - Macro to macro 170

## List

- Cue List 76, 100
- Group List 121
- Submaster List 142, 143
- Load 330
  - Cue or group to sub 140
  - Effects 158
  - Errors 220
  - Load Check 218, 330
- Loop 161
- Loop (subroutine) 331
- Low levels 146
- Low/High Levels 331
- LPC 260

## M

- M\* 331
- M1-M5 331
- Macro 165, 331
  - Cancel 172
  - Clear 173
  - Clear all 199
  - Copy 174
  - Creating 166–167
  - Display mode 168
  - Edit 173
  - Learn 166, 329
  - Link to cue 67
  - Link to macro 170
  - M\* 331
  - M1-M5 331
  - Macro Wait 169, 209, 331
  - Macro wait 331
  - Modify 173
  - Play 172
  - Print 190
  - Remote 303
  - Remote macros 260
  - Remote Trigger 261
  - Samples 175
  - SMPTE 331
  - Specifications 311
  - Submasters in 171
- Manual 332
  - Manual Mode 332
  - Override cue 104
  - Override submaster fade 138
- Master
  - Set type 23
- Memory 4

- Menu
    - Clear Functions 196
    - Designer's Worksheet Setup 20
    - Diskette Functions 177
    - ETCLink Functions 213, 214, 228
    - Print Functions 184
    - Setup 341
    - System settings 15
  - MIDI 230
    - Configuring ETC MIDI 231
    - ETC MIDI 230
    - ETC MIDI message formats 231, 232
    - Installation 289
    - Interfacing with 289
    - Message definitions 233
    - Out/Thru settings 290
    - Pinout 290
  - MIDI Show Control 230, 234
    - Configuring 235
    - Disable 235
    - Fire 235
    - Go 235
    - Resume 235
    - Stop 235
  - Minus 332
  - Modify
    - Channel 95
    - Cue attributes 70
    - Cues 70
    - Effect 155
    - Groups 112
      - With Group 114
    - Macro 173
    - Multipart fade time 96
    - Multipart wait time 96
    - Submaster 136
  - Modifying
    - Submasters 136
  - Monitor
    - Connectors 300
    - Pinout 300
    - Remote video 300
  - Move Event 332
  - Move Program 333
  - Moving channels 44, 333
  - Moving lights 120
  - Moving SMPTE events 254
  - MSC 230, 234
  - Multipart cue 91, 333
    - Converting regular cue to 93
    - Creating 92
    - Definition 333
    - Delete part 94
    - Editing channels 94
    - Modify channels 95
    - Wait time 94
  - Multiplex 221, 280, 333
  - Multiplex dimming technology 40
  - Multiplexed dimmers 40, 279
  - Multiplexer 40
  - Musical Instrument Digital Interface 230
- N**
- Naming
    - Channels 48
    - Cues 69, 212
    - Groups 212
    - Shows 27
    - Submasters 212
  - Next Page 6
- O**
- Off Sub-Bump 171, 333
  - On Sub-Bump 171, 334
  - One-to-one patch 30
  - Only 120, 334
  - Optional equipment
    - Alphanumeric keyboard 282
    - Designer's Worksheet 284
    - Infrared Remote Focus Unit 205, 301
    - Remote Focus Unit 288
  - Out 146, 327
  - Out time 146
  - Output configuration 279
  - Output level conventions 3
- P**
- Page 6, 126, 334
    - Submasters 126, 133
  - Park 14, 263, 334
    - Channel 266
    - Cue 268
    - Dimmer 264
    - Display 14, 270
    - Group 268
    - Submaster 268
    - Unpark channel 267
    - Unpark cue 268
    - Unpark dimmer 265
    - Unpark group 268
    - Unpark submaster 268
  - Parts 91, 333, 334
  - Patch 29, 334
    - Captured channels 36
    - Clear 198, 200
    - Custom 30
    - Dimmers 31
    - Display 13, 334
    - Multiplex 40
    - Print 191
    - Proportional patch 32
    - Reset 200
  - Pause Mode 335
  - Pause Printer 335
  - Pile-on submaster 124, 335
  - Pinout
    - Alphanumeric keyboard 282
    - Dimmer 278
    - MIDI 290
    - Monitor 300
    - Printer 283
    - Remote macros 303
    - RFU 288
    - SMPTE 291
  - Play Backup 335
  - Playback
    - Cues 97
    - Display 100
    - Macro 172
    - Monitor 318, 324
    - SMPTE events 245, 257
    - Specifications 310
  - Plus 335
  - Positive/Negative 335
  - Previous 335
  - Previous Page 6, 335
  - Print 183
    - Cancel printer 184
    - Channel Attributes 191
    - Cue list 188
    - Cues 185
    - Group list 188
    - Groups 186
    - Load Errors 220
    - Macro 190
    - Options 184
    - Patch 191
    - Pause printer 184
    - Print Screen 335
    - Printer 283
    - Real Time Programs 192
    - SMPTE 192
    - Stage display 184
    - Submaster list 189
    - Submasters 187
    - Tracksheet 193

- Profile 336
  - Assign to dimmer 35
  - Dimmer 35
  - Specifications 311
- Programming regions 208
- Proportional patching 32
- Purge Flexi 11, 49, 336

## Q

- Quickstep 106, 336

## R

- Rack Status 222, 336
- Random 336
- Random Rate 154, 336
- Range edit
  - Effect steps 149
  - Group List 77
  - SMPTE events 255
  - Submaster List 143
- Rate 337
  - Override 105
  - Random rate 154
  - Rate (fader) 336
  - Rate (SMPTE) 337
  - Submaster 133, 138
  - Update 73
  - Wheel 337
- Real Time Clock 238
- Real Time Programs 238
  - Clear all 201
  - Print 192
- Record 337
  - Cue 57, 62, 63, 65
  - Cue w/split fade time 64
  - Effect as cue 158
  - Follow 66
  - Group minus sub 109
  - Groups 108
  - Loads 216
  - Record Backup 337
  - Record Lockout 24
  - Recorded channels 44
  - Show to diskette 180
  - Solo 68
  - Sub minus sub 134
  - Submasters 128, 130
  - Track 57
- Record Loads 337
- Record Lockout 338
- Recorded channels 338
- Region
  - Clear 211
  - Clear all 199
  - Copy 210
  - Programming 208

- Release 338
- Remote Focus Unit 204
- Remote Interfaces 292–300
- Remote macros 260, 303
  - Pinout 303
- Remote Trigger 261
- Remote video 300
- Remote Video Interface 296
  - DIP switch settings 297, 298
- Replace/Insert 338
- Reset Loop 250, 338
- Reset patch 200
- Reset System 202, 338
- Return 338
- Reverse 339
- RFU 204, 288
  - Connector 288
  - Installation 288
  - Pinout 288
- Right Arrow 339

## S

- Select Cue 98, 339
- Select Dimmer 339
- Select Event 339
- Select Fader 339
- Select Group 339
- Select Macro 339
- Select Program 340
- Select Rack 340
- Select Region 340
- Selected channels 44, 340
- Selecting channels 49
- Sensor 40, 213, 215
  - Backup looks 225
  - System status 221
- Set
  - Channel levels 43, 50, 52
  - Clock 26, 340
  - Date 26
  - Default fade time 17
  - Default fader clear time 18
  - Default level 18
  - Default Sneak Time 19
  - Dimmer 224
  - Dimmer levels 37
  - Master type 23
  - Record Lockout 338
  - Set Dimmer 340
  - Show name 27
  - System settings 15
  - Time 26
  - Time format 24
- Setup 341
- Sheet Sliders 20

- Show
  - Clear 197, 198
  - Name 27, 341
- Show Labels 34, 341
- Show/Suppress Labels 34
- Slider
  - Master 23
- Sliders 20
- SMPTE 244
  - Clear all 201
  - Copying events 253
  - Creating programs 246
  - Delete events 251
  - Editing events 255
  - Editing programs 251
  - Enabling port 245, 257
  - Frame rate 245
  - Insert events 252
  - Installation 291
  - Interfacing with 291
  - Internal clock 317
  - Learn mode 249
  - Moving events 254
  - Pinout 291
  - Playing events
    - External source 257
    - Internal clock 258
    - Manual 259
  - Print 192
  - Range editing 255
  - Reset Loop 250
  - SMPTE Time 341
  - Viewing events 258
- Sneak 51, 342
  - Default time 19
- Softkeys 349
  - Flash 50
  - Quickstep 106
  - Select Group 111
  - Unload sub 141
  - Update 71, 72, 114, 137
- Solo 68, 342
- Solo Bump 129, 342
- Solo record 109
- Sort 342
- Specifications 309–312
- Split fade 64
- Stage 59, 342
- Stage display 7
  - Print 184
- Step 146, 342
  - Creating 147
  - Delete 156
  - Editing characteristics 156
  - Effect 343

- Element 149
  - Insert 155
  - SMPTE 342
  - Step Time 343
  - Subroutine 160, 343
  - Time 146
  - Steps 146
  - Stop Printer 343
  - Strand CD80 41
  - Style 161, 344
  - Style steps (subroutine) 344
  - Sub 344
  - Sub Grandmaster 23
  - Sub List 344
  - Sub Mode 129, 345
  - Submaster 123, 344
    - Bump Button Mode 129
    - Bump buttons 130, 344
    - Changing shows 126
    - Changing type 125
    - Channel mode 129
    - Clear 141
    - Clear all 198
    - Copy 139, 140
    - Copy cue or group 140
    - Copy to other page 138
    - Default match to channels 23
    - Dwell times 130
      - Hold 132
      - Manual 132, 332
    - Effect 124, 158
    - Except 134
    - Fade times 130, 131, 138
    - Home position 124
    - In macros 171
    - Inhibitive 124, 135, 327
    - Label 139
    - Labels 139
    - LEDs 126, 127, 135
    - List 138, 142
    - Live edit 136
    - Load cue or group 140
    - Load effect 158
    - Manual control 138
    - Manual fade 138
    - Manual time 132
    - Modifying 136
    - Naming 212
    - Override fade time 138
    - Pages 126, 133
    - Park 268
    - Pile-on 124
    - Print 187
    - Print submaster list 189
    - Range edit in Submaster List 143
    - Rate 133, 138, 337
    - Record 130
    - Recording 133
    - Sliders 138, 158
    - Solo mode 129
    - Specifications 310
    - Submaster display edit 136
    - Submaster List 142, 143
    - Submaster mode 129
    - Time ??-138
    - Types 124
    - Update 137
    - Use as group 118
  - Submaster mode 345
  - Subroutine 56, 159, 345
    - Allfade cue steps 160, 319
    - Attributes
      - Follow time 161
      - Level 161
    - Bounce style steps 161, 315
    - Creating 162
    - Crossfade cue steps 160, 319
    - Cue steps 319
    - Deleting step 164
    - Down 347
    - Editing 164
    - Follow 347
    - Hold for go style steps 161, 329
    - Inserting step 164
    - Jump to cue style steps 161, 329
    - Level 347
    - Loop style steps 161, 331
    - Steps 160, 343
    - Style steps 161, 344
    - Type 347
    - Up 347
  - Suppress Labels 345
  - System configuration 279
  - System settings 15
    - Default fade time 17
    - Default Fader Clear Time 18
    - Default level 18
    - Default Sneak Time 19
    - Designer's Worksheet options 20
    - Flexichannel 22
    - Name show 27
    - Number of channels 16
    - Number of dimmers 16
  - Record Lockout 24, 338
  - Set Channels/Subs 1-to-1 23
  - Set date 26
  - Setting Clock 26
  - Time format 24
  - System Status 221, 345
- T**
- Technical Services 2
  - Template 20
  - Text conventions 3
  - Thru 345
  - Time 26, 346
    - Default Sneak 19
    - Effect fade time 152
    - Effect In/Dwell/Out time 146
    - Effect Up/Dwell/Down 152-153
    - Follow time 66
    - Format 24
    - Macro Wait 169
    - Set system 26
    - Submaster 130-133
    - Wait 65
    - Wait time in multipart cue 94
  - Timed fader 99
  - Track 57, 79, 80, 81, 346
  - Tracked channels 44, 346
  - Tracksheet 79, 88
    - Display 12, 346
    - Print 193
  - Troubleshooting 2
  - Type 346
    - Changing sub 125
    - Cue 56
    - Submaster 124
  - Type/Level 347
- U**
- Unload submaster 141
  - Unpark channel 267
  - Unpark dimmer 265
  - Unpatching dimmers 347
  - Unset Dimmer 224, 347
  - Up Arrow 347
  - Up/Down/Follow 347
  - Update 348
    - Cue 71, 72
    - Flexichannel 11, 49
    - Groups 114
    - Rate 73
    - Submasters 137

**V**

Viewing cues 58

**W**

Wait 94

    Multipart 96

Wait time 348

    Record cue 65

Wheel 348

    Level 50