

COLOR  SOURCE

# User Manual

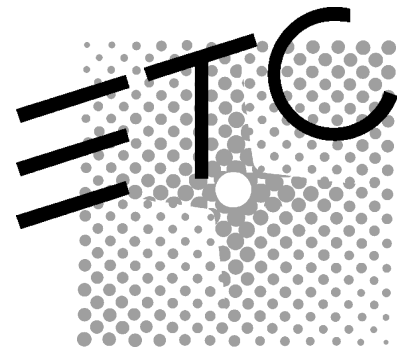

# COLOR SOURCE

---

## Color Changer and Power Supply

# User Manual

Software version 1.011

### Contents

Introduction .....	5
The ColorSource System .....	6
Using ColorSource .....	7
ColorSource components .....	8
Color Changer .....	8
Gelstring .....	8
Power Supply .....	9
Cables .....	9
Installing ColorSource .....	10
Mounting the Power Supply .....	12
Installing rack mount brackets on the Power Supply .....	12
Installing pipe mount brackets on the Power Supply .....	13
Replacing a gelstring .....	14
Replacing the mounting plate .....	16
Specifications .....	17
Parts list .....	18
Custom gelstring order form .....	19



# Introduction

The ColorSource system includes a scrolling Color Changer and Power Supply. Its ten-color capacity and DMX512 compatibility makes it economical and versatile, particularly for designers with limited budget and space. The lightweight Color Changer slides easily into the gel frame holder of the light fixture and the compact 12 output Power Supply attaches easily to the truss of the lighting rig or in a 19 inch rack.

This manual gives step-by-step instructions for preparation, setup and operation of the ColorSource Color Changer and ColorSource Power Supply.

The Color Changer is delivered to you with your choice of gelstring and mounting plate installed. If you need to change gelstrings or mounting plates, instructions are included in this manual.

# The ColorSource system

The ColorSource system consists of one or more ColorSource Color Changers and a ColorSource Power Supply which can power and control up to 12 scrolling Color Changers. The DMX512 control signal from the lighting board is connected to the power supply and can continue on to more ColorSource power supplies or other DMX512 controlled devices. The power supply sends both power and control signal on a single cable, eliminating the need for a separate power cable for each color changer.

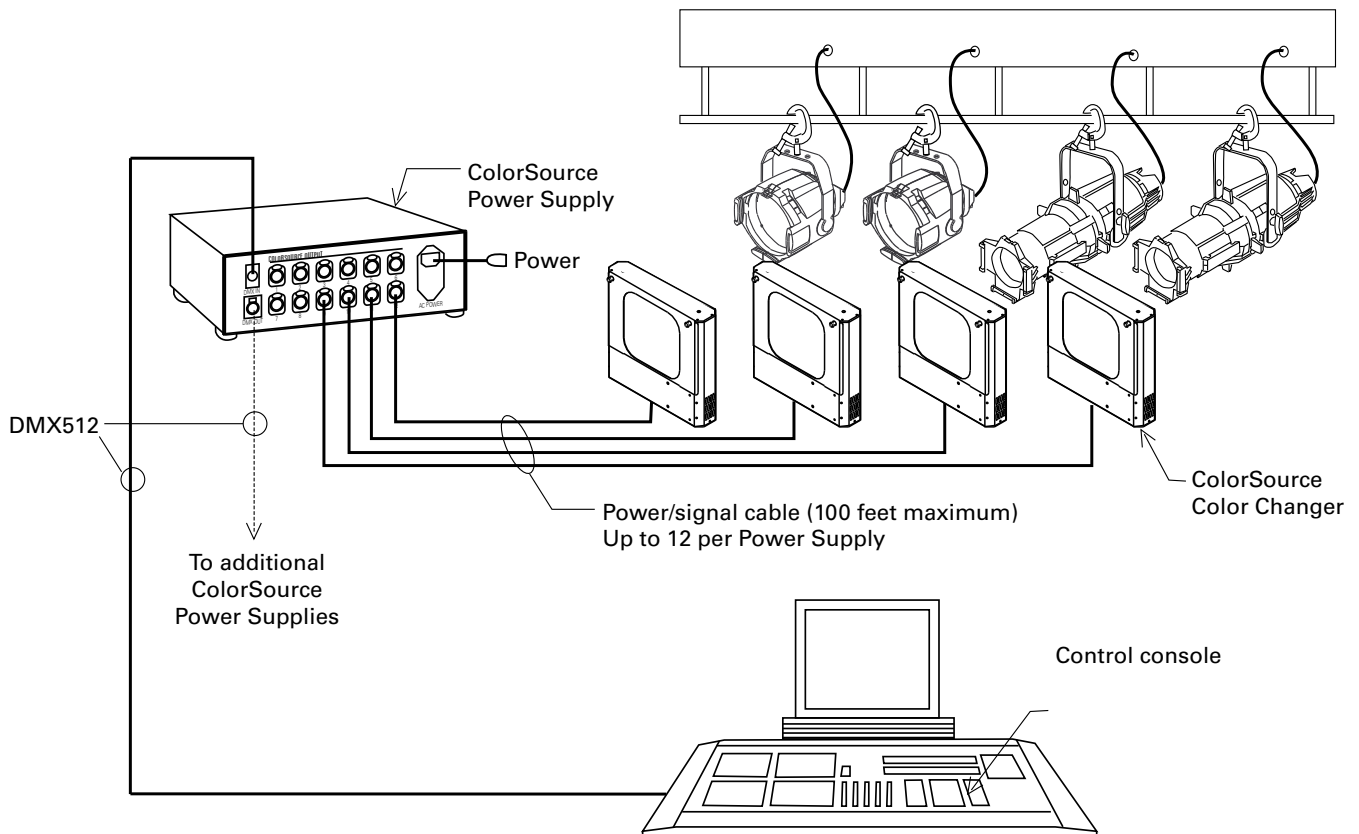

# Using ColorSource

The Color Changer sets its frame position according to the DMX512 level it receives from the control console using the channels set on the Power Supply. The following chart shows the level settings that correspond with each frame position, and the color of that frame, if you are using the standard ColorSource gelstring. If you are using a custom gelstring, of course, the colors are different, but the channels and frames are the same.

<b>Channel level</b>	<b>Frame position</b>	<b>Standard color</b>
0	Frame 1	Clear
11	Frame 2	Antique Rose
22	Frame 3	Chorus Pink
33	Frame 4	Magenta
44	Frame 5	Light Red
55	Frame 6	Deep Amber
66	Frame 7	Mellow Yellow
77	Frame 8	Light Green
88	Frame 9	Aztec Blue
99	Frame 10	Light Purple

If you send a channel level that is between the values shown, you can create split frame effects. For example, if you send a level of 50, the Color Changer positions the gelstring halfway between frame 5 and frame 6 creating a blend of the two colors.

# ColorSource components

## Color Changer

The ColorSource Color Changer holds a ten color gelstring. A signal from the power supply controls the position of the gelstring. Low voltage AC from the Power Supply provides power to the Color Changer. This control signal and the low voltage AC power are both supplied by the single cable connecting the Color Changer to the Power Supply.

A fan in the base of the Color Changer runs whenever the Color Changer is connected to the Power Supply. This protects the gelstring from overheating. The fan is most effective when the Color Changer is oriented with the fan directing air up.

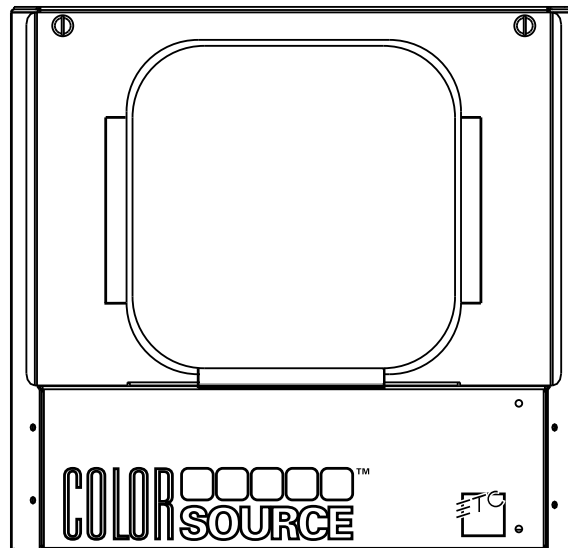

## Gelstring

The gelstring is a series of ten precisely cut colored gel frames, joined together side-by-side to create a sequence of colors. Two additional gels at each end of the gelstring are called the leader and the trailer and are five inches wide to allow for proper attachment to the rollers.

If you need to replace the gelstring in your Color Changer, the ColorSource system's Autoload feature walks you through the simple gelstring loading procedure. See page 15.

*Note: Gelstrings may be ordered from either ETC or ColorExpress by Wybron. See page 19 for an order form*

## Power Supply

The Power Supply converts the DMX512 signal level into a control signal and sends this control signal along with low voltage AC on one cable to power each color changer. The Power Supply features a DMX512 bypass relay to pass the DMX512 signal to the DMX512 output connector in the event of loss of power supply AC power.

The Power Supply features a liquid crystal display (LCD) that lets you select between the Channel display and the Autoload display. When you turn it on, the Power Supply displays a scrolling introduction including the Power Supply software version, then goes to the Channel display.

The Channel display shows the 12 DMX512 channels and the message **DMX OK** or **NO DMX**. This indicates whether or not the Power Supply is connected to a DMX512 source.

Press [Menu] to switch from the Channel display to the Autoload display. The Autoload display walks you through the process of loading a gelstring onto the Color Changer's rollers and testing it.

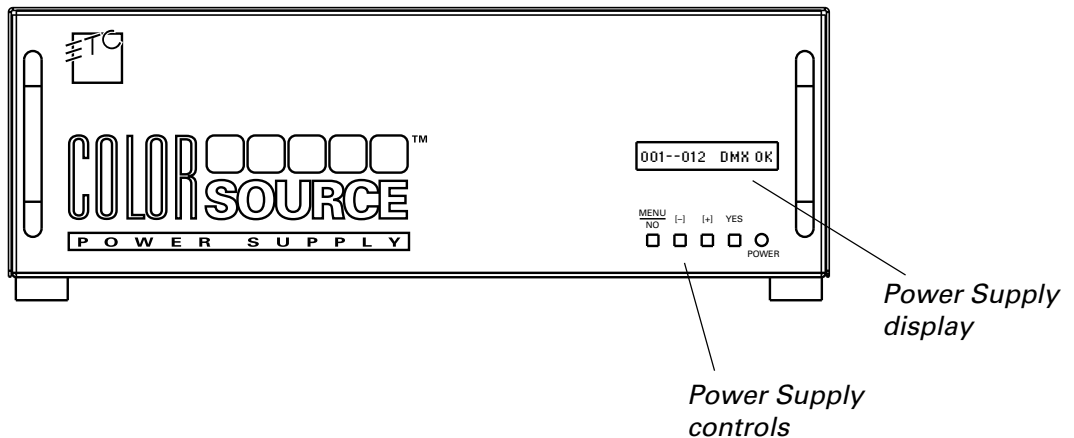

## Cables

A ColorSource cable connects each Color Changer to one of the 12 Power Supply outputs and provides the Color Changer with power and control signal. A DMX512 cable connects the Power Supply to a DMX512 signal source, usually a lighting control console.

# Installing ColorSource

To get your ColorSource system up and running, follow these hookup and checkout procedures.

## 1. Attach the Color Changer to the lamp

Slide the Color Changer's mounting plate into the gel frame holder of your lamp and lock the gel frame retention clip.

If the mounting plate installed on your Color Changer doesn't fit the fixture, you may replace it with a differently sized plate. See page 16 for information on changing mounting plates.

The mounting plate allows you to position the Color Changer with the gelstring rolling either horizontally or vertically. However, ColorSource operates most effectively with the fan blowing air vertically (as hot air naturally rises).

## 2. Attach safety cable

A safety cable is attached to the back and right-hand side of the Color Changer. Run this cable around the pipe or truss from which you hang the light fixture and clip it to itself.

## 3. Connect Color Changers to the Power Supply

Connect the Color Changers to the Power Supply using the supplied 6-pin power/signal cable. The connectors are on the bottom of the Color Changer and the back of the Power Supply.

*Note: Both power and signal are supplied to the Color Changers by the same cable. The Color Changer connected to output connector 1 operates on the first of the 12 DMX512 channels, the color changer connected to output connector 2 operates on the second, and so on. Only one scroller may be connected to each output connector.*

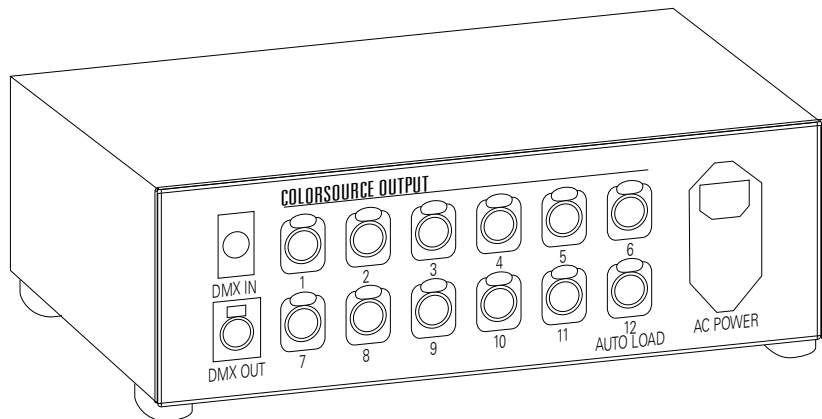

## 4. Connect Power Supply to AC power

Plug the pronged end of the AC power cord into a 115 VAC (50/60Hz) non-dimmed circuit. Plug the other end into the connector labeled **AC Power** on the back of the Power Supply. All connected Color Changers position their gelstrings to frame 1.

*Warning: Do not power the unit from a dimmer. Severe damage will result, and is not covered by product warranty.*

*Note: Avoid line voltages lower than 105 VAC or higher than 125 VAC as the system may not run properly outside of these limits.*

## 6. Connect and set the DMX512 source



001--012 NO DMX

Before you connect the DMX512 source, the Power Supply display reads **NO DMX**. Connect the DMX512 signal source to the DMX512 input connector on the Power Supply using standard DMX512 cable. The display reads **DMX OK** and the Color Changers position their gelstrings according to their respective DMX512 signal levels.

## 7. Set the Power Supply DMX512 channels



001--012 DMX OK

Each Power Supply is assigned a range of 12 DMX512 channels, corresponding to its 12 outputs. The Power Supply's Channel display shows the range of channels. To adjust the range of channels, press [+] or [-] while in the Channel display.

*Hint: Hold down [+] or [-] to scroll through the channels quickly*

*Note: The Power Supply automatically senses the number of dimmers transmitted by the lighting console and won't allow you to set the DMX512 channels outside this range.*

# Mounting the Power Supply

The Power Supply comes with four sturdy rubber feet installed, allowing you to set it on any stable flat surface. If you wish, bracket kits are available from ETC that allow you to hang the Power Supply from a pipe, or install it into a rack. The following instructions explain how to use both kits.

*Note: When you mount the Power Supply, keep in mind that you will need access to both the front and rear panels.*

## Installing rack mount brackets on the Power Supply

To install rack mount brackets on your ColorSource Power Supply, follow these steps.

1. Unplug the power cord from the Power Supply.
2. Place the Power Supply on a flat surface.
3. Position the brackets as shown below.
4. Attach the brackets using the supplied screws.
5. Slide the Power Supply into a 19-inch rack and fasten. Remove rubber feet from Power Supply if necessary and save them.

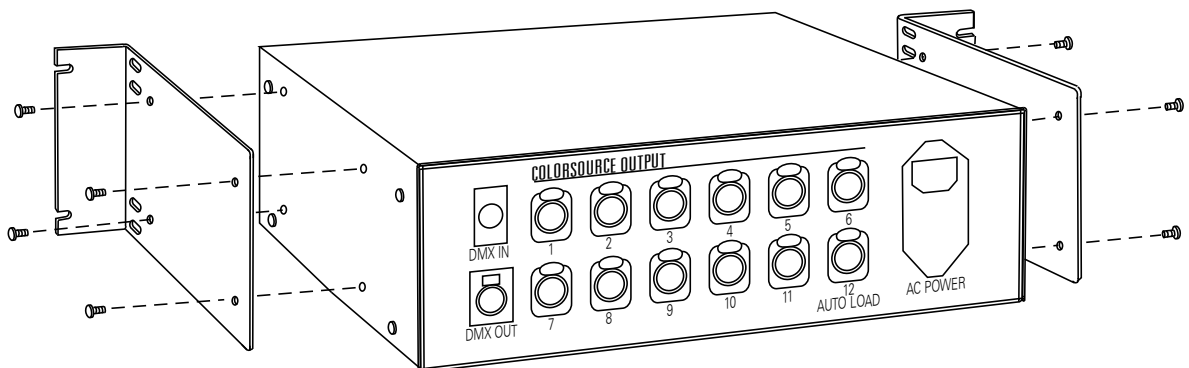

## Installing pipe mount brackets on the Power Supply

To install pipe mount brackets on your ColorSource Power Supply, follow these steps.

1. Unplug the power cord from the Power Supply.
2. Place the Power Supply upside down on a flat surface.
3. Use a Phillips head screwdriver to remove the rubber feet from each of the four corners. Store the feet somewhere safe.
4. Position the brackets as shown below.
5. Attach the brackets using the screws supplied.
6. Mount the Power Supply on the desired pipe using the bolts provided as shown below.
7. Wrap the safety cable around the pipe and clip it to itself.

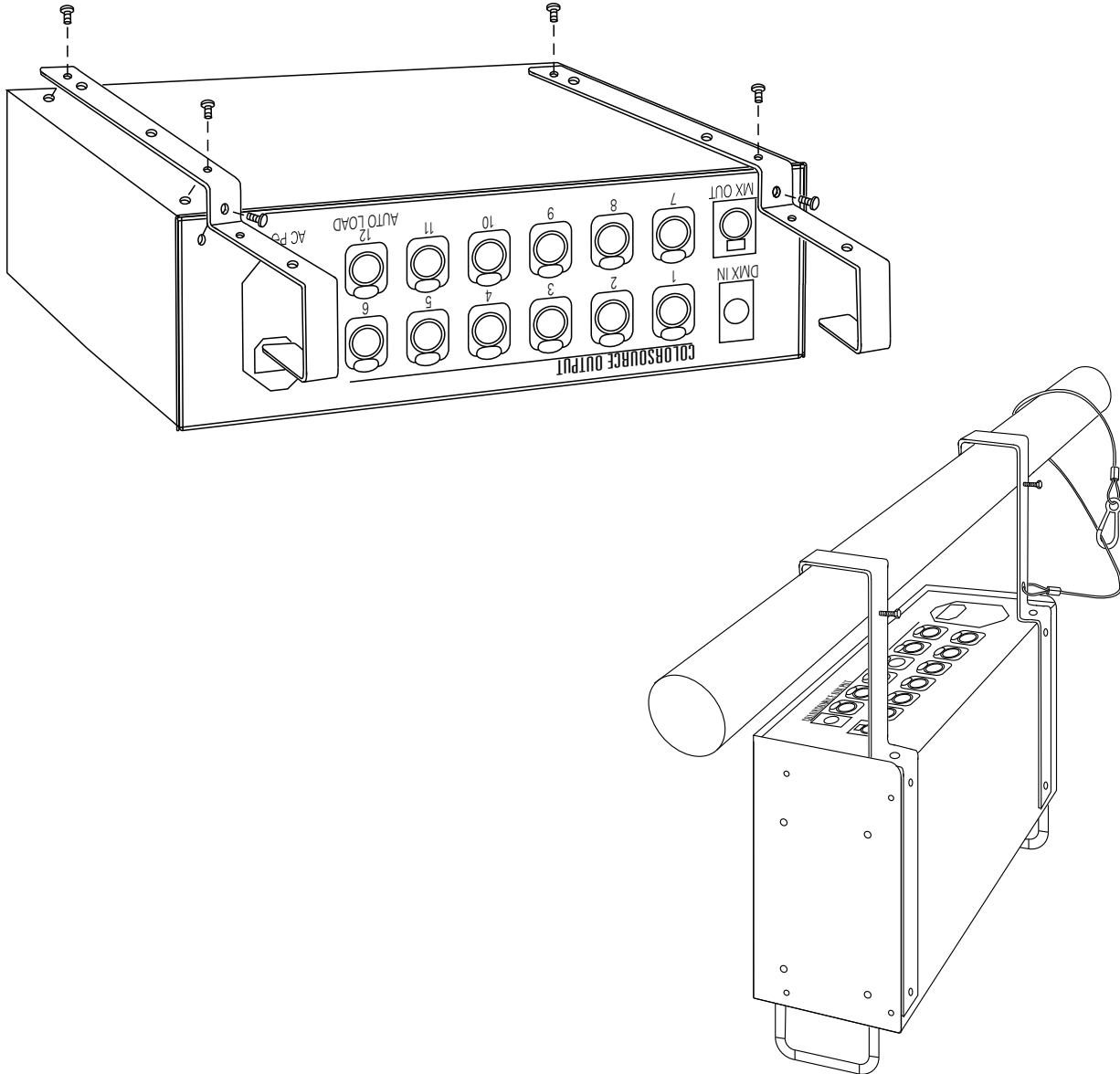

# Replacing a gelstring

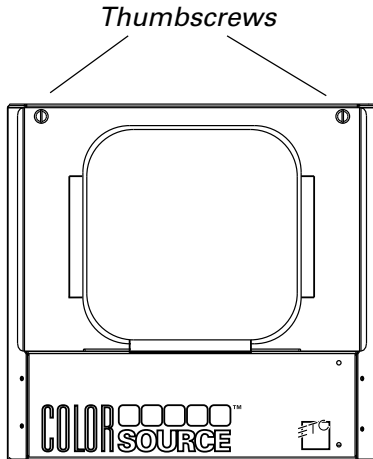

At some point you may find that you need to replace the gelstring in your Color Changer, either because the old one wears out, or because you want a different selection of colors. ColorSource's Autoload procedure makes this easy by walking you through the procedure, step by step.

*Note: The gelstring must be ten frames long for proper operation. If a frame is damaged, do not remove a frame and splice the gelstring. Replace the gelstring.*

*Note: You may install a gelstring with or without a DMX512 source connected to the Power Supply.*

*Warning: Do not force the rollers to turn when turning them by hand. If they do not turn easily, you have not disconnected the DMX512 cable, and should do so immediately.*

To replace a gelstring, follow these steps. Press [Menu/No] at any point in the process to cancel loading.

Left roller  
(trailer/frame 10)

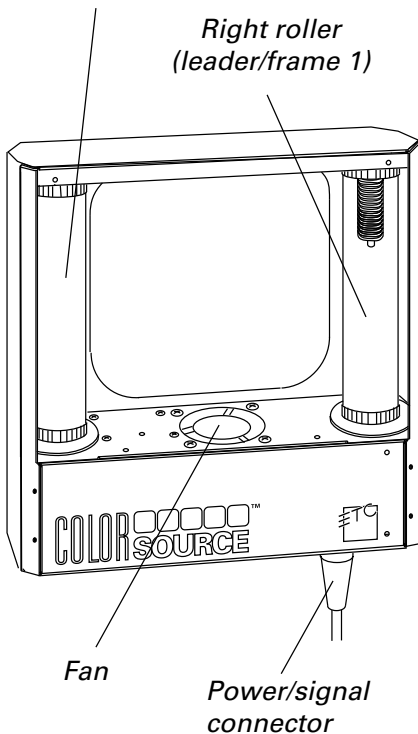

## Remove old gelstring

1. Place the Color Changer on a flat surface with the ColorSource logo facing up. The power/signal cable connector should be facing you, with the cable connecting it to output 12 on the Power Supply (labeled **AUTOLOAD**).
2. Unscrew the two thumbscrews at the top right and left corners of the front panel as shown in first picture at left. Lift the panel by the screws and remove it from the Color Changer.
3. If you are connected to a DMX512 source, set the gelstring to the DMX512 = 100 position.
4. Disconnect power cable from Color Changer.
5. Gently roll the gelstring all the way onto the right roller, exposing the clear trailer taped on the left roller.
6. Untape trailer from left roller. Remove tape from trailer and save it.
7. Roll gelstring into a tube, slowly rolling it off the right roller.
8. When you reach the clear leader, untape it from the roller. Remove the gaffer's tape from leader and save it. If you expect to reuse the old gelstring, reroll it in the opposite direction, so the trailer is on the outside.

## Install new gelstring

*Note: Use gaffer's tape to attach the gelstring to the rollers. Do not use duct tape or masking tape.*

LOAD GELSTRING?

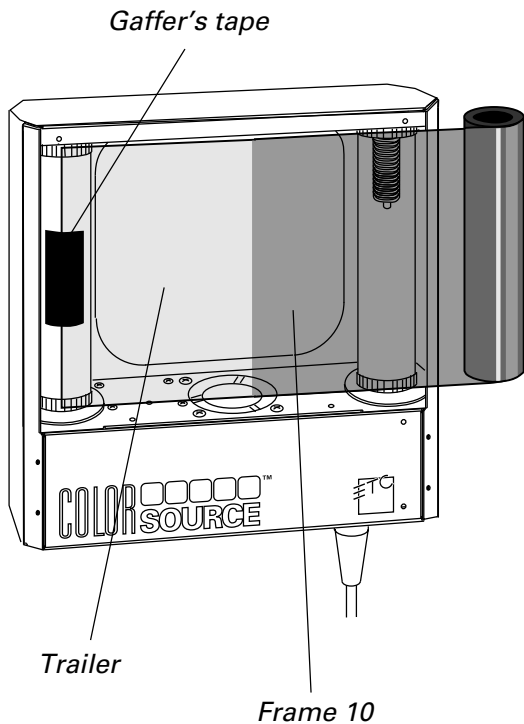

1. Press [Menu] to select **LOAD GELSTRING?** on the display.
  2. Press [Yes]. The display reads **OUTPUT #12 READY?**
  3. Reconnect the power cable to the Color Changer.
  4. Press [Yes]. The rollers reset to frame 10 and the display reads **TAPE TRAILER TO LEFT ROLLER ..... DONE?**
  5. Put a strip of gaffer's tape on the gelstring trailer. Holding the trailer, let the rest of the roll hang off the right side of the Color Changer.
  6. Center the edge of the trailer between the two ends of the left roller as shown to left. Tape the trailer along the top of the roller as shown.
  7. Hold the rolled gelstring loosely in your right hand and press [Yes]. The display reads **LOADING GEL** and the left roller turns to roll the gelstring onto the left roller.
  8. Hold the gelstring lightly to allow it to roll uniformly onto the roller until the display reads **TENSION SPRING 2.5 TURNS TOWARD LEFT ROLLER ..... TAPE LEADER ..... DONE?**
  9. Put a strip of gaffer's tape on the gelstring leader.
  10. Turn the spring roller two and a half turns to the left, then tape the edge of the leader centered along the top of the spring roller. The sticker at the bottom end of the roller has a black line on it to help you judge the number of turns.
  11. Replace the front panel, tightening the two screws gently.
  12. Press [Yes] when done. The display reads **GEL TO ZERO?**
  13. Press [Yes]. The gelstring moves to frame 1. Check for proper color positioning. The display reads **GEL TO FULL?**
  14. Press [Yes]. The gelstring moves to frame 10. Check for proper color positioning. The display reads **LOAD COMPLETED?**
  15. Press [Yes]. The Color Changer returns to its current DMX512 level if it is connected to a DMX512 source, or to frame 1 if it isn't, and the Power Supply returns to the Autoload display.
  16. Press [Yes] to load another gelstring, or press [No] to return to the Channel Display screen.
  17. Replace the front panel and tighten the thumbscrews securely.
- The gelstring is now loaded onto the ColorSource Color Changer. If the gelstring colors did not center properly at the zero and full positions, remove the gelstring (see previous page) and repeat the Autoload process until they center properly.

*Note: Gel material of different thicknesses may cause slight variation in frame positions at zero. This is normal.*

# Replacing the mounting plate

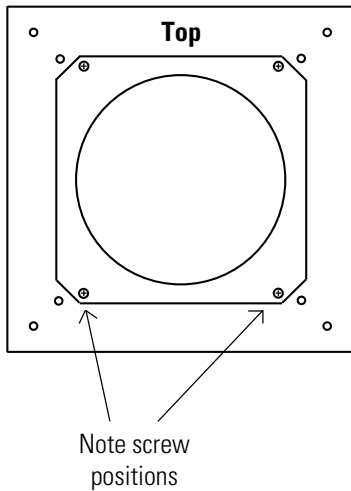

This mounting plate fits spotlights with a 6.25" frame size, including ETC Source Four. Mount the plate in the orientation shown. Note that the screws are closer together in one direction than the other.

The ColorSource Color Changer ships with your choice of available mounting plates installed. Always use the supplied screws as they are treated with an anti-vibration compound to keep them from loosening.

Follow these steps to replace the mounting plate.

1. Place the Color Changer on a flat surface, with the ColorSource logo face down.
2. Unscrew the four screws that hold the current mounting plate on.
3. Place the replacement mounting plate on the Color Changer aligning the screw holes properly. If you are installing the 6.25" mounting plate, see the illustration to left for proper plate orientation.
4. Fasten the four corners of the mounting plate to the Color Changer using the same screws you removed in step 2.

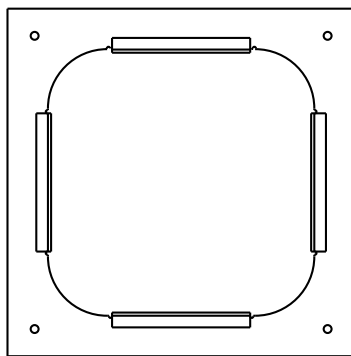

This mounting plate fits spotlights with a 7.5" frame size, including ETC Source FourPAR.

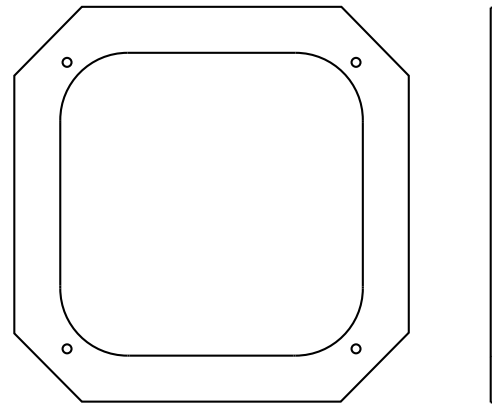

This mounting plate fits spotlights with a 10" frame size.

# Specifications

## ColorSource gelstring

Ten frames plus leader and trailer  
Working length: 100 inches  
Overall length: 110 inches  
End to end speed: Three seconds  
Frame width: Ten inches  
Frame height: 7 1/16 inches  
Leader: Five inches wide  
Trailer: Five inches wide

## ColorSource Power Supply

12 Color Changers per power supply  
12 DMX512 channels per power supply  
Starting DMX512 channel range: 1 - 501  
DMX512 power loss bypass relay: Yes  
Voltage: 115 VAC 50/60 Hz (standard wiring),  
230 VAC  $\pm 10\%$  50/60 Hz (via internal wire changes)  
other voltages, contact Wybron  
Fuse: 2 amp slow blow at 115 VAC  
1 amp slow blow at 230 VAC  
1 line by 16 character alphanumeric display  
12 XLR 6-pin female output connectors  
DMX512 connectors input: 5-pin male XLR output  
5-pin female XLR

## DMX512 control cable

The DMX512 control signal cable from the lighting board to the Power Supply is a 5-conductor cable terminated with a standard XLR 5-pin connector. Wiring pinout is specified by the USITT DMX512/ 1990 standard.

### Control signal DMX512 pinout

Pin 1 = Common  
Pin 2 = Data -  
Pin 3 = Data +  
Pin 4 = n/c  
Pin 5 = n/c

## ColorSource cable pinout

XLR Pin #	Wire Color	Function
1	Black	Transformer center tap
2	Red	Transformer secondary
3	Brown	Transformer secondary
4	Green	Signal ground
5	White	Signal 0 - 10 Vdc
6	-----	No connection

*Note: Maximum cable length of 100 feet to each ColorSource Color Changer.*

# Parts list

To order additional Color Changers, accessories or parts, please contact your authorized ETC dealer.

## ColorSource Color Changer

CS..... ColorSource Color Changer

*ColorSource Color Changers are supplied with an installed ten color gelstring and a mounting plate. To specify the type of gelstring and mounting plate to be supplied with a ColorSource Color Changer, add the following suffixes to the catalog number. For example: CS-GS-MP75 specifies a standard gelstring and 7.5" mounting plate.*

-GS ..... Standard ten color gelstring  
-GSC ..... Custom ten color gelstring (Colors must be specified)  
-MP65 ..... Mounting plate for spotlights with 6.25" frame size (Source Four)  
-MP75 ..... Mounting plate for spotlights with 7.5" frame size (Source FourPAR)  
-MP10 ..... Mounting plate for 10" frame size (8" spotlights and conventional PARs)

## ColorSource Power Supply

*ColorSource Power Supplies come equipped with a detachable five foot power cable, DMX512 input/output connectors and power/signal connectors for up to twelve ColorSource Color Changers.*

CSPS ..... ColorSource Power Supply, 115 VAC  
CSPS-1 ..... ColorSource Power Supply, 100 VAC  
CSPS-2 ..... ColorSource Power Supply, 230 VAC  
PS-RMKit ..... Power Supply rack mounting bracket kit  
PS-PMKit ..... Power Supply pipe mounting bracket kit

## ColorSource accessories

GS ..... Standard ten color gelstring  
GSC ..... Custom ten color gelstring (Colors must be specified)  
MP65 ..... Mounting plate for spotlights with 6.25" frame size (Source Four)  
MP75 ..... Mounting plate for spotlights with 7.5" frame size (Source FourPAR)  
MP10 ..... Mounting plate for 10" frame size (8" spotlights and conventional PARs)

CSSC-10 ..... 10 foot ColorSource power/signal cable  
CSSC-15 ..... 15 foot ColorSource power/signal cable  
CSSC-25 ..... 25 foot ColorSource power/signal cable  
CSSC-50 ..... 50 foot ColorSource power/signal cable  
CSSC-75 ..... 75 foot ColorSource power/signal cable  
CSSC-100 ..... 100 foot ColorSource power/signal cable

CD-6DMX ..... 6 foot DMX512 control cable  
CD-25DMX ..... 25 foot DMX512 control cable  
CD-50DMX ..... 50 foot DMX512 control cable  
CD-100DMX .... 100 foot DMX512 control cable  
CD-150DMX .... 150 foot DMX512 control cable  
CD-200DMX .... 200 foot DMX512 control cable

## DMX512 devices

ECPB-DMX ..... 5 pin data connector wallplate with backbox  
Opto Splitter .... Various configurations available.

# Custom gelstring order form

## Standard ColorSource gelstring

<b>Frame</b>	<b>Filter Mfgr./Color number</b>	<b>Color name</b>
1	---	Clear
2	G106	Antique Rose
3	G160	Chorus Pink
4	G220	Magenta
5	G245	Light Red
6	G345	Deep Amber
7	G460	Mellow Yellow
8	G570	Light Green
9	G835	Aztec Blue
10	G940	Light Purple

## Custom ColorSource gelstring

Any combination of color filter manufacturer's gels can be combined to create a custom ColorSource gelstring. Please specify using the following format.

Specify: (L) Lee, (G) GAM, (R) Rosco with the color number and the color name.

<b><u>Frame</u></b>	<b><u>Filter Mfgr/Color number</u></b>	<b><u>Color name</u></b>
1	_____	_____
2	_____	_____
3	_____	_____
4	_____	_____
5	_____	_____
6	_____	_____
7	_____	_____
8	_____	_____
9	_____	_____
10	_____	_____

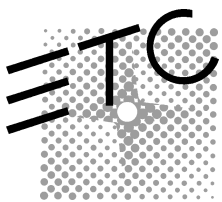

## Electronic Theatre Controls

**North America** 3030 Laura Lane • Middleton, Wisconsin 53562 • USA • Tel: (+1) 608 831 4116 • Fax: (+1) 608 836 1736

**Asia** Room 1619-20 • 16/F Metro Centre II • 21 Lam Hing Street • Kowloon Bay • Hong Kong • Tel: (+852) 2799 1220 • Fax: (+852) 2799 9325

**Home Page** <http://www.etconnect.com> • **Email** [mail@etconnect.com](mailto:mail@etconnect.com)

Copyright 1996. Specifications subject to change. 7010M1001. Revised 8/96