

Irideon AR250C

instructions
manual

Index

1. Packaging	Pag. 4
2. Transportation	.. 4
3. Important safety information	.. 4
4. Opening the projector	.. 5
5. Lamp: installation and replacement	.. 6
6. Operating voltage and frequency	.. 8
7. Installation	.. 8
7.1 Installing the unit in weather protected areas	.. 8
7.2 Installing the unit in exposed areas	.. 8
7.3 Warning	.. 8
8. Mains connection	.. 9
9. Signal connection	.. 10
9.1 Automated operation - "solo"	.. 10
9.2 Operation via DMX 512	.. 10
9.3 Synchronising multiple AR 250 C fixtures without DMX 512 signal	.. 11
10. Powering up	.. 12
11. DMX addressing	.. 13
12. Operating via DMX 512 signal	.. 14
13. Dip-switches settings for automated "solo" operation	.. 15
14. Operating multiple AR 250 C. in the absence of DMX signal	.. 16
14.1 "Master" units	.. 16
14.2 "Slave" units	.. 17
15. Dip-switch functions	.. 18
16. Auxiliary led and reset button functions	.. 19
17. Mechanical adjustments	.. 20
17.1 Tilt adjustment	.. 20
17.2 Altering beam angles by using lenses	.. 21
18. Altering the operating voltage and frequency	.. 23
18.1 Selecting the operating voltage on the autotransformer	.. 23
18.2 Selecting the operating frequency on the power supply	.. 24
19. Opening the front of the projector	.. 25
20. Thermal protection	.. 26
21. Servo-controlled fan	.. 26
22. Maintenance	.. 26
23. Electronic motor alignment	.. 27
24. Spare parts	.. 28

Congratulations on having purchased a **ETC** product. You have assured yourself of a fixture of the highest quality, both in componentry and in the technology used.

1. Packaging

Following the instructions and procedures outlined in this manual will ensure the maximum efficiency of this product for years to come.

Open the packaging and ensure that no part of the equipment has suffered damage in transit. In case of damage to the equipment, contact your carrier immediately by telephone or fax, following this with formal notification in writing.

packing list

Ensure the packaging contains:

1 AR 250 C.

- 1 owner and installation manual
- 3 optical prismatic lenses
- 1. lamp ETC PN RT172 Lamp MSD250W/2

2. Transportation

The **AR 250 C.** should be transported in its original packaging or in a **ETC** approved flight case.

During transportation, the packaging or flight case should ensure no movement of the unit.

Failure to do so may result in damage to the unit.

3. Important safety information

Fire prevention:

1. **AR 250 C** utilizes a Philips MSD 250W/2 lamp or equivalent; the use of any other lamp is not recommended and will null and void the fixtures warranty.
2. Never locate the fixture on any flammable surface.
3. Minimum distance from flammable materials: 0.5m (1.6').
4. Minimum distance from the closest illuminable surface: 2.0m (6.6').
5. Replace any blown or damaged fuses only with those of identical values. Refer to the schematic diagram if there is any doubt.
6. Connect the projector to mains power via a thermal magnetic circuit breaker.

Prevention against electric shock

1. High voltage is present in the internals of the unit. Isolate the projector from mains supply prior to performing any function which involves touching the internals of the unit, including lamp replacement.
2. For mains connection, adhere strictly to the guidelines outlined in section 7 of this manual.
3. The level of technology inherent in the **AR 250 C** requires the use of trained technicians for all service applications;
4. A good earth connection is essential for proper functioning of the projector.
Never operate the unit without proper earth connection.

Protection against ultraviolet radiation

1. Never turn on the lamp if any of the lenses, filters, or the housing is damaged; their respective functions will only operate efficiently if they are in perfect working order.
2. Never look directly into the lamp when it is operating.

Safety:

1. The projector should always be installed with bolts, clamps, and other fixings which are sufficiently rated to support the weight of the unit.
2. Always use a secondary safety chain of a sufficient rating to sustain the weight of the unit in case of the failure of the primary fixing point.
3. The external surface of the unit, at various points, may exceed 150°C (302°F). Never handle the unit until at least 10 minutes after the lamp is turned off.
4. Never install the fixture where unauthorised and untrained personnel may tamper with it.
5. Always replace the lamp if any physical damage is evident.
6. Never install the fixture in an enclosed area lacking sufficient air flow; the ambient temperature should not exceed 35°C (95.0°F).
7. A hot lamp may explode. always wait for at least 10 minutes to elapse after the unit has been turned off prior to attempting to replace the lamp. Always wear suitable hand protection when handling the lamp.

Protection rating of the body against liquids and solids:

1. The fixture has an IP 44 protection rating; this indicates that a particle larger than 1mm (0.04") cannot penetrate the unit and that it is totally protected against showers of water.
The protection rating allows the fixture to be utilized in an exposed location in inclement weather as long as it is installed according to the instructions located in section **7.2 "Installing the unit in exposed areas"**.

4. Opening the projector

Many of the operations described later in this manual can only be performed with the projector housing opened..



Attention!

Turn off the power prior to opening up the unit.

The fixtures internal temperature may reach 250° C (482° F) after 5 minutes, with a maximum peak of 350°C (662° F). Ensure the lamp is cold prior to attempting removal. The fixture should be allowed to stand and cool for 10 minutes prior to its removal.

To access the internals of the projector, proceed as follows:

- 1) Using a Philips head screwdriver, loosen and remove the 11 screws (**A**) which affix the rear housing (**B**) of the projector body. Care should be taken during this operation to not drop and lose the screws.



- 2) Remove the cover (**B**) from the central seal.

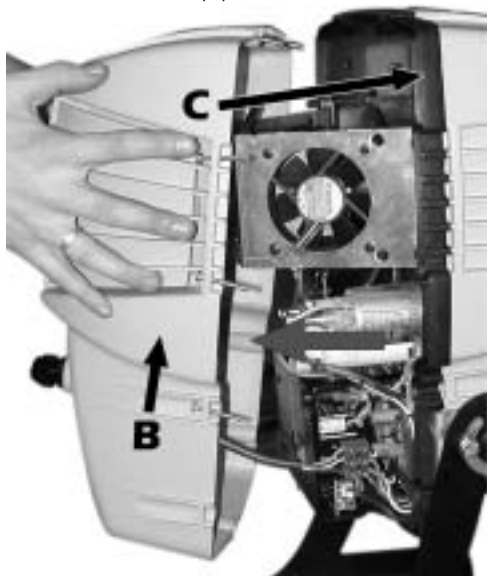

- 3) You should now have access to the internals of the unit and may carry out the instructions detailed below.

Important Note:

To close the unit, you must ensure that the rear cover (**B**) is properly seated in the central seal (**C**) and then replace and fasten the 11 screws. The **AR 250 C** will only maintain its weather-resistance if this procedure is carried out with scrupulous attention to detail.

5. Lamp: installation and replacement

The **AR 250 C** utilizes a Philips MSD 250W/2 or Philips MSD 250W lamp or equivalent.

MSD 250W/2

power	250 w
luminous flux	18.000 lm
color temperature	8.500° K
base	GY 9,5
approximate lamp life	2000 hours

MSD 250W

power	250 w
luminous flux	18.000 lm
color temperature	6.700° K
base	GY 9,5
approximate lamp life	2000 hours

To access the lamp, you should proceed as described in section 4 of this manual.

MSD lamps are part of the mercury vapour family of discharge lamps and must be handled with great care. the lamp operates at high pressure, and the slight risk of explosion of the lamp exists if operated over its recommended life. We recommend, therefore, that the lamp be replaced within the manufacturers specified lamp life.

- 1) Locate the lamp assembly and, using a Philips head screwdriver, loosen the three screws (**C**) which affix the assembly.



- 2) Remove the lamp assembly (**D**). Care should be taken to avoid damaging the cables when extracting the assembly.

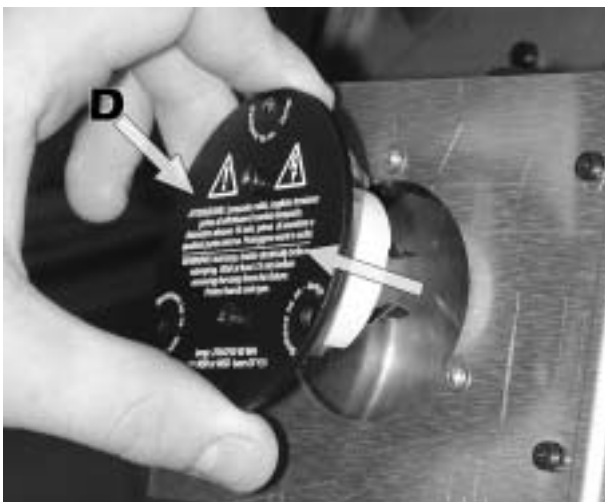

- 3) Locate the lampholder (**E**)

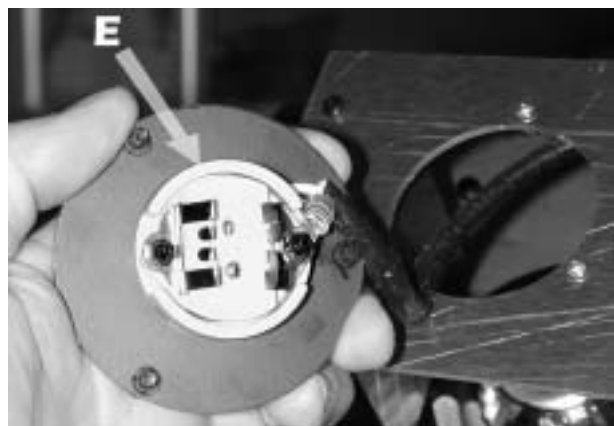

4) Insert the lamp into its base (**E**).

The lamp used is manufactured from quartz glass and should be handled with care. Always adhere to the instructions supplied in the lamps packaging. Do not touch the glass directly, use the cloth provided with the lamp. The GY 9,5 lampholder is asymmetrical in construction, with one pin larger than the other. Ensure that the pins are correctly aligned with the appropriate socket. **DO NOT USE UNDUE FORCE.** In case of difficulty, re-read the instructions and repeat the procedure.



5) Replace the lamp into its original position and replace and retighten the 3 screws which were previously removed.



Do not close the unit until all the operations have been performed on the display panel internal to the **AR 250 C**.

6. Operating voltage and frequency

The fixture may operate at voltages 100, 115, 208, 230 or 240V at 50 or 60 Hz. preset is indicated on the sticker located on the base of the projector, as indicated in the following diagram.

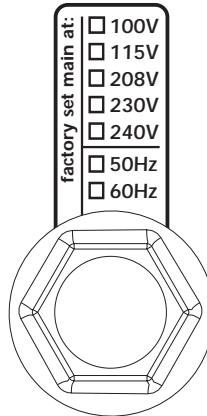

If the specified voltage and frequency do not match those of the country in which you are operating, follow the instructions in section 19 of this manual. "Altering the operating voltage and frequency"

Incorrect voltage and frequency selection will detrimentally affect the operation of the projector.

7. Installation

Due to its high protection rating **AR 250 C** may be installed in a variety of locations, both indoors and in areas exposed to the elements.

7.1 Installing the unit in weather protected areas.

AR 250 C. may be situated in any mounting position when operated in sheltered areas.

In order to allow it to be installed in a variety of locations, the **AR 250 C** is provided with 5 mounting holes (A) of \varnothing 13mm on its base; for permanent and secure mounting on any surface.

If hanging the unit from ceiling or a structure, you may utilize the holes (A) which allow for the attachment of a "c" clamp at any position through 360°. The structure from which the unit is hung should be of sufficient rating to hold the weight of the unit, as should any clamps used to hold the unit.

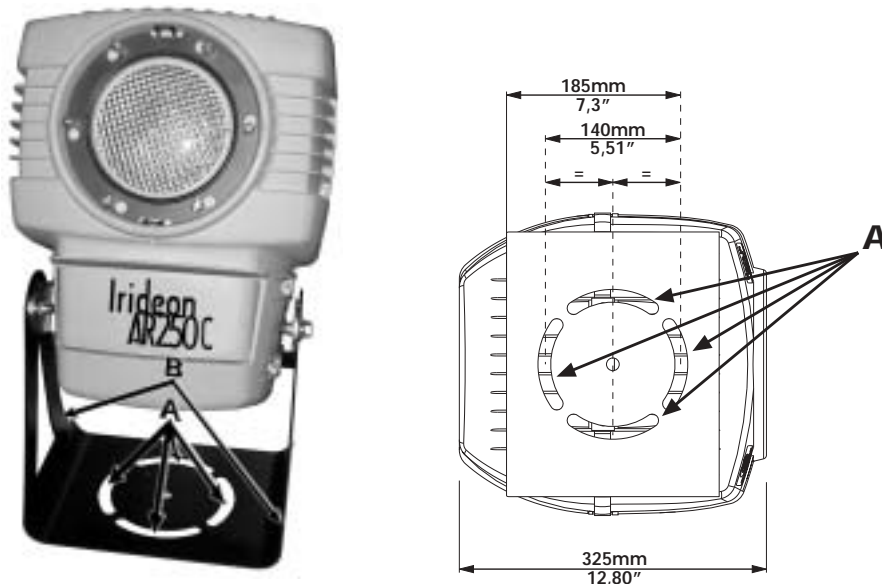

7.2 Installing the unit in exposed areas

The **AR 250 C** may be situated in several mounting positions when installed in an exposed area, thanks to its IP 44 protection rating. To ensure proper installation, however, there is a simple guideline to follow:



Attention!

As shown in the diagram, base of the unit must always be facing the ground.

The **AR 250 C** may be adjusted from -45° to $+90^\circ$. without having to move any other component except the head of the fixture. Installation in any position other than with the base down, will cause the projector to not perform with its maximum protection rating.

Installing the unit incorrectly may cause damage to occur and will immediately void the warranty.

7.3 Warning safety chain

When hanging the **AR 250 C** we recommend the use of a safety chain, affixed to the appropriate hole (B) on the yoke of the **AR 250 C** and to the suspension device.

This secondary safety attachment should be done using either a metal wire rope or a metal chain, both suitably rated for the purpose.

risk of fire

Every projector produces heat, and should therefore be installed in a well-ventilated position. The minimum distance from flammable materials: 0.5m (1.64'). The minimum distance from the object being illuminated: 2.0m (6.6').

8. Mains connection

cabling

The mains cable provided is thermally resistant, complying to the most recent international standards.

In case of cable replacement, similar cable with comparable thermal resistant qualities must be used exclusively (cable 3x1.5 external 10mm (0.4"), rated 300/500V, tested to 2KV, operating temperature -40°C (-40°F) +180°C (356°F).

mains connection

AR 250 C can operate at voltages from **100V, 115V, 208V, 230V, 240V** at **50** or **60Hz** (operating voltage and frequency can be selected as described in section 6 and 19 of this manual). Prior to connecting the unit to your mains supply, ensure that the model in your possession correctly matches the mains supply available to you.

For connection purposes, ensure your plug is of a suitable rating:

at **230 V**: 2 Amps on startup, 1,6 amps constant draw in normal operation

a **115 V**: 4,2 Amps on startup, 3,2 amps constant draw in normal operation

Locate the mains cable which exits the base of the unit and connect as shown below:

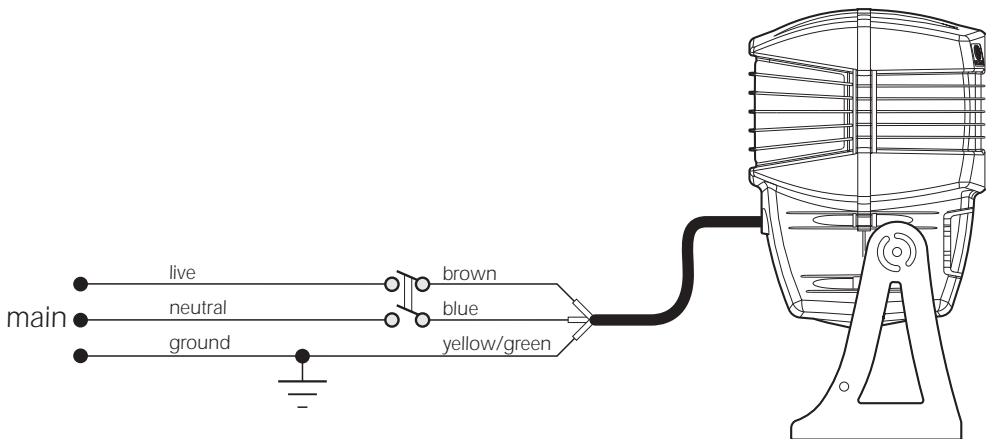

protection

The use of a thermal magnetic circuit breaker is recommended for each **AR 250 C**.

A good earth connection is essential for the correct operation of the fixture. Strict adherence to regulatory norms is strongly recommended.



Warning: AR 250 C. must be earthed; never install the unit unless the yellow/green earth cable is securely connected.

9. Signal connection

AR 250 C may operate in 3 different modes:

9.1 Automated operation

9.2 Using DMX 512 signal

9.3 Synchronising AR 250 C without DMX 512 signal.

Follow the instructions below which relate to your particular application:

9.1 Automated operation "solo"

AR 250 C. may operate in stand alone mode in the absence of control signal, using a pre-programmed color changing sequence which can be activated by the dip-switches on the rear panel of the unit.

9.2 Using DMX 512 signal

Control signal is digital, and is transmitted via two pair screened 0.5mm cable.

Connection is serial, utilising the data cables sockets located on the base of the AR 250 C.

signal connection

Connection is to international standards:

- Pin 1 gnd = shield
- Pin 2 data - = black
- Pin 3 data + = white

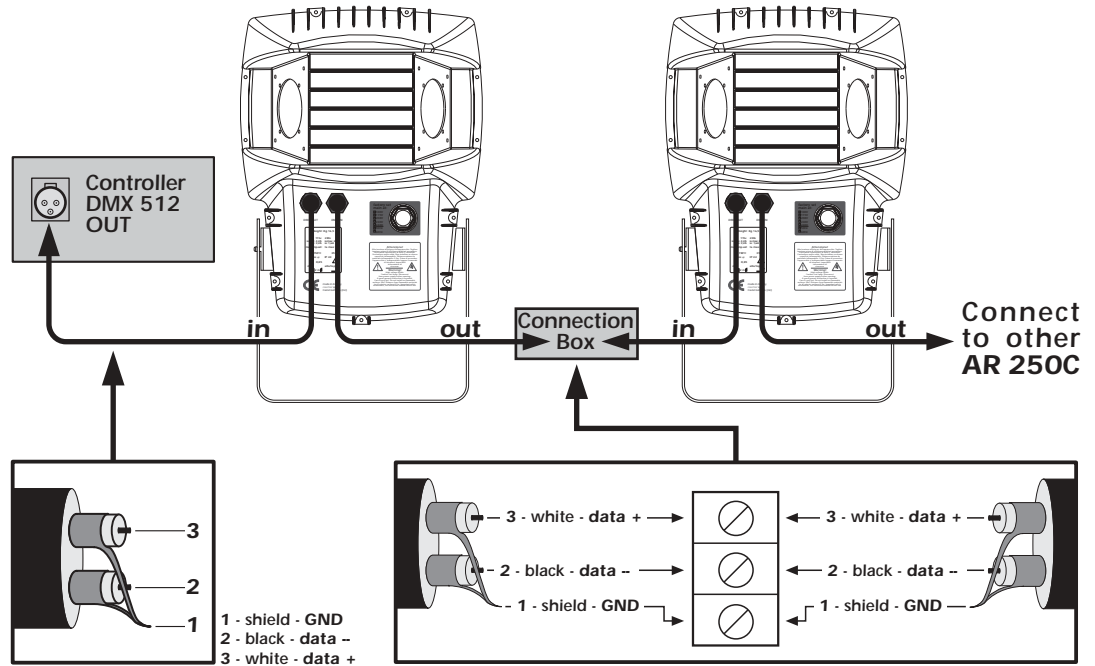

9.3 Synchronizing AR 250 C without DMX 512 signal.

Multiple **AR 250 C** units may be interconnected in the absence of **DMX 512** signal, operating simply via the inbuilt programs within the **AR 250 C**.

All **AR 250 Cs** connected will operate **simultaneously** with one unit acting as **MASTER** and all subsequent units as a **SLAVES**.

Determine which of the **AR 250 C** will act as master.

Connection should be to international standards:

- Pin 1 gnd = shield
- Pin 2 data - = black
- Pin 3 data + = white

Ensure that all data conductors are isolated from one another and the metal housing of the connector.

Pin 1 should never be connected to mains power.

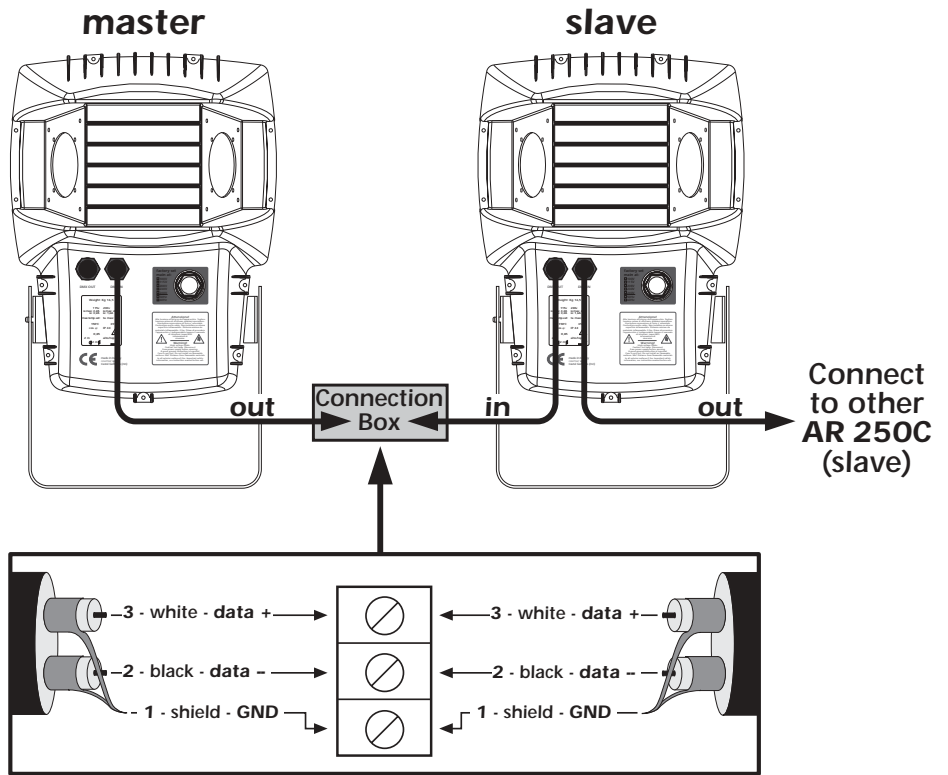

Important Information

To perform the operations which follow, from sections **10** to **16**, with the exception of **15**, the projector housing should be open. If you have since closed the unit up, reopen the housing as described in section **4**.

10. Powering up

After having followed the preceding steps, turn on power to the unit.

If you have chosen to control the **AR 250 C** using a **DMX 512** controller, you should always turn on the power to the controller first.

The fixture will perform a reset function on its internal motors. This will last 30 seconds, after which it will be subject to the external signal from the controller.

Ventilation

The projector is fitted with 2 fans for forced cooling of the unit.

The two fans are directly controlled by the on-board software and may be switched off on powering up, depending upon the settings of the units dip switches. They may never be switched off when the lamp is turned on.

To turn the fans on, you will need to switch on the lamp or alter the fan dip switch setting to ON. Factory default setting for dip-switches are DMX Address "1" lamp on.

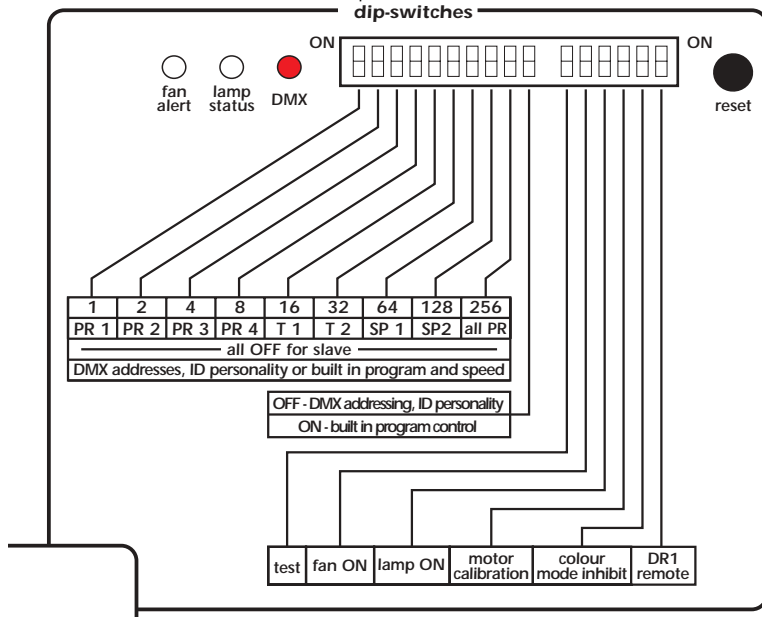

DMX 512 signal reception

Upon being powered up, the projector will proceed with its reset function. On completion of this, the led will flash if the projector is correctly receiving **DMX 512** signal.

If the led remains off, the projector is not receiving signal correctly. Check the cabling and the functioning of the controller.

turning on the power with no dmx signal connected

After being powered up, the projector will perform a reset. When completed, the led will remain off, indicating that the fixture is not receiving **DMX 512** control signal.

11. DMX addressing

Each **AR 250 C** utilizes **4 channels of DMX signal for complete control of all its functions.**

To ensure that each unit accesses the correct signal, it is necessary to correctly address each fixture. Any number between 1 and 508 can be generated via the dip-switches of the **AR 250 C.**

This procedure must be carried out on every unit being utilized, positioning the dip-switches to either **ON** or **OFF** depending upon what **DMX** address is required.

The **DMX** address of a particular projector is the sum total of the dip-switches settings, for example:

DMX 42 is obtained by switching the dip-switches values **32+8+2** to **ON**

DMX 82 is obtained by switching the dip-switches values **64+16+2** to **ON**

The diagram below shows how to set the dip switches to their **ON** position, setting the address to **DMX 1**. Obviously, any **DMX** address can be achieved by adding together the values achieved when switching on the respective dip switches.

es. **dmx address n° 1**

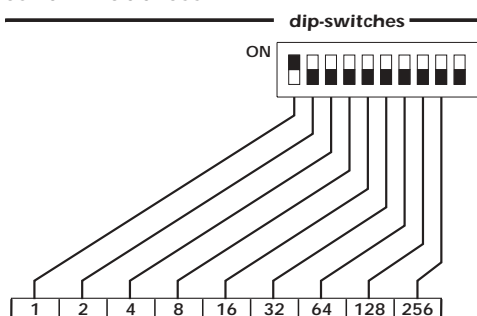

The first projector will utilize **DMX** address 1; a projector thus addressed will respond to commands on channels **1** to **4** from the **DMX 512** controller. A second projector should be addressed as **5** a third as **9** and so on until the final unit has been addressed.

Ensure that none of the **DMX** values you assign overlap. This will ensure that each projector can have all its functions individually addressed by the console.

To learn further about the individual operation of each function of the **AR 250 C**, refer to section 12 of this manual "**Operating via DMX 512 signal**".

12. Operating via DMX 512 signal

AR 250 C is able to operate via **DMX 512** signal. Connection should be as described as in section "9.2 Operation via DMX 512 signal".

If the instructions in this manual have been carried out to this point, the 6 channels of your **DMX 512 controller will have control over all the functions of the AR 250 C** as shown in the following table.:

channel	function	type of control	effect	decimal	percentage
1	colors	step	Open/white	0-24	0-9.4
		step or proportional depending on ch. 2	color 1	25-49	9.8-19.2
		step or proportional depending on ch. 2	color 2	50-74	19.6-29
		step or proportional depending on ch. 2	color 3	75-99	29.4-38.8
		step or proportional depending on ch. 2	color 4	100-127	39.2-49.8
		proportional	Forwards rainbow effect from fast to slow	128-190	50.2-74.5
		step	No rotation	191-192	74.9-75.2
		proportional	Backwards rainbow effect from slow to fast	193-255	75.6-100
2	color mode	step	colors (channel 1) steps	0-127	0-49.8
		step	colors (channel 1) proportional	128-255	50.2-100
3	Auto function	step	No effects	0-9	0-3.5
		proportional	Auto program 1 (color sequence without white) speed from fast to slow	10-61	3.9-23.9
		proportional	Auto program 2 (full color sequence) speed from fast to slow	62-113	24.3-44.3
		proportional	Auto program 3 (color sequence with half color) speed from fast to slow	114-165	44.7-64.7
		proportional	Auto program 4 (color sequence including continuous rotation, speed from fast to slow)	166-217	65.1-85
		step	Random program	218-240	85.4-94.1
		step	All programs	241-255	94.5-100
4	Lamp on/off/ reset program wait time control	step	Park (no function)	0-10	0-3.9
		step	lamp off	11-30	4.3-11.7
		step	motor reset (only once)	31-60	12.1-23.5
		step	Program stop	61-80	23.9-31.3
		proportional	Selected auto-program pause time control (1 sec/5 min)	81-241	31.7-94.5
		step	lamp on	242-255	94.9-100
Dip-switches can inhibit lamp off function					
note 1: lamp on/off and reset have a delay time of 6 second to prevent accidental activation.					
note 2 :on/off lamp mode is not affected unless an opposite value is received					
note 3 :Dip-switch 14 ON change channel 3 function					
3	color wheel off-set	proportional	proportional offset of the colour wheel motor, press reset button to record	0-255	0-100
Fixture type: AR 250 C			Chart name: DMX 512		
			Date: 05/2002		

to ignite the lamp

to ignite the lamp channel 4 must have a value between 242 and 255; to turn it off, channel 4 must have a value between 11 and 30.



The lamp can be set to ignite by default by setting dip switch **#3** to **On**. Once the lamp is on, the lamp status led will illuminate. Dip switch #3 in the On position will supercede **DMX** control.

13. Dip-switch settings for automated "solo" operation.

AR 250 C can operate automatically, running a series of internally recorded programs whose settings are determined by the dip switch settings imposed by the operator.

No signal cable should be connected to the fixtures data input, as described in section 9.1 "Signal connection for automated "solo" operation".

Activating automated operation

Set to **ON** the dip-switch named **On-built in program control**. From this moment, the dip-switches 1 to 9 may be used to adjust the various parameters for automated color changes: program selection, fade times and speed.

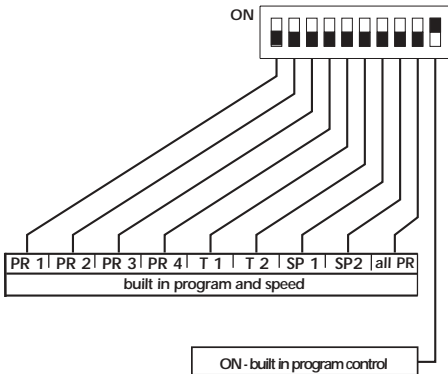

Selecting automated color change programs.

Dip-switches from **PR1** to **PR4** (program 1 to program 4), when switched to the **ON position**, activate preset color change programs.

The **4 in-built programs** have the following features:

- Program **1**: all colors, with the exception of open white, in a smooth, slow crossfade sequence
- Program **2**: all colors in a smooth, slow crossfade sequence
- Program **3**: all colors, with the exception of open white, in sequence.
- Program **4**: all colors in sequence.

Important note:
Only one program at a time may be selected.

Selecting the hold time

Dip-switches **T1** and **T2** allow for one of 4 hold times for the various colors

T1	T2	t (sec.)
off	off	3
on	off	10
off	on	30
on	on	60

Selecting the fade speed

Dip-switches **SP1** and **SP2** allow for one of 4 fade times to be selected:

SP1	SP2	speed
off	off	fast
on	off	medium
off	on	medium slow
on	on	slow

All programs in continuous sequence

Dip switch **All PR** in the **ON** position allows for all programs to be replayed in sequence automatically and continuously.

14. Operating multiple AR 250 C in synchronised mode without DMX 512

Multiple **AR 250 C**. can be operated in the absence of control signal by executing internally stored, pre-recorded programs. Projectors correctly connected together may operate in synchronised mode, the **AR 250 C** receiving signal being denominated as “**slave**” units and those generating control signal designated as “**master**” units. To activate this automated function, projectors must be connected together as described in the section entitled **9.3. “Synchronising multiple AR 250 C fixtures without using DMX 512”**; No signal cables should be connected to the external XLR3 sockets. Power up the projector and use the dip-switches to adjust to the correct settings.

14.1 “Masters”

AR 250 C may operate automatically with output in the form of pre-recorded programs, as described in section “**9.3. Synchronising multiple AR 250 C fixtures without using DMX 512**” Only one unit may be designated as “**master**”. Selecting a master unit is simply a matter of convenience and accessibility to the dip-switches:

Activating “auto” mode

Set to **ON** the dip-switch named **On-built in program control**. From this moment, the dip-switches **1** to **9** may be used to adjust the various parameters for automated color changes: program selection, fade times and speed.

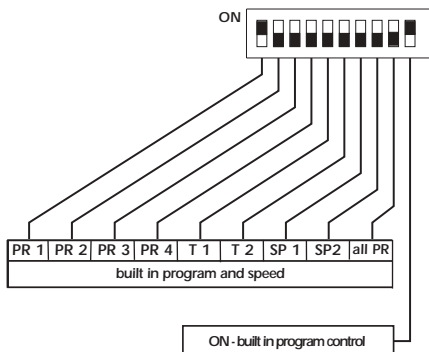

Selecting automated color change programs.

Dip-switches from **PR 1** to **PR 4** (program 1 to program 4), when switched to the **ON position**, activate preset color change programs.

The **4** inbuilt programs have the following features:

Program **1**: all colors, with the exception of open white, in a smooth, slow crossfade sequence

Program **2**: all colors in a smooth, slow crossfade sequence

Program **3**: all colors, with the exception of open white, in sequence.

Program **4**: all colors in sequence.

Important note:

Only one program at a time may be selected.

Selecting the hold time

Dip-switches **T 1** and **T 2** allow for one of **4** hold times for the various colors

T1	T2	t (sec.)
off	off	3
on	off	10
off	on	30
on	on	60

Selecting the fade speed

Dip-switches **SP 1** and **SP 2** allow for one of **4** fade times to be selected.

SP1	SP 2	speed
off	off	fast
on	off	medium
off	on	medium/slow
on	on	slow

Running programs in a continuous sequence

Setting dip-switches **All PR** in the **ON** position causes all the pre-recorded programs to run in an automated continuous sequence.

14.2 "slaves"

All projectors which are connected to a "Master" unit should be set to "Slave". Connections should be as described in section "9.3 Synchronising multiple AR 250 C fixtures without DMX 512".

"Slave" units are recognisable since they have connections made to both XLR sockets in their base, except for the final unit in the chain which has only one connection to its "DMX IN".socket.

To set projectors to "Slave" mode, it is necessary to simply set dip-switches **1** to **9** in the **OFF** position and the **On-built in program control dip switch to ON**

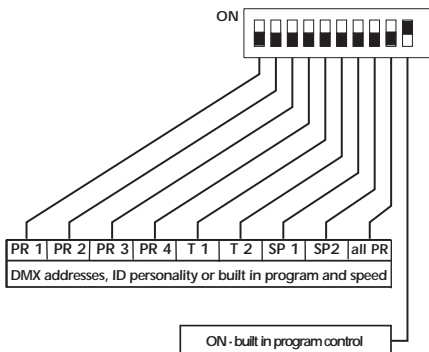

15. Dip-switch functions

The control panel of the **AR 250 C** is fitted with a further 6 additional dip-switches to those described in section 13. These are used to alter several parameters of the unit.

Testing the projector

Setting the test dip-switch to the **ON** position will cause the **AR 250 C** to carry out a self-test function.

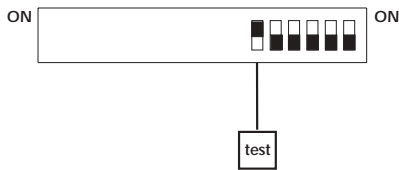

Fans

Setting the fan dip-switch to the **ON** position will cause the fans to remain on at all times the projector is powered up. In the **OFF** position, the fans will operate only when the lamp is switched on.

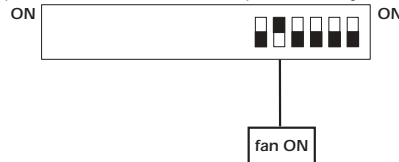

Lamp control

With the lamp dip-switch in the **ON** position, the lamp will remain on at all times the projector is powered up. In the **OFF** position, the lamp will be controlled via **DMX** signal.

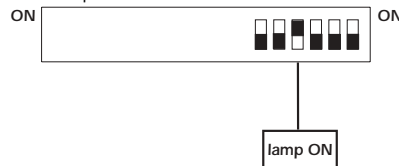

Motor calibration

The motor calibration dip-switch in the **ON** position will allow for motor offsets to be recalibrated.

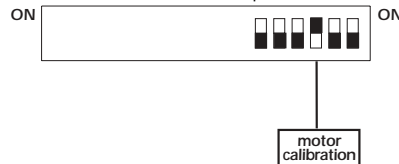

For further information about this, read section 24. **Electronic motor alignment**.

Inhibiting color changes

The color mode dip-switch will inhibit color change when in the **ON** position by over-riding **DMX** channel 2 (which controls color changing).

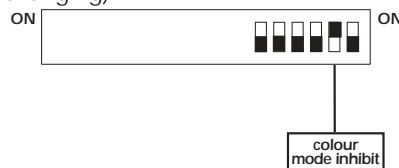

16. Auxiliary led and reset button functions

Led: Fan alert

The **Fan alert led** indicates that the fans have malfunctioned:
 Led **ON**: one or other of the fans are not operating - test them separately.
 Led **OFF**: correct fan operation

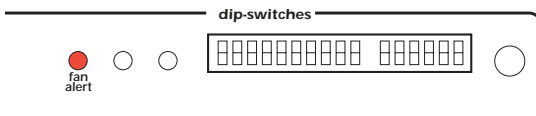

Led: Lamp status

The **lamp status led** indicates the lamp functioning:
 Led **ON**: lamp is on
 Led **OFF**: lamp is off

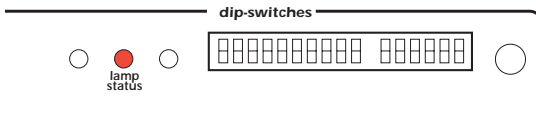

Led: DMX

The **DMX led** indicates the DMX input state:
 Led flashing **ON**: signal is present
 Led **OFF**: no signal present

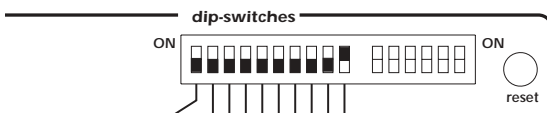

Reset button

Pressing the **reset** button will cause the fixture to recalibrate its motors.

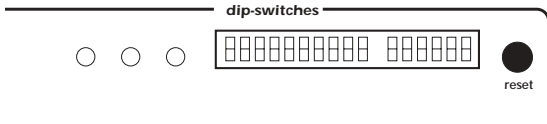

17. Mechanical adjustments

After having powered up the projector and having established **DMX 512** control or set it to operate automatically, the following mechanical adjustments should be carried out in order to maximise the output of the projector in its current installation.

17.1 Adjusting tilt angle

Loosen the two adjustment bolts on the sides of the body which allow the body to tilt (+90° -45°).



After having adjusted the unit to the required tilt, firmly tighten both bolts to avoid the unit slipping out of position.

17.2 Altering beam angles by inserting lenses.

Several optional and interchangeable lenses may be used to vary the beam characteristics in particular applications.

All filters are rotatable through 360°

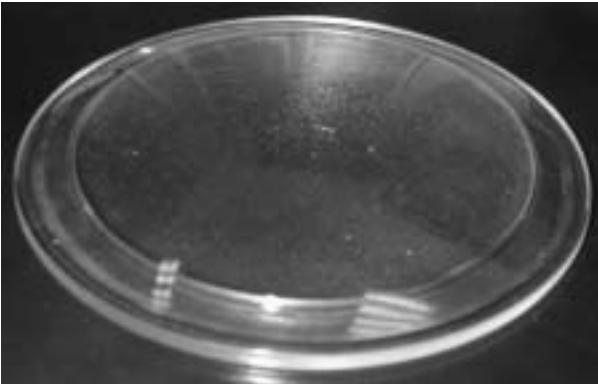

- Beam shape: circular

Diffusion lens

1/2 peak angle: $9,5^\circ$

1/10 peak angle: 20°

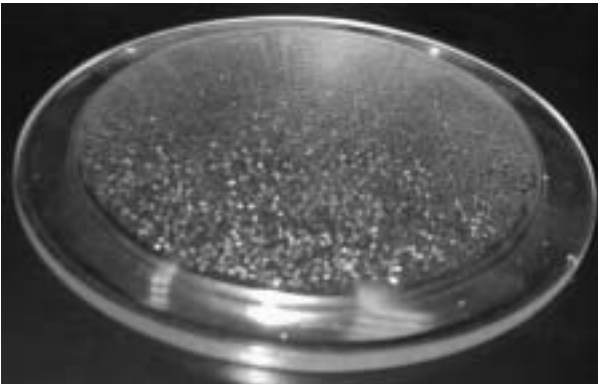

- Beam shape: circular

Prismatic, semi-diffusion lens

1/2 peak angle: $13,5^\circ$

1/10 peak angle: 31°



- Beam shape: square

Prismatic, maximum diffusion lens

1/2 peak angle: 71°

1/10 peak angle: 71°

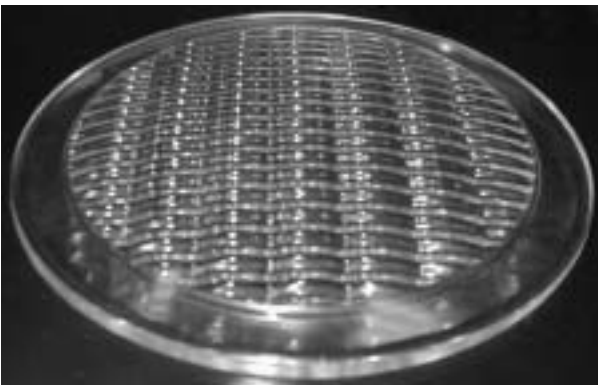

- Beam shape: rectangular

Prismatic outline/shaped lens

vertical projection

1/2 peak angle: 24°

1/10 peak angle: 40°

horizontal projection

1/2 peak angle: 55°

1/10 peak angle: 68°

English

Prior to changing lenses, it is advisable to turn off the lamp; to facilitate the replacement operation, it is advisable to rotate the body of the projector through 90° with respect to the base.



Attention
Direct exposure to the output of the unit is not recommended.

- 1) Loosen the 6 screws (A) using an appropriate screwdriver.



- 2) Rotate and remove the fixing ring.



- 3) Remove the currently installed lens.



- 4) Insert the new lens most suited to your particular application. All lenses are rotatable through 360°

- 5) After having inserted a new lens, replace the retaining ring and refasten the screws.
Care should be taken in carrying out this procedure; the seal should be correctly seated and the screws should be firmly tightened in order to maintain the protection rating of the unit.

The drain hole.(see diagram) should never be obstructed.



18. Manually altering the operating voltage and frequency (Reserved for technical staff only)

If the factory preset operating voltage and frequency do not correspond to those in use in your country of operation, you may alter the settings as described in the following paragraphs.

Incorrect selection of operating voltage and frequency will seriously compromise the functioning of the projector.

Opening the projector

To carry out the following procedures, the projector housing should be open, Instructions for opening up the unit can be found in section 4 of this manual.

18.1 Selecting the voltage on the autotransformer

After having opened up the rear of the unit:

- 1) Locate the circuit board panel and remove the screws which fix it in place

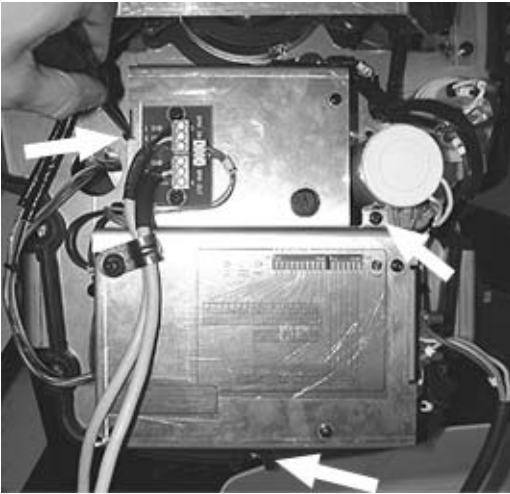

- 2) Locate the autotransformer on the left of the unit.
- 3) Disconnect cable 8 and move it to the required voltage. To ensure the correct selection, refer closely to the sticker attached to the autotransformer (240/230/208/115/100).



Connection 9 should not be moved under any circumstances. If in doubt, consult the circuit diagram or refer the unit to specialist trained personnel.

- 4) For voltages in the range 208/230/245 V, utilize a fuse rated at 5Amp T (Time Delay) 250 VAC 5 x 20mm Ceramic. For voltages in the range 100/115V utilize a fuse rated at 8 Amp T (Time Delay) 115 VAC 5 x 20mm Ceramic, as indicated in the diagram.



- 5) Operating frequency may now be set (if necessary) as shown in the next section.

18.2. Selecting the frequency of the power supply of the AR 250 C.

After having removed the rear panel of the **AR 250 C.** and removed the circuit board panel, as shown previously:

- 1) Locate the power supply on the right of the base.
- 2) Select from either 50 or 60Hz by moving cables 10 and 11 to the required position. To ensure you have selected the correct tap, refer to the sticker located on the power supply.



- 3) Connection 16 should not be moved under any circumstances. If in doubt, consult the circuit diagram or refer the unit to a trained technician.



Attention!

Incorrect selection of either the voltage or the frequency will immediately null and void the warranty of the fixture and may cause irreparable damage.

19. Opening the front of the projector (reserved for technical staff)

Several maintenance operations may require the front housing of the unit to be removed.

Attention!

Remove mains power prior to opening up the unit.

The internal temperature of the unit may reach 250°C (482°F) after 5 minutes, with a peak of 350°C (662°F). Ensure that the lamp is cool prior to removing. The projector should only be opened after it has been allowed to stand and cool for 10 minutes after it has been turned off.

After having opened up the rear housing of the **AR 250 C** as described in section 4, proceed as follows:

1) Loosen the 6 screws (A) using an appropriate screwdriver.



2) Rotate and remove the fixing ring.

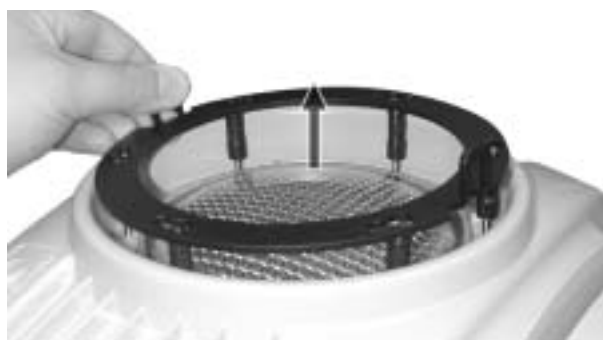

3) Remove the lens.



4) Remove the 2 screws (B).



5) Slide the front housing of the unit away from the rubber seal.

NOTE: When replacing the housing, you must ensure that the housing (B) is seated correctly into the rubber seal (C); then replace and retighten all the screws.

The procedure must be strictly adhered to to ensure that the **AR 250 C** maintains its protection rating.

20. Thermal protection

A thermal sensor in the body of the **AR 250 C** protects the fixture against over heating.

The sensor operates by removing power to the lamp should the operating temperature exceed the factory preset. This may be due to several factors, including the lack of circulation around the unit, high ambient temperature, or the malfunction of an on-board fan. The sensor will reset itself once the temperature has returned to an acceptable level, and will continue to monitor the internal temperature of the unit.

21. Servo-controlled fans

The 2 fans are controlled by a servo-control system. The main PCB provides power to the fans and keeps track of the fan blade speed. If a discrepancy exists between the fan speed and the expected fan speed, the lamp will be automatically turned off after 5 seconds of incompatible signals.

In the case of fan malfunction, after the lamp has turned off, the fan led will turn on to notify the user that there has been a fan failure. Should this occur, we recommend that you open up the projector housing and clean the fans thoroughly, as this is generally the main cause of problems in this area.

22. Maintenance

While every possible precaution has been taken to ensure the trouble-free operation of your **AR 250 C**, the following periodic maintenance is highly recommended. We recommend that the voltage to the unit be removed prior to any maintenance procedure taking place.

Attention

The housing may be opened as described in section 4

Periodic cleaning

Even a fine layer of dust can reduce the luminous output substantially. Regularly clean all lenses, dichroic filters and the reflector using a soft cotton cloth, dampened with a specialist lens cleaning solution.

Fans and air passages

The fans and air passages must be cleaned approximately every 6 weeks. Time between cleaning will vary due to site specific conditions in which the projector is operating. Suitable tools for performing this type of maintenance are a brush and a common vacuum cleaner or an air compressor.

The fans are located beside the lamp assembly.

Air intakes

The air intakes require regular cleaning to maximise the efficiency of the cooling system. These intakes should be cleaned approximately every 4 weeks. Time between cleaning will vary due to site specific conditions in which the projector is operating. Suitable instruments for performing this type of maintenance are a brush and a common vacuum cleaner or an air compressor. Should this not suffice, it may be advisable to soak the intakes in a detergent solution.

Filters and dichroics

For a thorough cleaning of the filters and dichroic lenses, it may be best to refer the unit to a trained technician, as they are located internally to the unit.

Periodic maintenance

Lamp

The lamp should be replaced at end of life or if there is any observable damage or deformation due to heat. This will avoid the danger of non-passive end of life.

Mechanicals

Periodically check all mechanical devices for wear and tear, replacing them if necessary. Periodically check the lubrication of all components, particularly the parts subject to high temperatures. If necessary, lubricate with suitable lubricant, available from your **ETC** distributor. It is strongly suggested the use of an oil-based product rather than a greasy lubricant, to avoid the accumulation of dust and the consequent clogging of the mechanisms. Also, make sure you run this maintenance routine regularly and thoroughly.

Electronic components

Check all electrical components for correct earthing and proper attachment of all connectors, refastening if necessary.

Replacing the fuse

The **AR 250 C**. is fitted with two fuses. To replace the fuse, it is necessary to remove the rear housing, as previously described in this manual. The two fuses are located on the rear panel and the motor control circuit board. Use a multimeter to check the fuse, replacing any faulty or damaged fuses with ones of equal value, dimensions and characteristics. These are described on the adjacent sticker.

115VAC units--Fuse 5Amp T (Time Delay) 250VAC 2x20mm Ceramic.

230VAC units--Fuse 8Amp T (Time Delay) 115VAC 5x20mm Ceramic.



Attention!

Once maintenance has been completed, ensure that all seals are replaced correctly when refitting the housing. Failure to do so will result in the unit not maintaining its protection rating and may result in damage occurring.

23. Electronic motor alignment



Attention

This section is reserved for technicians only.

The **AR 250 C** allows for the electronic alignment of the projector's motors. This procedure is performed at the factory. It may be useful to perform this procedure in the case of internal components being replaced.

Altering the factory settings may radically alter the functioning of the projector. Carefully read all of the following prior to attempting any changes.

electronic calibration

IMPORTANT NOTE: This procedure can only be undertaken if the projector is correctly receiving **DMX 512** signal.

To undertake this procedure:

1) Select a **DMX** number as required from **1** to **512** by moving the respective dip-switches to the **ON** position, while simultaneously selecting the **motor calibration**.

From this moment on, the third **DMX** channel pertaining to this fixture, say **DMX 3**, no longer allows for program selection, (as shown in the **DMX** table), but now controls the motor offset of the color wheel. The other functions on respective channels **DMX 1, 2** and **4** remain the same.

For example, **DMX address 1:**

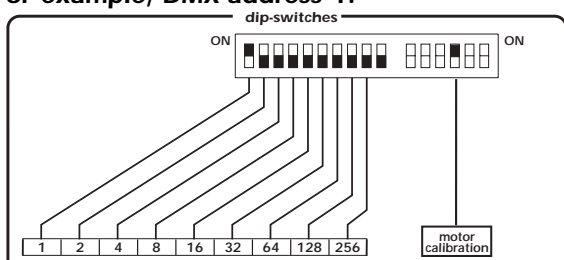

2) Insert a color into the beam of light controlled by **DMX 1**

3) Adjust the offset (calibration) of the color wheel by utilising control channel **DMX 3**.

4) Check the alignment of the individual color in the optical path of the projector controlled by channel 1.

5) When the desired offset has been obtained, press the reset button to record the calibration setting.

channel	function	type of control	effect	decimal	percentage
1	colors	step	Open/white	0-24	0-9.4
		step or proportional depending on channel 2	color 1	25-49	9.8-19.2
		step or proportional depending on channel 2	color 2	50-74	19.6-29
		step or proportional depending on channel 2	color 3	75-99	29.4-38.8
		step or proportional depending on channel 2	color 4	100-127	39.2-49.8
		proportional	Forwards rainbow effect from fast to slow	128-190	50.2-74.5
		step	No rotation	191-192	74.9-75.2
		proportional	Backwards rainbow effect from slow to fast	193-255	75.6-100
2	color mode	step	colors (channel 1) steps	0-127	0-49.8
		step	colors (channel 1) proportional	128-255	50.2-100
3	color wheel off-set	proportional	proportional offset of the colour wheel motor, press reset button to record	0-255	0-100
4	Lamp on/off/reset program wait time control	step	Park (no function)	0-10	0-3.9
		step	lamp off	11-30	4.3-11.7
		step	motor reset (only once)	31-60	12.1-23.5
		step	Program stop	61-80	23.9-31.3
		proportional	Selected auto-program pause time control (1 sec/5 min)	81-241	31.7-94.5
		step	lamp on	242-255	94.9-100

English

To return to normal operation, return the motor calibration dip-switch to the **OFF** position.

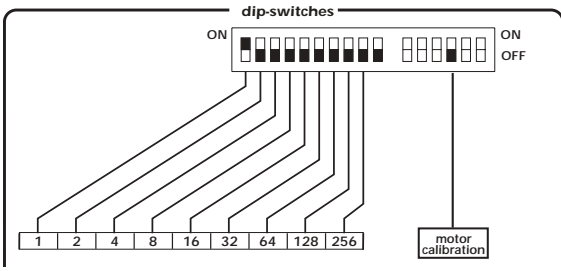

24. Spare parts

Spare parts for the AR 250 C are available from ETC

Accurate description of the fixture, model number, and type will assist us in providing for your requirements in an efficient and effective manner.



Americas ■ 3030 Laura Lane, P.O. Box 620979, Middleton, Wisconsin 53562-0979 USA ■ Tel: +608 831 4116 ■ +800 688 4116 ■ Fax: +608 836 1736 ■ +800 555 8912
Europe ■ Unit 5, Victoria Industrial Estate, Victoria Road, London W3 6UU, UK ■ Tel: +44 (0)20 8896 1000 ■ Fax: +44 (0)20 8896 2000
Asia ■ Room 605-606, Tower III Enterprise Square, 9 Sheung Yuet Road, Kowloon Bay, Kowloon, Hong Kong ■ Tel: +852 2799 1220 ■ Fax: +852 2799 9325
Web: www.etconnect.com ■ Email: (US) mail@etconnect.com ■ (UK) mail@etceurope.com ■ (Asia) mail@etcasia.com
Service: service@etconnect.com ■ Toll free: 800 775 4382 ■ Comments about this document: techcomm@etconnect.com
Copyright © 2003 Electronic Theatre Controls, Inc. All Rights Reserved. Product information and specifications subject to change.
© 7095M1002 ■ Rev A ■ Released 5/31/02