

L86-DIMMER PACKS

Plug in Dimmers

Plug in Electronics

*Multi-Format
Control Capability
DMX-512,
AMX-192,
0-10vdc Analog,
Micro II*

1 \emptyset -3 \emptyset Power

*Filtered Forced
Air Cooling*

*UL Listed
File #E92134*

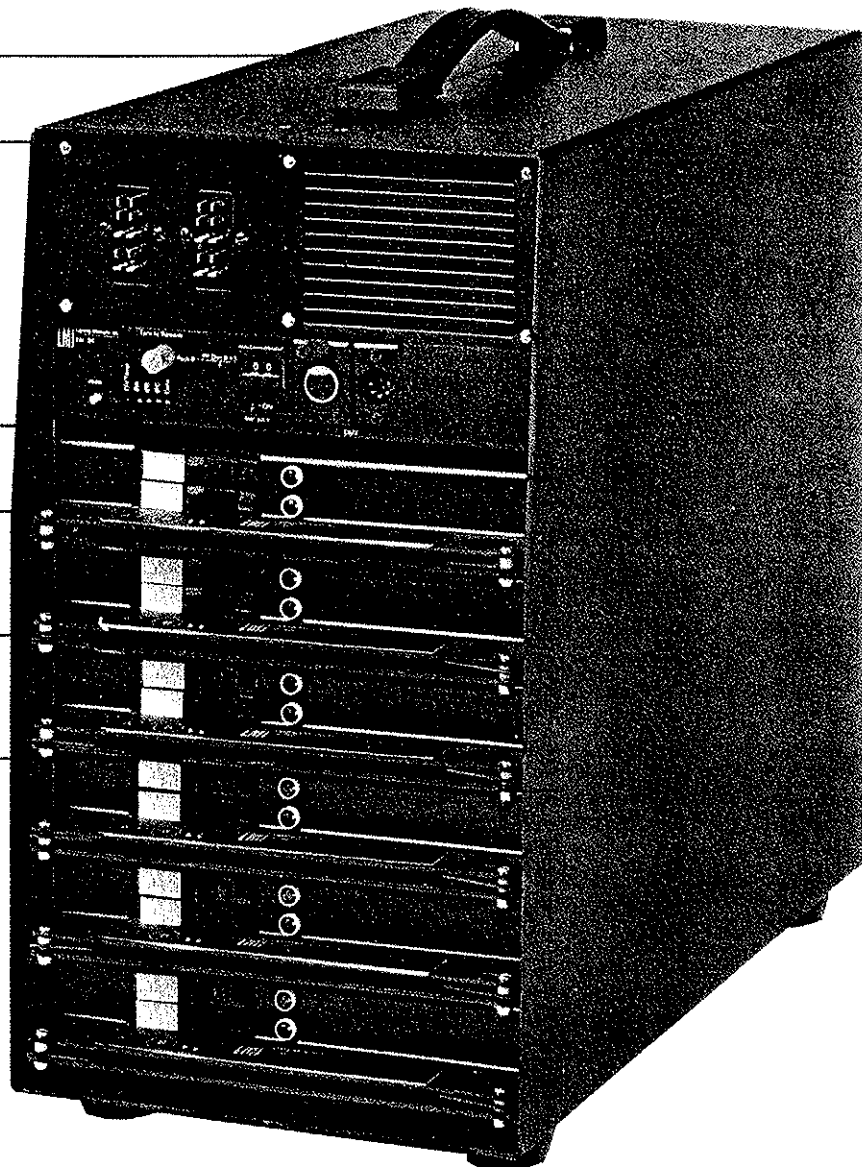

L86-DIMMER PACKS

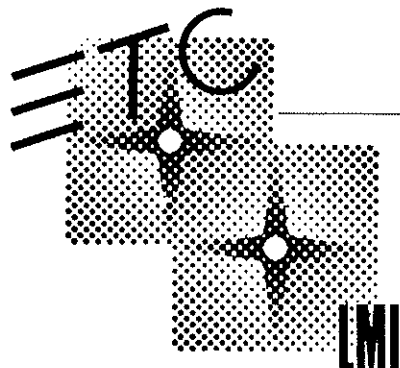

ETC/LMI

3030 Laura Lane
Middleton, WI 53562
608/831-4116
608/836-1736 (FAX)

L86-DIMMER PACKS

ANALOG CONNECTORS
16 PIN CINCH-JONES STANDARD
1 PER 6 DIMMERS

FILTERED COOLING AIR ENTRY

L86/EM24 ELECTRONICS MODULE

CONNECTORS FOR DMX-512 AND AMX-192

THUMBWHEEL FOR DIMMER DIGITAL ADDRESS

PLUG IN MODULES
QUAD [4] -10A
DUAL [2] -20A
SINGLE -50A
DOUBLE -100A

AIRFLOW EXIT

LOAD INDICATOR

SIGNAL INDICATOR

SIGNAL BUMP [TEST] BUTTON

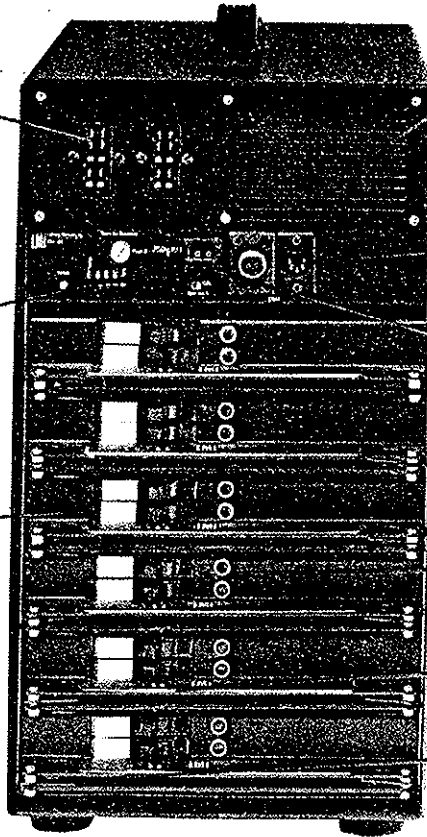

Typical Multiplex Hookup

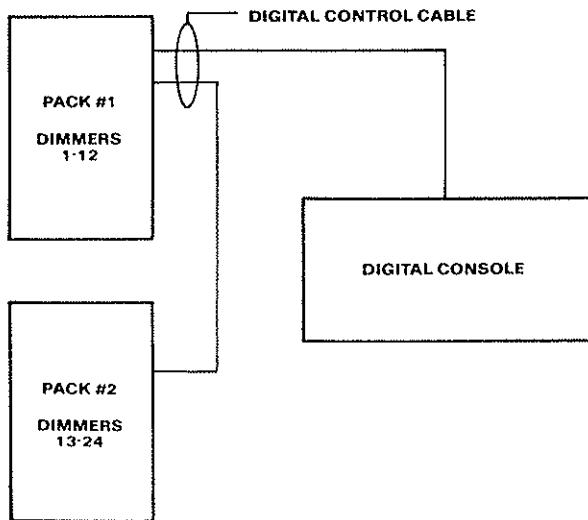

Typical Analog Hookup

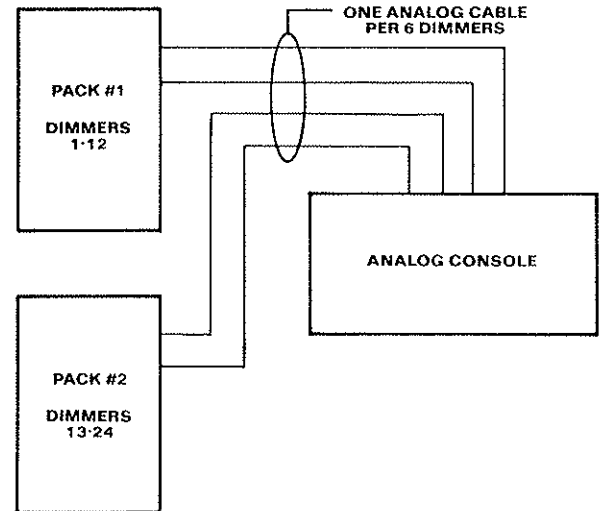

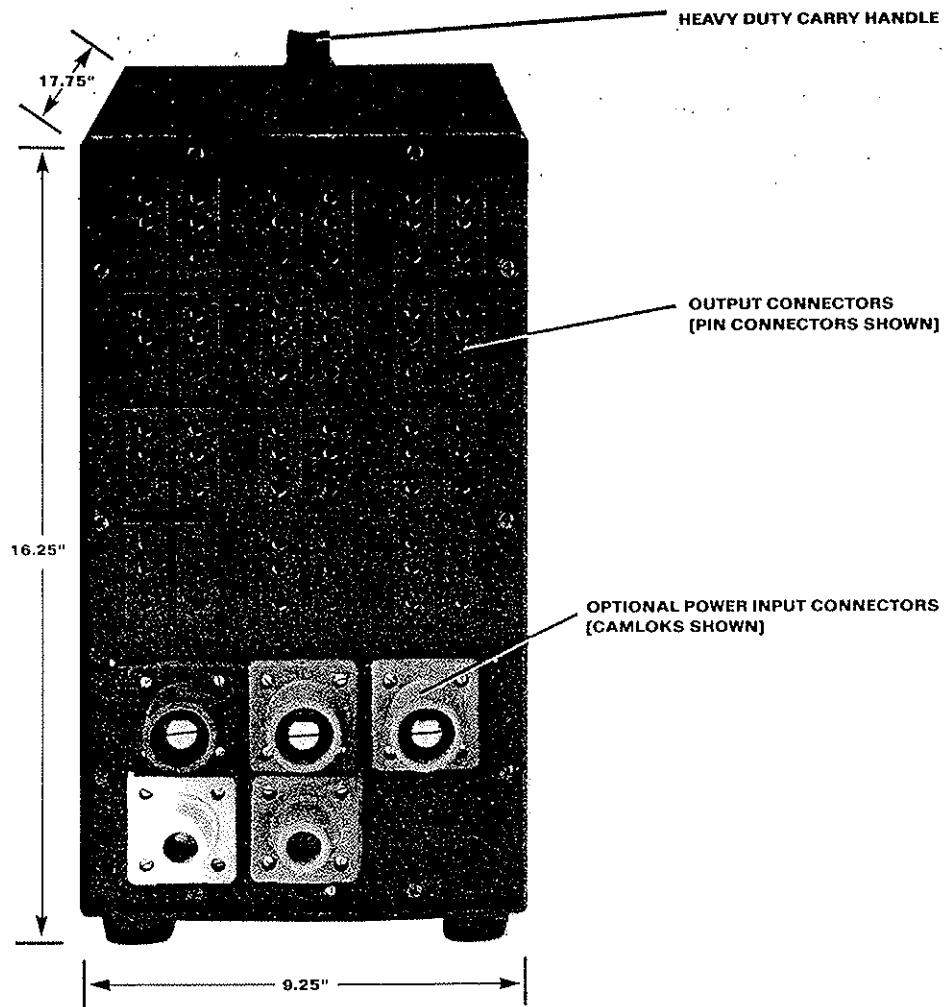

Specifications

Catalog #	Description
L86/2410A	24-10A dimmers with 1-"U" ground per dimmer
L86/2410B	24-10A dimmers with 1-pin connector per dimmer
L86/2410X	24-10A dimmers with terminals and blank panel
L86/1220A	12-20A dimmers with 2-"U" ground per dimmer
L86/1220B	12-20A dimmers with 2-pin connectors per dimmer
L86/1220C	12-20A dimmers with 1-GTL connector per dimmer
L86/1220X	12-20A dimmers with terminals and blank panel
L86/650B	6-50A dimmers with 1-pin connector per dimmer
L86/650C	6-50A dimmers with 1-twistlock per dimmer
L86/650X	6-50A dimmers with terminals and blank panel
L86/3100B	3-100A dimmers with 1-pin connector per dimmer
L86/3100X	3-100A dimmers with terminals and blank panel

Specifications

General: L86 dimmer packs provide reliable control of incandescent loads from 10W to the rated capacity of the dimmer. Packs offer a complete range of dimmer sizes and operate on most common control formats.

Physical: L86 dimmer packs are fabricated of .100 aluminum and .060 steel. All parts shall be properly primed and finished with black baked textured enamel. Graphics shall be silkscreened in gold epoxy ink.

Pack dimensions shall be 9.25W x 16.25H x 17.75D. Weight with 6-dual 2.4Kw modules is 90#. Front and rear control, power and load connection surfaces shall be recessed into the pack for component protection. Pack shall be provided with a rubber padded spring steel handle for portability.

Electrical: L86 series dimmer packs operate on either 3 phase 4 wire + ground, 120/208v, 60Hz A.C. or 1 phase 3 wire + ground, 120/240v, 60Hz A.C. at an amperage sufficient to power the pack. Packs for operation on other power grids are available.

Pack and module power ratings are as follows:

Model #	Dimmers	Power	
L86/2410	24x10A	80A 3ph	120A 1ph
L86/1220	12x20A	80A 3ph	120A 1ph
L86/650	6x50A	100A 3ph	150A 1ph
L86/3100	3x100A	100A 3ph	N/A

The power feed block shall be designed for easy conversion from three phase to single phase power. Electronics shall have a switch to select phasing proper for the power supplied to the pack.

Packs shall be supplied standard with lugs for power input. Non-UL listed available options include cam-locks or appropriately rated multi-pin connectors.

Dimmer modules shall plug in and contain all power components. Available modules include:

Model #	Description
L86/1200	4 x 10A
L86/1200I	4 x 10A with indicators
L86/2400	2 x 20A
L86/2400I	2 x 20A with indicators
L86/6000	1 x 50A
L86/6000I	1 x 50A with indicators
L86/12000	1 x 100A
L86/12000I	1 x 100A with indicators

Standard pack has modules with indicators. Additional specifications on individual dimmer modules is available on the module data sheet.

Output connectors are available in the following configurations. Figures are the number of outlets per dimmer, ordering suffix is in parenthesis.

Model #	Blank	Pin	Edison	Twist
L86/2410	(X)	1 (B)	1 (A)	N/A
L86/1220	(X)	2 (B)	2 (A)	1 (C)
L86/650	(X)	1 (B)	N/A	1 (C)
L86/3100	(X)	1 (B)	N/A	N/A

Custom output panels with other connector configurations are available.

L86/EM24 Electronics: The L86/EM24 electronics modules shall receive control data in the following formats:

- 0-10vdc analog
- USITT standard DMX-512
- Colortran
- USITT standard AMX-192
- Micro II

Dimmer electronics shall accept digital and analog control signals simultaneously with the dimmer outputting the highest level. Only one multiplexed format can be accepted at a time.

Electronics modules shall be supplied with the following indicators and controls:

- Control reset pushbutton
- A.C. line indicators
- Over temperature indicator
- Valid data indicator
- Pack address selector switches
- Last pack terminator switch
- Multiplex data in and out connectors
(analog control connectors located on pack)

Pack address selector switches shall set dimmer address numbers and enable diagnostic routines. Dimmer packs are addressed in multiples of 6 and it shall not be necessary to skip dimmer numbers to compensate for pack size except for 3 x 100A packs.

DMX-512 update speed shall be 40Hz. Response to control shall be less than 60 milliseconds. Output curve shall be IES square law.

Any two dimmers, regardless of phasing, with identical loads shall track within 2vac RMS throughout the entire curve.

Electronics shall have user operable diagnostics to assist in troubleshooting if required. They shall also have a diagnostic start up routine. This routine shall check program ROM and EROM for errors. Pack will not energize with errors.

Electronics shall be protected by a 1A slo-blo fuse with an interrupt rating of 10,000A.

Thermal: Dimmer packs shall contain a continuous duty, sealed bearing low noise fan to maintain the temperature of all components at proper operating levels with all dimmers under full load provided the ambient temperature does not exceed 40° C (104° F). The air intake port shall be equipped with a filter to clean incoming air. Packs that do not filter forced air are not acceptable. The air path shall be arranged so that each dimmer module receives fresh air. Dimmer packs that pass cooling air over the heat generating components of more than one dimmer are not acceptable. The fan shall be operational at any time the pack is receiving power.

Dimmer pack shall contain a thermostat to signal the operator that safe operating temperatures have been exceeded.

Electronics shall automatically signal an overheat condition by blinking the overtemp indicator. Dimmer modules are individually protected and will shut down when safe operating temperatures are exceeded.

Performance: Each dimmer channel shall smoothly control loads from 10w to the rated load of the dimmer.

Each dimmer shall be capable of operating indefinitely at its rated capacity.

Dimmer pack shall be factory tested and all printed circuit board assemblies burned in at elevated temperatures for a minimum of 4 hours.

Approvals: Dimmer pack shall be Underwriters Laboratory listed with an interrupt rating of 10,000A and be so labeled pending UL tests.

Dimmer modules shall be Underwriters Laboratory recognized components and be so labeled pending UL tests.

All specifications and designs subject to change without notice.